

AGROSAL d.o.o.



LOMBARDINI
A KOHLERCOMPANY

9LD



AGROSAL d.o.o.

Gregorčičeva ulica 38, 5270 Ajdovščina
telefon: 05 368 90 96, fax: 05 368 90 97
e-mail: info@agrosal.si, www.agrosal.si

GASKET/RING SET

POS.	CODE	DESCRIPTION	Qty
1	<----->	GASKET SET - see Pos. N 1a	0
1a	8205.097	RING AND GASKET COMPLETE SET	1
1b	8185.018	EMERY GASKET SET	1
2	8150.010	O RING SET	1

N
8LD

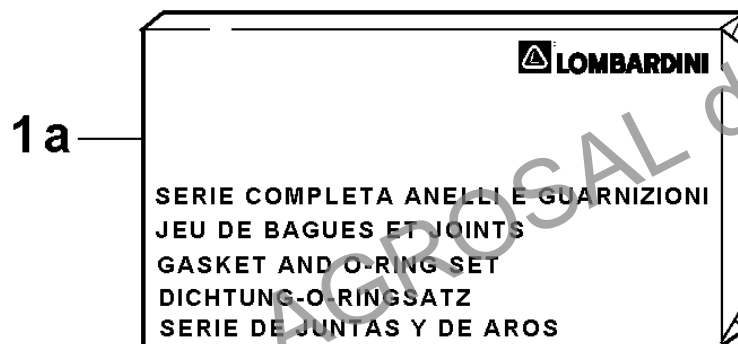
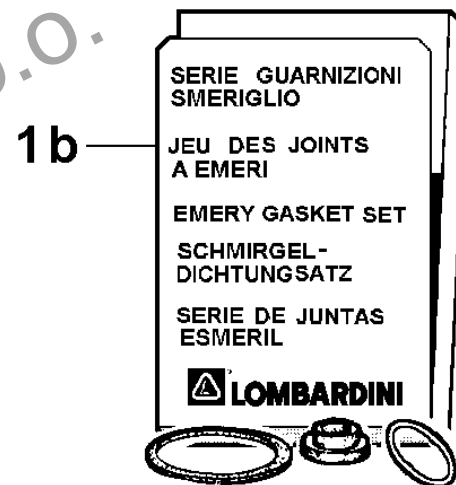
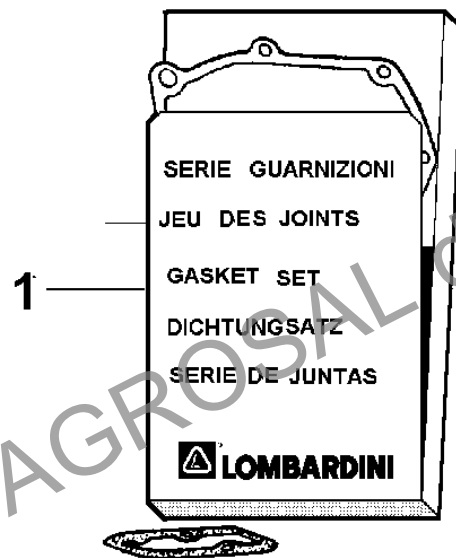

**LOMBARDINI**

A KOHLER COMPANY

Group: 9LD

Engine: 9LD 561-2 Drawing: A

INTAKE AND EXHAUST

POS.	CODE	DESCRIPTION	Qty
1	2605.034	air cleaner cover	1
1	3700.133	DRY AIRCLEANER	1
3	2175.048	air cleaner cartridge	1
4	1261.067	seal ring	1
5	8965.001	plug M 10	1
6	4670.059	copper gasket diam.10	1
7	8741.015	support	1
9	3240.018	nut M 8	1
10	9170.052	muffler end (diam. 39,5/42)	1
11	9895.067	knob	1
12	4480.005	gasket	1
13	8345.061	cloging indicator	1
14	7330.270	union M 10X1,5	1
15	5460.293	muffler (flywheel side exhausting)	1
16	6780.084	stud M 8 X 40 (52)	2
17	6927.172	muffler guard	1
18	3240.163	nut M 8	4
19	2486.028	exhaust manifold	1
19	2486.067	exhaust manifold	1
20	7565.007	washer diam. 8	1
21	1770.005	bolt M 8 X 1,25 X 22	1
24	2136.053	filter cap (5'' air cleaner)	1
25	9346.019	rubber hose	1
26	2175.124	main cartridge 5''	1
27	1240.005	snap ring	1
28	6780.045	stud M 8 X 12 (24)	1
29	2175.125	safety cartridge 5''	1
30	6780.086	stud M 8 X 65 (77)	2
31	4420.019	exhaust manif.gasket	2
32	4500.079	exhaust gasket	1
33	3815.013	exh.flange h=7,5	1
34	6780.005	stud M 8 X 18 (30)	2
36	3240.163	nut M 8	2
37	9170.028	muffler end (d.46,5/40)	1
37	9170.050	muffler end (d.43,5/42)	1
38	6491.031	discharging elbow	1
41	2100.055	preheating glow plug 12V M 22 X 1,5)	1
41	2100.056	preheating glow plug 24V	1
42	6902.027	manifold flange	2
43	2486.037	exh.manifold two outlets	1
44	4500.079	exhaust gasket	1
45	6300.018	plate	1
46	5461.047	exhaust.muffler	1
47	5460.237	muffler spec.Ferrari	1
47	5460.248	muffler	1
48	8545.566	support diam 153 for air cleaner 5''	1
49	6727.022	cyclonic prefilter	1
50	3617.223	clamp	1
51	3700.455	dry air cleaner (5'') with safety cartridge	1
51	3700.456	dry air cleaner 5''	1
52	4776.062	gasket	2
53	6780.049	intake stud M 8 X 20 (36)	1
55	8965.065	drilled plug M 22	1

Group: 9LD
Engine: 9LD 561-2 Drawing: A

INTAKE AND EXHAUST

POS.	CODE	DESCRIPTION	Qty
56	6780.030	stud M 8 X 70 (82)	2
57	2486.031	eXhaust manifold	1
58	«-----»	washer diam. 8 - no more fitted	0
59	2940.087	eXhausting elbow	1
60	4500.079	eXhaust gasket	1
61	«-----»	see Pos. A 62	0
62	2751.046	MUFFLER COVER	1
63a	3700.320	air cleaner	1
64	5496.110	upper filter.element	1
65	3525.080	spacer	1
66	3240.164	nut M 8	3
67	«-----»	washer diam. 8 - no more fitted	0
68	1770.039	bolt M 8 X 1,25 X 28	2
69a	2486.311	inlet manifold	1
69a	2486.312	inlet manifold	1
70	3240.164	nut M 8	4
71	8965.071	plug M 22	1
72	3630.023	clamp	1
73	2145.013	cap	1
74	2941.097	eXhausting elbow	1
75	9400.091	suction line mm 380X8X10	1
75	949R.054	suction line mm 250X8X10	1
76	4420.020	inlet manifold gasket	2
77	3527.255	spacer for inlet manifold	2
78	6780.084	stud M 8 X 40 (52)	2
79	4776.032	gasket h= 7 diam. 154	1
80	5496.075	filtering element	1
81	2486.396	inlet manifold two inlets	1
83	4115.048	hook	2
84	3781.027	flange h= 7 mm d=40 mm	1
86	7300.091	breather union	1
86	7301.194	breather union	1
86a	7301.111	breather union	1
87	5461.003	eXhaust muffler	1
88	5460.231	eXh.muffler	1
90	4889.015	breather cap	1
91	4670.014	copper gasket diam.12	1
91a	4670.061	copper gasket diam.14	1
91b	4670.027	copper gasket	1
93	5460.232	eXh.muffler	1
93	5460.291	muffler with horiz.inlet flange	1
94	6927.128	muffler guard	1
97	3630.178	clamp	1
98	1770.001	bolt M 8 X 1,25 X 12	3
99	7565.007	washer diam. 8	3
100	7625.010	washer diam. 8	3

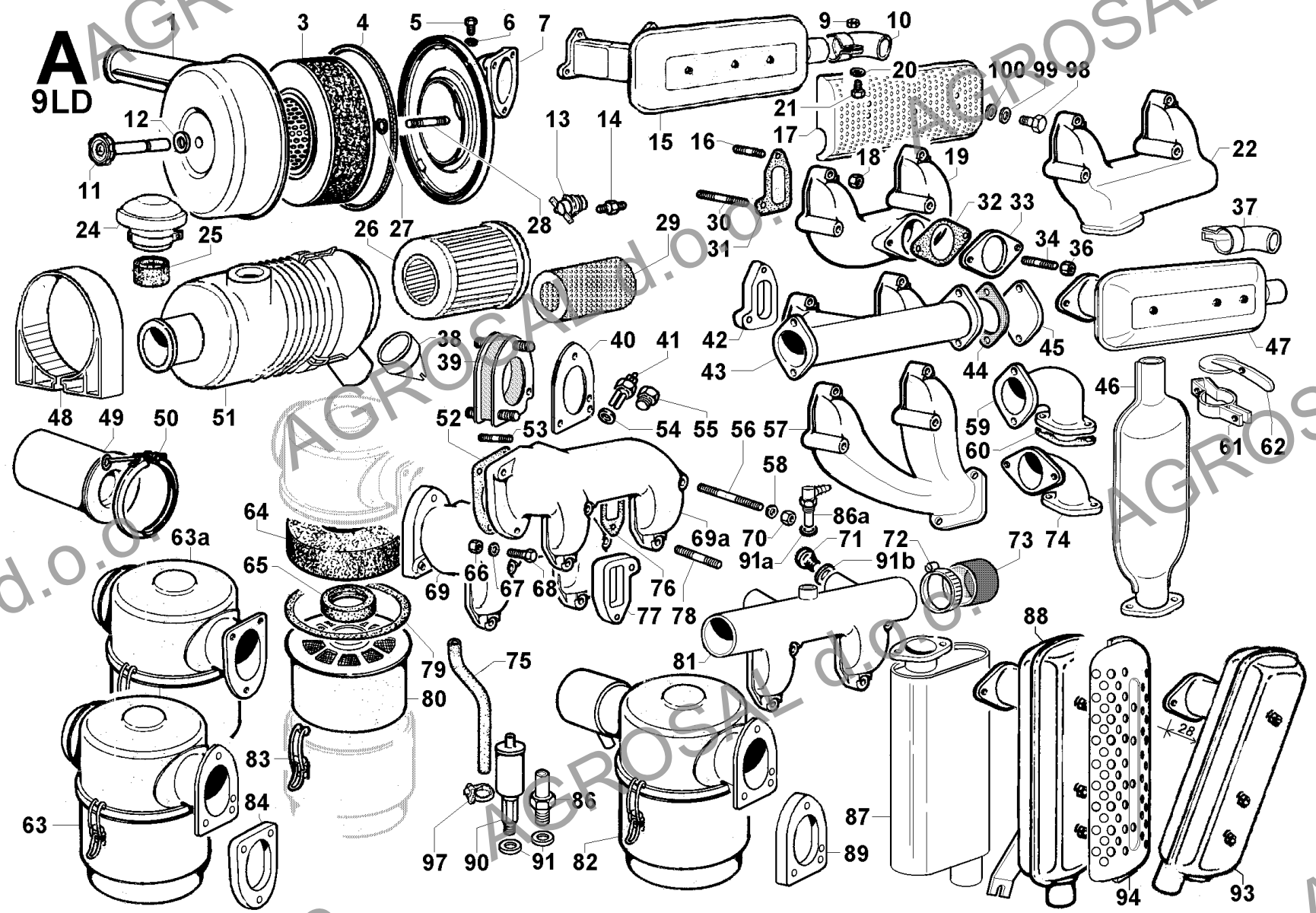

**LOMBARDINI**

A KOHLER COMPANY

Group: 9LD

Engine: 9LD 561-2 Drawing: B

CONN.ROD/PISTON/CYLINDER/CRANKSHAFT/FLYWHEEL/CRANKCASE/FLANGING/MOUNTS

POS.	CODE	DESCRIPTION	Qty
1	6500.109	PISTON SET std	2
1	6500.110	PISTON SET +0,50	2
1	6500.111	PISTON SET +1,00	2
2	8211.206	piston ring set std.	2
2	8211.207	piston ring set +0,50	2
2	8211.208	ring set +1,00	2
3	1240.022	snap ring	4
4	8480.029	gudgeon pin	2
5	1630.014	small end bearing	2
6	1526.111	CONNECTING ROD	2
7	1640.059	big end bushing std.	2
7	1640.060	big end bushing -0,25	2
7	1640.061	big end bushing -0,50	2
8	1050.785	CRANKSHAFT	1
9	2280.056	crankshaft wooddruff key	1
10	4701.040	bearing housing gasket 0,25	1
10	4701.049	bearing housing gasket 0,40	1
11	1611.160	bearing std. (Flywheel side)	1
11	1611.161	bearing -0,25 (Flywheel side)	1
11	1611.162	bearing -0,50 (flywheel side)	1
12	1770.150	bolt M 8 X 1,25 X 22	8
13	8675.290	bearing housing (rear)	1
14	2280.069	key 5/8''X 7/16''X 110	1
14	2280.093	key 3/8''X 3/8''	1
15	1110.088	parallel eXtension 2''	1
15	1111.040	parallel eXtension (1''1/2)	1
16	6429.148	engine mount (starting motor side)	1
17	6850.103	cyl.head stud	8
18	2380.570	cylinder	2
18a	4898.044	kit cylinder-piston set-emery gasket set	2
19	1511.111	CRANKCASE	1
20	«-----»	washer	0
21	1770.109	conn.rod bolt M 8 X 50	4
22	4670.058	copper gasket diam. 8,2X12X1,5	2
23	8965.034	plug M 8	2
24	4936.042	crankshaft gear	1
25	8675.266	gear side support std	1
25	8675.267	gear side support -0,25	1
25	8675.268	gear side support -0,50	1
26	2280.056	crankshaft wooddruff key	1
27	9080.133	cap diam. 8	4
28	1213.318	oil seal (rear) 50X70X10	1
29	5168.054	front cover backing plate	1
30	1760.001	bolt M 6 X 1 X 10	2
31	9080.083	plug	1
32	9865.258	screw M 16 X 1,5 left rotation	1
33	7626.033	washer	1
34	1770.156	bolt M 8 X 1,25 X 25	2
35	«-----»	washer	0
37	8676.057	MAIN BEARING HOUSING	1
38	1610.082	main bearing shell c. std.	1
38	1610.098	main bearing shell c. -0,25	1
38	1610.099	main bearing shell c. -0,50	1

Group: 9LD

Engine: 9LD 561-2 Drawing: B

CONN.ROD/PISTON/CYLINDER/CRANKSHAFT/FLYWHEEL/CRANKCASE/FLANGING/MOUNTS

POS.	CODE	DESCRIPTION	Qty
39	2816.025	crown gear	1
40	1861.045	bolt Es.50 l=52 d= -	1
40	1861.056	bolt Es.50 l=59 d=35	1
40	1861.057	bolt Es.50 l=60 d=40	1
40	1861.076	bolt Es.50 l=66 d=35	1
41	5111.005	safety plate	1
42	9880.104	FLYWHEEL with CROWN	1
42	9880.109	FLYWHEEL with CROWN	1
42	9880.122	FLYWHEEL with CROWN	1
42	9880.940	FLYWHEEL with CROWN	1
42	9884.086	FLYWHELL with CROWN	1
42	9885.072	FLYWHELL with CROWN	1
42	9885.097	FLYWHELL with CROWN	1
43	7565.011	washer diam.10	16
44	1780.007	bolt M 10 X 1,5 X 35	16
45	«-----»	stud	0
46	9730.034	screw M 8 X 55	2
47	5111.069	safety plate	1
48	1862.144	bolt	1
49	1213.321	oil seal (front) 42X58X10	1
50	8900.463	FRONT COVER	1
51	9732.063	screw M 8 X 35	11
52	9732.077	screw M 8 X 70	3
53	8460.055	locating dowel	2
55	4701.039	gasket	1
56	2751.096	auxiliary housing	1
57	6429.033	engine mount	4
58	2751.095	blanking plate	1
59	1201.027	rubber oil seal	1
60	4776.087	auxiliary hous.gasket	1
61	7625.010	washer diam. 8	3
62	3240.018	nut M 8	3
63	9730.032	screw M 8 X 45	3
64	4936.061	gear	1
65	6429.147	engine mount (control side)	1
66	8430.054	lockpin 7 X 16	2

B
9LD

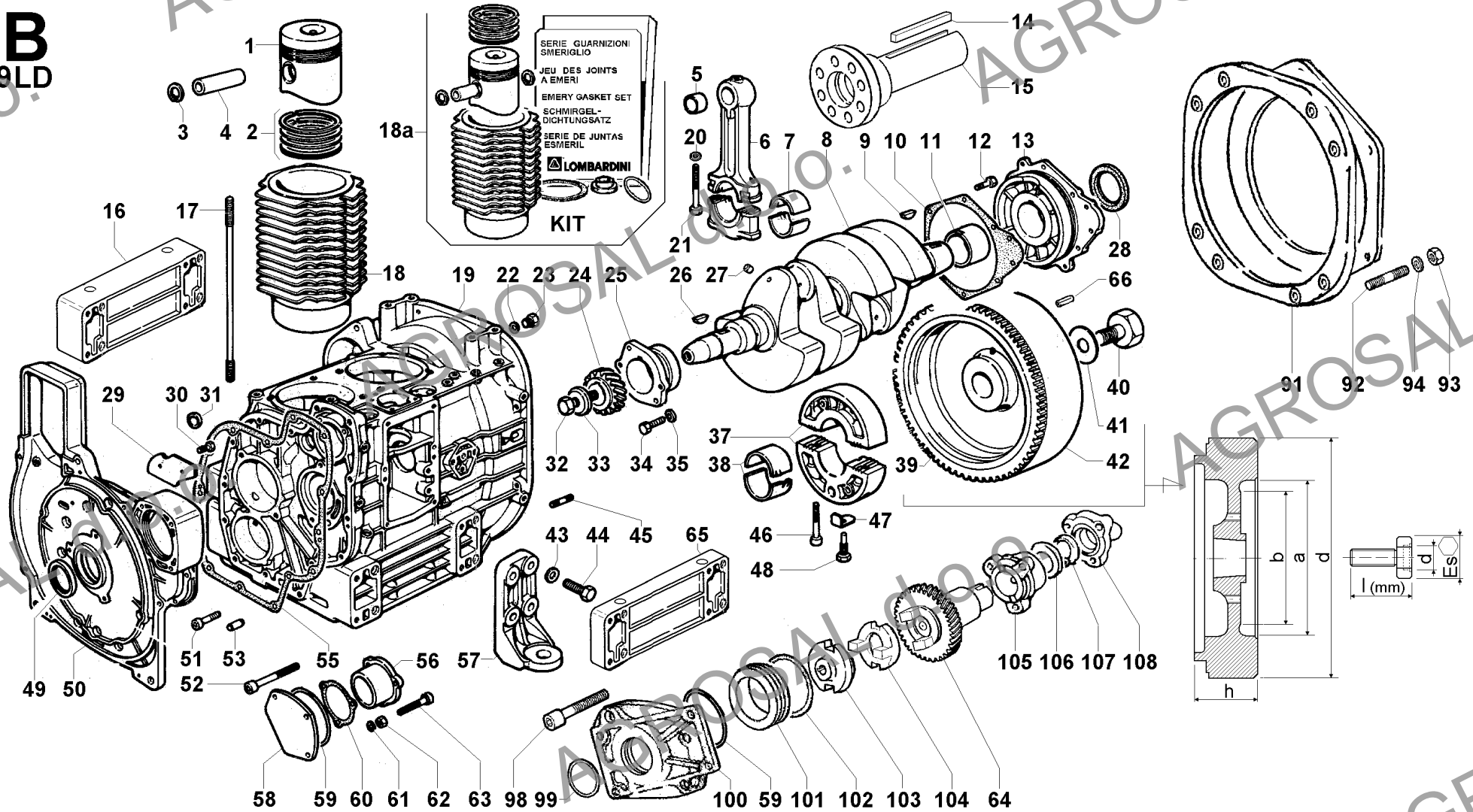

**LOMBARDINI**

A KOHLER COMPANY

Group: 9LD

Engine: 9LD 561-2 Drawing: D

CONTROLS/LUBRICATING SYSTEM

POS.	CODE	DESCRIPTION	Qty
1	<----->	oil cartridge cap with M 14 hole - see notes	0
4a	9680.058	pressure oil valve	1
5	<----->	spring - see notes	0
7	2516.061	REMOTE ACCELER.CONTROL-HAND STOP	1
7	2516.094	REMOTE ACCEL.CONTROL-WITHOUT STOP	1
7	2516.109	REMOTE ACCELER.CONTROL-HAND STOP	1
7	2516.114	REMOTE ACCELER.AND STOP CONTROL	1
8	3240.019	nut M 8 alpha brass	2
9	9180.192	cable end	2
11	2381.015	TORQUE CONTROL	1
11	8576.006	EXTRA FUEL DEVICE	1
12	6780.089	stud M 8 X 28 (45)	1
13	3240.018	nut M 8	1
14	3240.008	nut M 6	1
15	1760.041	bolt M 6 X 1 X 40	1
16	3240.008	nut M 6	1
17	1760.041	bolt M 6 X 1 X 40	1
18	4670.058	copper gasket diam. 8,2X12X1,5	1
19	5830.119	nut	2
20	9790.023	screw M 5 X 7	2
21	5200.108	cable adapter plate	1
22	3240.164	nut M 8	1
23	5200.323	control lever	1
24	<----->	O ring 137 - see notes	0
29	9455.131	lub.oil pipe	2
30	1400.387	eXtended dipstick (mm 110)	1
31	1400.438	dipstick (mm 145)	1
31	1400.515	dipstick std (mm 110)	1
32	7555.004	washer diam. 6	1
33	<----->	pin	0
33	6040.015	pin	1
38	5168.052	tabwasher	1
39	3240.131	nut	1
40	3240.058	nut	1
42	4775.526	gov. housing gasket	1
43	9730.018	screw M 6 X 45	1
44	<----->	screw	0
46	1770.042	bolt M 8 X 1,25 X 10	1
47	5200.108	cable adapter plate	1
48	3240.164	nut M 8	1
49	5200.108	cable adapter plate	1
50	3240.164	nut M 8	1
51	<----->	cap	0
52	3240.164	nut M 8	1
53	1240.077	snap ring	1
54	7625.098	washer diam. 8,4	1
55	6545.009	knob	1
56	4340.067	jacket	1
57	<----->	head filter oil conn. - see notes	0
57a	7265.021	oil filter connector	1
57b	7330.343	oil filter connector	1
58	<----->	oil filter cartridge - see notes	0
58	2175.060	oil filter cartridge for low temperature	1

Group: 9LD
Engine: 9LD 561-2 Drawing: D

CONTROLS/LUBRICATING SYSTEM

POS.	CODE	DESCRIPTION	Qty
58a	2175.107	oil filter cartridge (mm 59)	1
58a	2175.131	oil filter cartridge (mm 90)	1
59	«-----»	oil filter cover - see notes	0
61	3240.036	nut M 10	1
62	7565.011	washer diam.10	1
63	4936.009	oil pump drive gear	1
64	6605.037	lub.oil pump ass.y	1
65	«-----»	key	0
66	9330.033	dipstick guard	1
67	7625.012	washer diam. 8,4	1
68	9732.074	screw M 8 X 20	1
69	1165.010	circlip	1
70	3240.008	nut M 6	1
71	7555.004	washer diam. 6	1
72	5200.760	operating arm	1
73	«-----»	support pin - see Pos. F 72	0
74	2690.287	HAND CONTROL	1
75	«-----»	sleeve	0
77	8460.055	locating dowel	2
78	1200.034	O ring 105	1
79	9732.078	screw M 6 X 25	5
80	5680.077	spring	1
81	6870.021	stud	1
82	5200.110	lever	1
83	1200.034	O ring 105	1
84	5680.077	spring	1
85	1241.009	circlip diam. 19	1
86	«-----»	spring	0
89	5200.154	pivot arm	1
90	1770.009	bolt M 8 X 1,25 X 35	2
91	7565.007	washer diam. 8	2
93	1200.001	O ring 108	1
95	5090.010	oil strainer	1
96	7565.004	washer diam. 6	1
97	1400.094	dipstick (mm 520)	1
98	7625.106	washer diam. 7,1	2
99	9761.043	screw M 6 X 10	1
100	6140.370	pin	1
101	5200.587	governor push rod actuator	1
102	3527.246	spacer	1
103	5550.026	eXtra fuel spring	1
103	5801.180	eXtra fuel spring (compressor version)	1
104	1241.009	circlip diam. 19	1
105	3000.004	ball bearing	2
107	1200.034	O ring 105	1
108	1241.009	circlip diam. 19	1
109	1200.034	O ring 105	1
110	«-----»	spacer	0
112	5680.077	spring	1
113	9245.135	tie rod	1
114	9730.024	screw M 8 X 16	2
115	6370.281	plate	1
116	5200.583	lever	1

Group: 9LD
Engine: 9LD 561-2 Drawing: D

CONTROLS/LUBRICATING SYSTEM

POS.	CODE	DESCRIPTION	Qty
117	5680.077	spring	1
118	5200.154	pivot arm	1
119	8430.065	locking needle	1
120	7555.029	washer diam. 8	14
121	1770.155	bolt M 8 X 1,25 X 30	14
121	9732.063	screw M 8 X 35	14
122	9080.182	plug diam.10	1
123	6645.619	OIL PAN high capacity 5 liters	1
123	6645.639	OIL PAN 3 oil drain plugs	1
123	6645.640	OIL PAN (side discharging)	1
124	4670.016	copper gasket diam.14	1
125	8965.005	oil drain plug M 14	1
126	4601.177	sump gasket	1
127	5200.585	lever	1
128	8785.103	actuating arm	1
129	5655.349	spring	1
130	1541.106	balance lever	1
131	5655.349	spring	1
132	1165.005	circlip diam. 6	1
133	7625.010	washer diam. 8	1
134	9730.031	screw M 8 X 40	2
135	7748.031	washer	2
136	4775.421	gasket	2
137	7625.012	washer diam. 8,4	2
138	3240.018	nut M 8	2
139	7350.051	oil cooler	1
140	9485.176	oil pipe mm 175	1
141	«-----»	oil line - see notes	0
141a	9485.281	oil line	1
142	5953.036	nipple	3
143	4670.019	copper gasket diam.16	3
144	«-----»	spacer - see notes	0
144a	3902.353	oil flange	1
145	1901.155	union bolt M 14	1
146	4670.061	copper gasket diam.14	2
147	1202.036	O ring	1
148	5151.075	plate	1

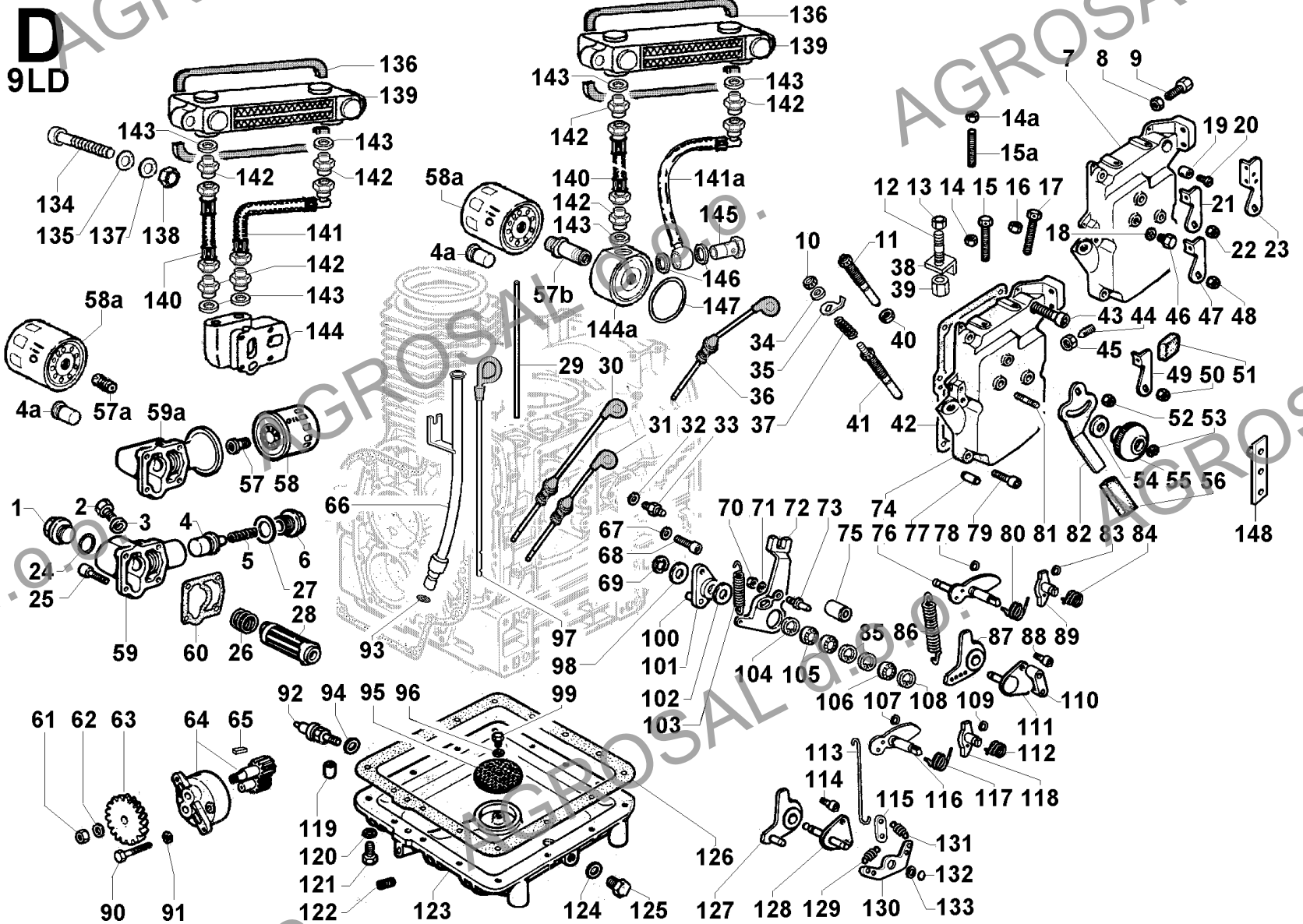

**LOMBARDINI**

A KOHLER COMPANY

Group: 9LD

Engine: 9LD 561-2 Drawing: F

COOLING SYSTEM/STARTING

POS.	CODE	DESCRIPTION	Qty
1	2920.106	denoised hood	1
1a	2920.124	denoised hood	1
2	8725.095	alternator supp.	1
3	«-----»	stay bolt	0
3a	9730.434	screw M 10 X 120	1
4	2280.045	tab	1
5	1157.262	eXternal volt.alternator 12V-33A	1
6	6927.635	alternator guard	1
8	«-----»	dashboard	0
10	8506.026	angle bracket	1
11	«-----»	lampe-socket	0
12	9195.104	head temperatur thermostat	1
13	1780.003	bolt M 10 X 1,5 X 18	1
14	7565.011	washer diam.10	1
15	7245.417	dashboard 3 warning lights	1
15a	7245.418	dashboard 6 warning lights	1
16	4062.233	fuse 50 A	1
16	4062.238	fuse 100 A (for two preheating glow plugs)	1
17	3300.227	elongated nut	1
18	4776.091	duct seal	1
19	8546.265	bracket	1
20	«-----»	see Pos. F 5	0
21	7100.063	pulley for alternator	1
22	2440.308	belt mm 850	1
23	9790.039	screw M 6 X 12	4
24	4776.093	duct seal rear	1
25	5450.009	oil manometer	1
26	5175.162	lamp 12V	2
27	7625.070	washer diam. 6	2
28	1760.003	bolt M 6 X 1 X 12	2
29	5041.020	key switch	1
30	6491.005	pipe elbow	1
31	5840.224	starting motor 12V 1,7KW	1
32	9730.046	screw M 10 X 35	1
33	1770.002	bolt M 8 X 1,25 X 16	1
34	7565.007	washer diam. 8	1
35	3617.045	clamp	1
36	2569.165	denoised cowling	1
36	2569.224	shroud without denoised panel fitting	1
37	6927.055	guard	1
38	3240.066	nut M 10	2
39	7565.011	washer diam.10	2
40	6491.013	pipe elbow	1
41	6745.050	oil switch 0,3 bar (M 12)	1
42	6800.004	stud M 10 X 20 (35)	1
43	4776.092	duct seal front	1
44	4670.060	copper gasket diam.12	1
45	9790.039	screw M 6 X 12	2
47	5066.083	denoised duct	1
48	3350.077	deflector	1
49	5066.078	denoised duct	1
50	3617.102	cable saddle	1
50a	3617.021	clamp	1

COOLING SYSTEM/STARTING

POS.	CODE	DESCRIPTION	Qty
51	9731.092	screw M 8 X 14	1
52	9730.008	screw M 6 X 10	1
53	9718.252	blower	1
54	4893.022	FAN ASS.Y	1
55	2471.014	collar	1
56	1157.154	volt.alternator 12V 14A - 3 wires	1
56	1157.167	volt.alternator 12V 16A - 2 wires	1
56	1157.227	volt.alternator 24V 6A - 3 wires	1
57	5455.006	hand-crank	1
58	3203.050	selflocking nut M 6	1
59	2670.049	pulley cover	1
60	1760.094	bolt M 6 X 1 X 100	1
61	8965.031	grease plug	1
62	1202.016	O ring 109	1
63	8430.019	lockpin	1
64	9865.122	screw M 6 X 12	4
65	6480.040	pinion	1
66	9245.081	stay bolt	1
67	8836.094	support	1
68	1970.094	sleeve	2
69	9731.022	screw M 5 X 20	4
70	7555.004	washer diam. 6	3
71	1240.041	circlip	1
72	7980.045	cup	1
73	5801.028	spring	1
74	7885.019	gear housing	1
75	1585.058	ball bearing	1
77	8795.016	support	1
78	4970.014	gear	1
79	9731.077	screw M 8 X 85	4
80	1780.006	bolt M 10 X 1,5 X 30	4
80	9730.044	screw M 10 X 25	4
81	7565.011	washer diam.10	4
82	6961.059	start pulley	1
82	6975.098	pulley for eXt.alternator	1
83	1760.006	bolt M 6 X 1 X 20	5
84	7625.008	washer diam. 6,4	5
85	9732.078	screw M 6 X 25	5
86	2145.014	regulator cap	1
87	6740.153	inlet regul.Saprisa	1
87	6740.154	inlet regul.Ducati	1
88	7362.228	voltage regulator. 12V 14/26A-6 contacts for alternator 3 wires	1
88	7362.229	voltage regulator. 24V 26A - 6 contacts for alternator 3 wire	1
88	7362.294	volt.regulator 12V 21A fitted for electronic tachometer - 6+W c	1
88	7362.298	voltage regul.12 V maX 30 A - 5 contacts for alt.2 wires	1
88	7362.314	volt.regulator 12V 30A fitted for electronic tachometer - 5+W c	1
89	9732.092	screw M 8 X 18	2
90	4935.061	gear	1
91	8780.015	gear support	1
92	1213.173	seal ring 20X35X7	1
93	8903.102	ANGLE GEAR SUPPORT	1
94	7475.018	angle gear	1
97	5096.040	guard	1

COOLING SYSTEM/STARTING

POS.	CODE	DESCRIPTION	Qty
98	4505.037	gasket	1
99	6275.102	spring plate	1
100	4775.525	auxiliary hous.gasket	1
101	2185.882	extension wire	1
101	2185.893	extension wire	1
102	2185.873	wiring harness for dashboard 6 warning lights	1
102	2185.891	wiring harness for dashboard 3 warning lights	1
103	9730.325	screw M 5 X 10	4
107	8506.118	dashb.suppl.	1
115	1780.003	bolt M 10 X 1,5 X 18	4
116	«-----»	nut M 10	0
117a	7565.011	washer diam.10	1
118	«-----»	washer diam. 8	0
119a	3203.060	nut M 10	1

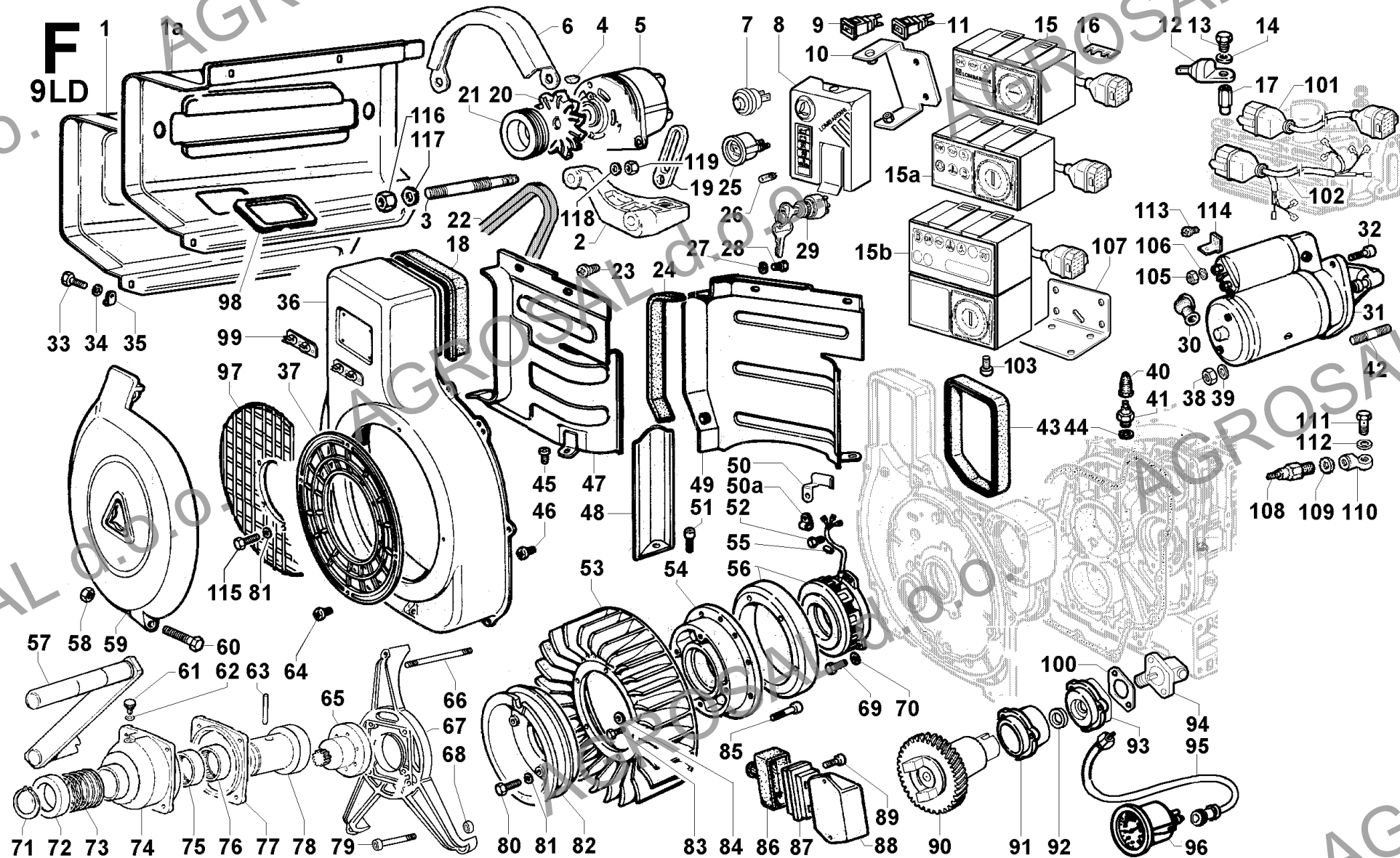

**LOMBARDINI**

A KOHLER COMPANY

Group: 9LD

Engine: 9LD 561-2 Drawing: C

CYLINDER HEAD/ROCKER ARM BOX/VALVES/TIMING/SPEED GOVERNOR

POS.	CODE	DESCRIPTION	Qty
1	8506.003	engine lifting eye	2
2	9732.075	screw M 8 X 50	4
3	9032.079	FILLER OIL CAP M 36X3	1
4	1200.015	O ring 137 for filler oil cap	1
5	2125.338	rocker arm cover with hole for oil filler	1
6	2125.758	ROCKER COVER FRONT (with oil filler hole)	1
7	9032.080	FILLER OIL CAP	1
8	1200.015	O ring 137 for filler oil cap	1
9	4670.014	copper gasket diam.12	1
10	9000.064	plug	1
11	«-----»	C 21	0
12	8430.005	locating pin	2
13	2125.339	rocker arm cover	1
14	4400.061	rocker cov.gasket 0,80	2
15	9730.100	screw M 8 X 25	4
16	7565.007	washer diam. 8	4
17	4330.036	ROCK.ARM ASS.Y std	2
17	4330.064	ROCKER ARM ASS.Y 1500/1800 R.P.M.	2
18	3240.010	nut M 7	4
19	9850.002	rocker arm adjuster	4
20	6410.112	retainer with half-collets	4
21	2125.101	ROCK.ARM COVER ASS.Y	1
22	4400.061	rocker cov.gasket 0,80	2
23	1200.034	O ring 105	2
24	6095.010	cam	2
25	4330.063	ROCKER ARM ASS.Y 1500/1800 R.P.M.	2
27	9820.085	fixing screw	2
28	8430.004	tapper pin	2
29	6372.098	plate	2
30	9850.002	rocker arm adjuster	4
31	5780.011	spring	2
32	8245.005	ball	2
33	3240.010	nut M 7	4
34	8335.084	shim	2
35	8335.028	shim	8
36	6045.040	rocker arm shaft	2
37	1350.011	ring	2
38	9455.053	rocker shaft lub.pipe	2
39	1213.338	seal ring for valve	2
40	«-----»	circlip	0
41	4845.247	inlet v.guide std.	2
42	9652.153	intake valve	2
43	«-----»	eXhaust v.guide +0,50	0
43	4845.248	eXhaust v.guide std.	2
44	9685.146	exhaust valve	2
45	5755.173	valve spring	4
46	4740.024	lip seal	2
47	3430.067	spring seat (bottom)	4
48	3240.124	nut	8
49	«-----»	washer diam.10,5	0
50	3300.227	elongated nut	2
51	5200.854	GOVERNOR LEVER	1
52	7626.040	washer	1

CYLINDER HEAD/ROCKER ARM BOX/VALVES/TIMING/SPEED GOVERNOR

POS.	CODE	DESCRIPTION	Qty
53	9200.711	CYL.HEAD ASS.Y	2
54	9520.045	guard tube	2
55	4730.559	head gasket 0,45	2
55	4730.560	head gasket 0,50	2
55	4730.561	head gasket 0,55	2
55	4730.562	head gasket 0,60	2
55	4730.563	head gasket 0,65	2
55	4730.564	head gasket 0,70	2
55	4730.565	head gasket 0,75	2
55	4730.566	head gasket 0,80	2
55	4730.567	head gasket 0,85	2
55	4730.568	head gasket 0,90	2
55	4730.569	head gasket 0,95	2
55	4730.570	head gasket 1,00	2
56	4740.024	lip seal	2
57	1410.042	push rod	4
58	7215.043	tappet	4
59	1011.085	camshaft	1
60	<----->	GASKET SET - see Pos. C 60a	0
60a	8205.098	RING AND GASKET COMPLETE SET	1
61	8185.021	EMERY GASKET SET	1
62	1240.077	snap ring	1
63	8000.212	inlet v.seat	2
64	1770.150	bolt M 8 X 1,25 X 22	2
65	8000.213	eXhaust v.seat	2
66	<----->	washer	0
67	1240.005	snap ring	1
68	7626.040	washer	1
69	2280.047	key 4 X 5,5 X 16	1
70	7362.277	SPEED GOVERNOR	1
71	2086.140	governor bell	1
72	7625.333	washer diam. 6	1
73	1160.022	circlip	1
74	<----->	governor bell	0
75	1160.022	circlip	1
76	<----->	ball bearing	0
77	4882.046	GOVERNOR LEVER ASS.Y	1
78	1585.025	bushing	2
79	7626.040	washer	1
80	1240.077	snap ring	1
81	<----->	gear	0
83	1780.059	bolt M 10 X 1,5 X 35	1
84	7626.038	washer	1
85	9730.107	screw M*6 X 14	1
86	<----->	no longer avail. - see Pos. 51	0
87	7625.007	washer diam. 6	1
88	6080.022	governor push rod	1
89	8150.015	O RING SET	1
90	<----->	see Pos. D 29	0
91	1213.338	seal ring for valve	2

C
9LD

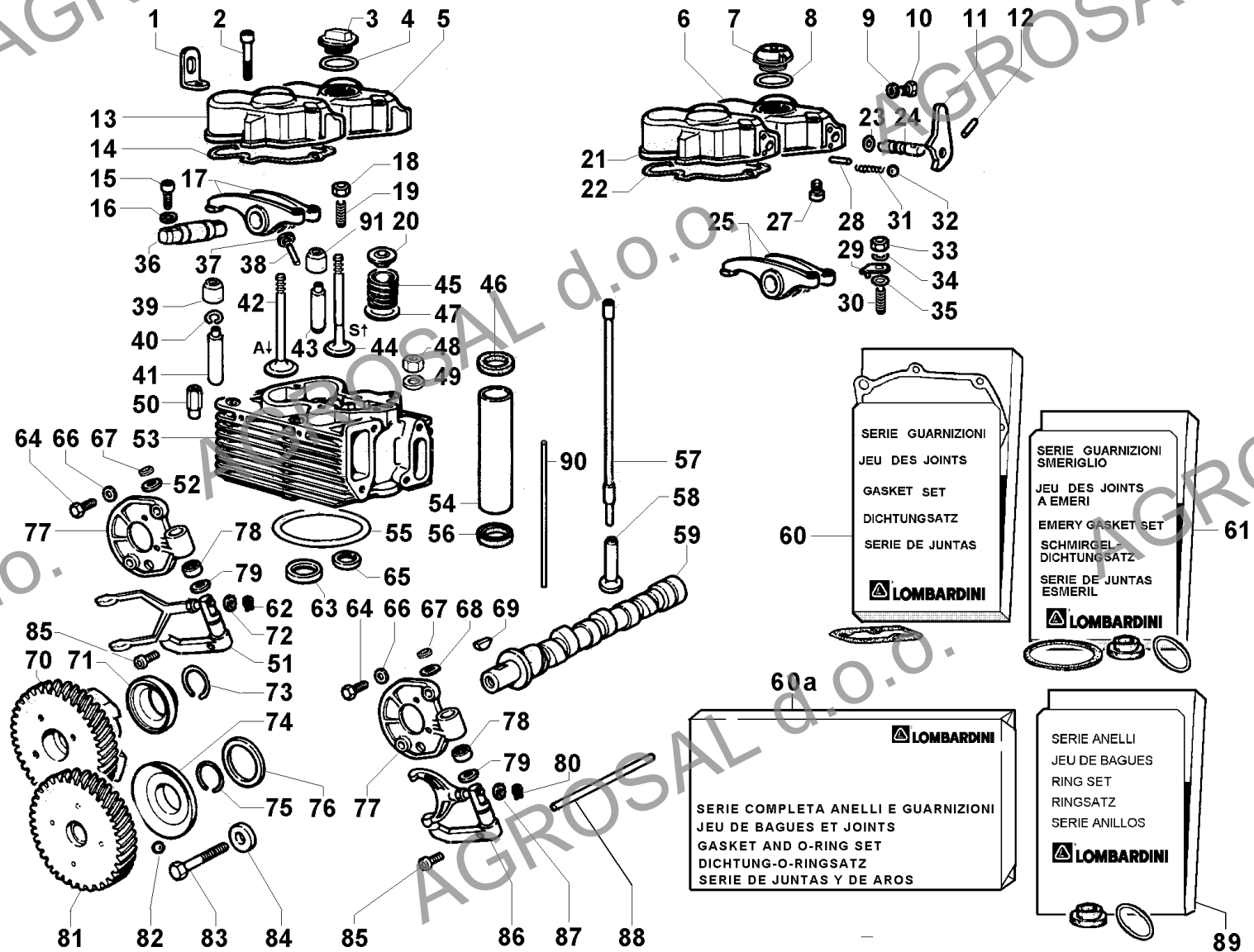

**LOMBARDINI**

A KOHLER COMPANY

Group: 9LD

Engine: 9LD 561-2 Drawing: E

FUEL SYSTEM

POS.	CODE	DESCRIPTION	Qty
1	9371.100	bleeding pipe mm 536	1
1	9371.101	bleeding pipe mm 745	1
2	4670.058	copper gasket diam. 8,2X12X1,5	1
3	1901.029	union bolt M 8	1
4	4670.058	copper gasket diam. 8,2X12X1,5	1
5	1901.029	union bolt M 8	1
6	3616.082	fuel tank strap	2
7	9043.092	fuel tank cap	1
8	9043.025	fuel tank cap	1
9	9761.001	screw M 4 X 0,7 X 12	6
10	4776.040	gasket	1
11	5055.023	plate	1
12	4906.008	fuel gauge (mm 193) 15/29 lt	1
13	3790.074	injector top plate	2
14	3203.050	selflocking nut M 6	4
15	7565.004	washer diam. 6	4
16	6760.045	stud M 6 X 65 (80)	4
17	9376.056	rear high pressure pipe	1
18	4670.058	copper gasket diam. 8,2X12X1,5	1
20	9730.115	screw M 5 X 14	2
21	3616.018	injector feed pipe saddle	2
22	5400.046	rubber sheathing	2
23	9730.139	screw M 6 X 60	2
24	1557.019	drilled block	2
25	1557.020	threaded block	2
26	8102.085	FUEL TANK 10 lt (410X190X140)	1
27	8103.021	fuel tank 15 liters	1
28	8430.036	locking needle	2
29	6615.018	NOZZLE-HOLDER	2
30	6531.265	nozzle	2
31	«-----»	gasket	0
32	4670.005	copper gasket 0,50	2
32	4670.006	copper gasket 1,00	2
33	7301.006	connection	2
34	9376.057	front high pr.pipe	1
35	3616.085	fuel tank strap mm 625	2
36	9600.057	rubber spacer	4
37	8315.016	rubber shim	1
38	8042.024	fuel tank saddle	1
39	3586.058	electric valve	1
40	3440.055	QSD STOP DEVICE	1
42	7265.008	connection	2
43	1200.031	rubber oil seal	2
44	4701.006	gasket	1
45	8866.018	support	1
46	7470.003	filler	2
47	8335.029	washer seal	2
48	5755.034	valve spring	2
50	9372.034	fuel hose (mm 630)	1
50	9375.032	fuel hose mm 336	1
50b	9375.142	fuel hose mm 1100	1
51	4760.015	valve gasket	2
52	6578.013	Injection plunger	2

Group: 9LD
Engine: 9LD 561-2 Drawing: E

FUEL SYSTEM			
POS.	CODE	DESCRIPTION	Qty
53	1770.156	bolt M 8 X 1,25 X 25	3
54	7625.010	washer diam. 8	4
55	9672.012	delivery valve BOSCH	2
56	8400.048	taper pin	1
57	1901.031	union bolt M 12	1
57a	1901.152	union bolt M 12 l=51	1
58	1901.101	union bolt l=60	1
59	9730.026	screw M 8 X 20	4
60	1901.171	deaeration plug	1
61	4775.196	gasket	1
62	1901.171	deaeration plug	1
62a	1901.029	union bolt M 8	1
63	4670.060	copper gasket diam.12	2
65	7565.007	washer diam. 8	4
66	1901.033	union bolt M 6	1
67	4670.062	copper gasket diam. 6,2 X 10 X 1,5	3
68	5575.006	spring	1
69	3930.019	cup	1
70	1200.268	rubber oil seal	1
71	2175.009	fuel filter cartridge	1
71	3730.015	FUEL FILTER	1
72	4490.017	gasket	1
73	4430.071	gasket	1
74	6370.515	tank plate	1
75	8636.001	vibration-damping	4
76	9043.092	fuel tank cap	1
77	8866.067	support	2
78	1701.029	rubber shim	2
79	9245.076	stay bolt	4
80	8760.038	fuel filter support	1
81	2175.045	fuel filter cartridge	1
82	8760.055	fuel filter support	1
83	3730.153	FUEL FILTER	1
84	6590.034	injection pump	1
85	«-----»	no longer available	0
86	4580.002	gasket 0,10	1
86	4580.009	gasket 0,50	1
86	4580.068	gasket 0,05	1
86	4580.193	gasket 0,30	1
87	1580.023	bushing	1
88	771R.001	washer diam. 5,3	1
89	9375.351	fuel hose (mm 190)	1
90	2800.003	cotter pin	1
91	7270.104	banjo union diam.10	1
92	3587.103	el.valve (12V)on injection pump	1
93	1901.031	union bolt M 12	1
94	4670.060	copper gasket diam.12	2
95	9375.005	fuel hose	1
96	«-----»	union	0
98	2605.033	filter cover	1
99	1202.052	rubber oil seal	1
101	3630.008	clamp	1
102	1901.032	union bolt M 14	1

Group: 9LD
Engine: 9LD 561-2 Drawing: E

FUEL SYSTEM			
POS.	CODE	DESCRIPTION	Qty
103	4670.061	copper gasket diam.14	2
104	4850.009	guide	1
105	7980.020	cup	2
106	«----»	injector rack	0
109	1901.030	union bolt M 10	1
110	1760.162	bolt	1
110	7200.078	drive rod	1
111	4670.059	copper gasket diam.10	2
112	«-----»	sleeve (no longer avail.)	0
113	6230.069	pin	1
114	9375.276	fuel hose mm 430	1
114	9375.859	del.pipe mm 1000	1
115	9375.308	fuel pipe mm 2000	1
116	3587.105	el.valve 12V on engine	1
117	4670.059	copper gasket diam.10	4
118	8103.308	FUEL TANK (29 liters)	1
119	4701.030	rubber shim	2
120	8866.066	support	2
121	8635.059	vibration-damping	4
124	2175.046	fuel filter cartridge	1
125	3730.151	fuel filter	1
126	2175.046	fuel filter cartridge	1
127	5625.002	spring	2
128	4670.061	copper gasket diam.14	2
129	1901.032	union bolt M 14	1
130	6230.068	pin	2
131	«----»	spring retainer bottom - see Pos. E 84	0
132	7215.017	tappet	2
133	«-----»	no longer available	0
136	1200.087	O ring 3150	1
137	6780.008	stud M 8 X 20 (32)	2
138	9375.853	fuel pipe mm 1000	1
138	9375.854	fuel hose (mm 680)	1
139	6585.096	feed pump	1
140	1901.030	union bolt M 10	1
141	4670.059	copper gasket diam.10	2
142	3240.164	nut M 8	2
143	9375.596	fuel hose	1
144	1901.030	union bolt M 10	2
145	8866.032	support	1
147	5111.062	lock plate	2
180	7555.029	washer diam. 8	2
181	1901.030	union bolt M 10	1
182	4670.059	copper gasket diam.10	2
213	5801.037	spring	1
214	8245.003	gov.ball diam. 4,8 3/16''	1

