

***AGROSAL d.o.o.***



**LOMBARDINI**  
A KOHLERCOMPANY

**11M 250**



***AGROSAL d.o.o.***

Gregorčičeva ulica 38, 5270 Ajdovščina  
telefon: 05 368 90 96, fax: 05 368 90 97  
e-mail: [info@agrosal.si](mailto:info@agrosal.si), [www.agrosal.si](http://www.agrosal.si)

**INTAKE AND EXHAUST**

POS.	CODE	DESCRIPTION	Qty
1	7626.064	washer diam. 8,25	2
2	7625.010	washer diam. 8	1
3	7565.007	washer diam. 8	1
4	1770.004	bolt M 8 x 1,25 x 20	1
5	<----->	bracket	0
6	3240.004	nut M 5	2
7	5460.460	exhaust muffler	1
7a	<----->	exhaust muffler	0
8	6927.367	muffler guard	1
8a	<----->	muffler guard	0
9	7625.007	washer diam. 6	4
10	9790.037	screw M 6 x 8	4
11	9790.028	screw M 5 x 10	2
12	3790.062	flange	1
13	<----->	see remarks	0
16	3700.323	DRY AIRCLEANER (denoised type)	1
17	7625.008	washer diam. 6,4	2
18	9730.012	screw M 6 x 20	2
19	4775.495	gasket	1
20	<----->	see Pos.A 16	0
21	771R.001	washer diam. 5,3	2
22	<----->	see Pos. A 22a	0
22a	5460.410	exhaust muffler	1
23	7565.004	washer diam. 6	2
24	<----->	nut M 6	0
26	6927.463	muffler guard	1
27	<----->	see remarks	0
27a	5460.522	exhaust muffler	1
28	3930.060	cup	1
29	5496.062	filtering element	1
30	<----->	screw M 3,5 x 13	0
31	2605.044	air cleaner cover	1
32	1760.003	bolt M 6 x 1 x 12	2
33	7565.004	washer diam. 6	2
80	3360.039	guard	1
81	3630.156	clamp diam.20-32	1
82	4490.072	gasket	1
83	7870.034	air cleaner support	1
84	8180.186	gasket set	1
86	6370.140	plate	4
87	2183.098	hinge link	2
89	4501.136	gasket	1

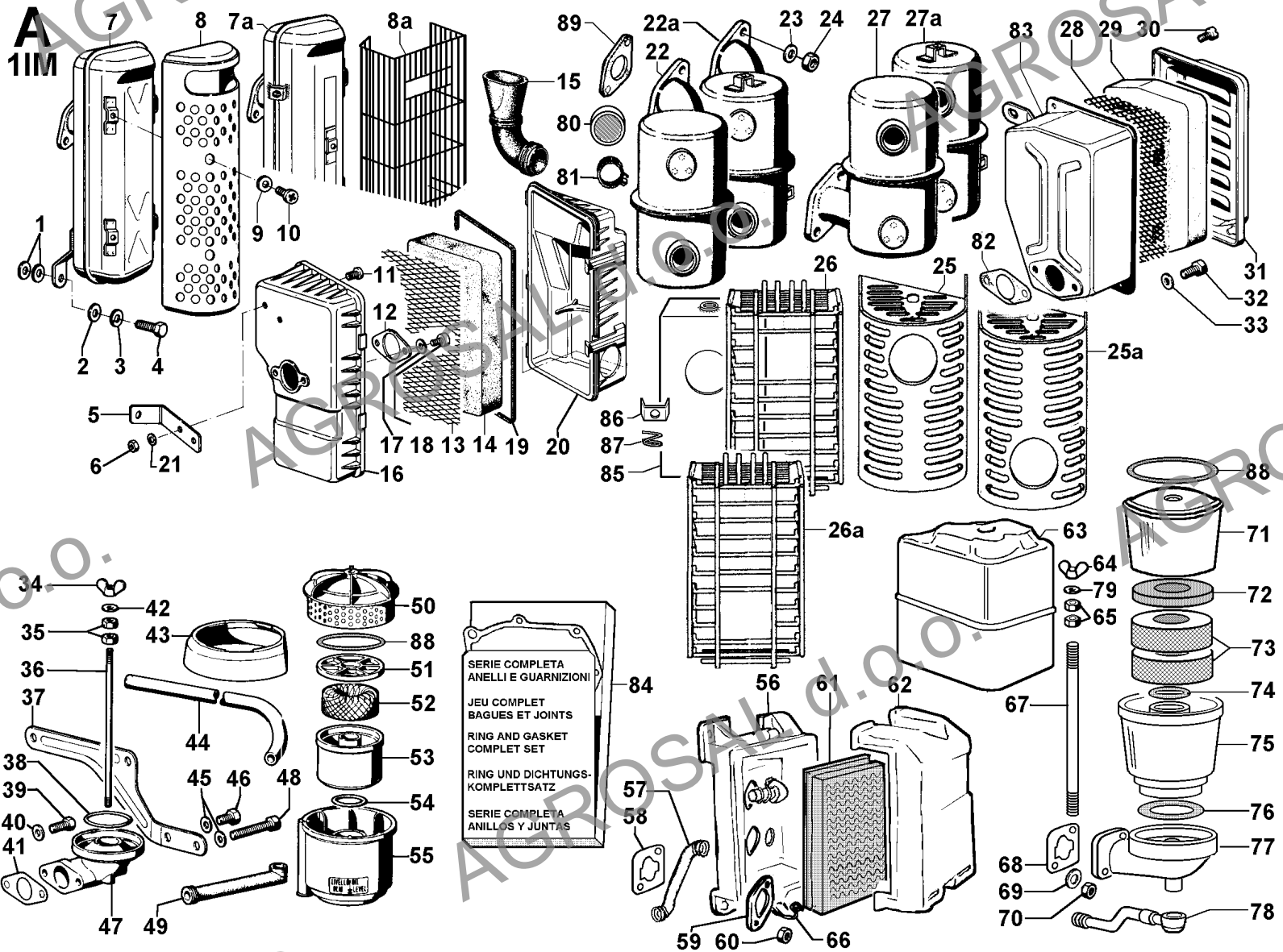

**CARBURETOR**

POS.	CODE	DESCRIPTION	Qty
1	6100.029	butterfly shaft	1
3	9820.112	screw	1
4	5801.141	spring	1
6	7996.014	mixture tube seat	1
8	8588.028	mixture tube	1
9	7996.013	mixture tube seat	1
10	1200.172	O ring	1
11	4126.016	idle jet 0,40	1
12	1200.173	O ring	1
13	6610.004	jet holder	1
14	<----->	main jet 0,94	0
14	4126.017	main jet 0,90	1
15	6610.003	jet holder	1
19	3730.041	fuel filter	1
20	6491.021	spark plug elbow	1
22	4105.019	float	1
23	<----->	pin	0
24	9850.073	screw	1
25	5801.141	spring	1
26	9820.113	screw	1
30	5801.142	spring	1
31	6100.035	butterfly shaft	1
32	8180.167	carburetor parts set	1

**H**  
**1IM**

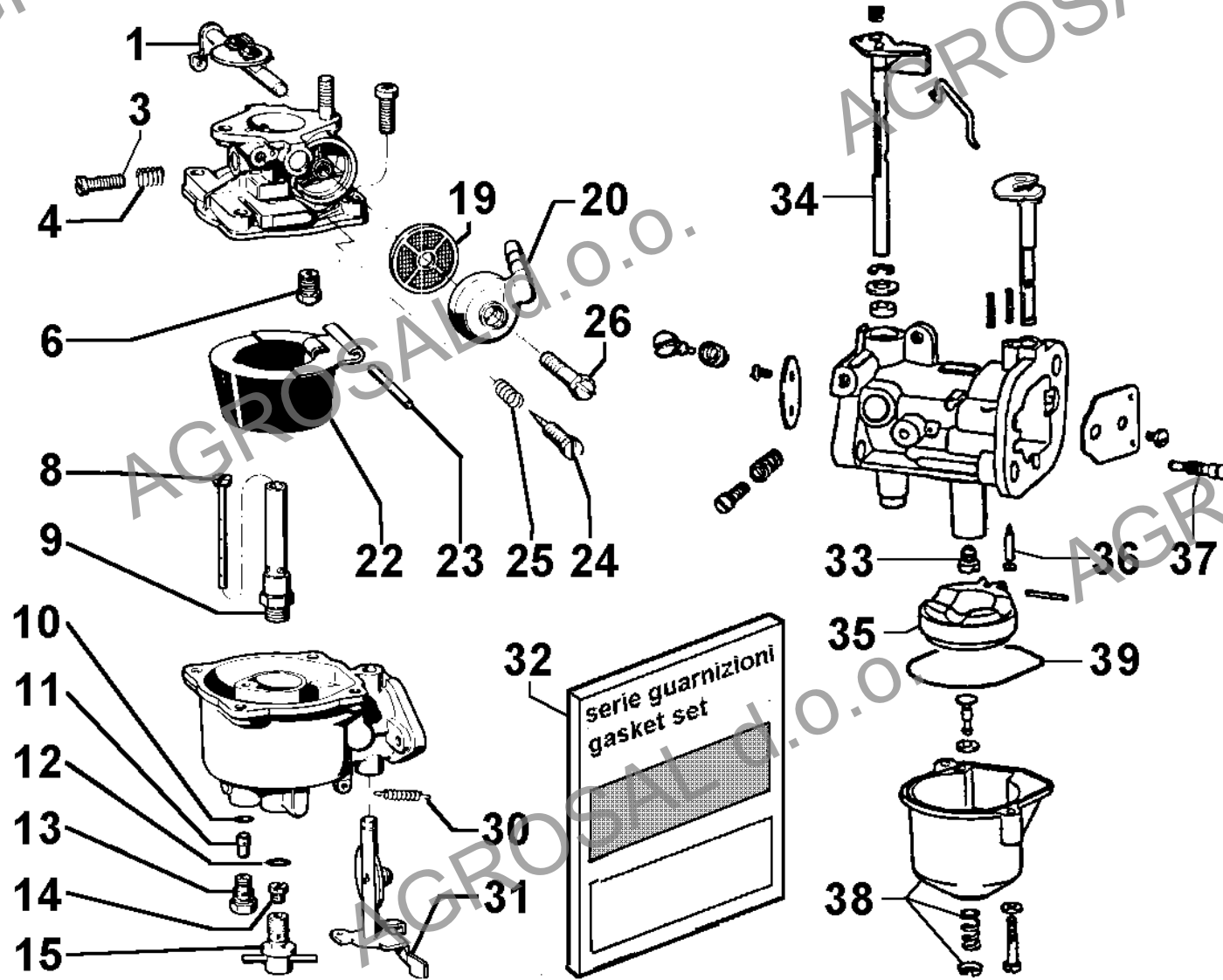

**LOMBARDINI**

Group: 1IM

A KOHLER COMPANY

Engine: 1IM 250 Drawing: B

**CONNECTING ROD/PISTON SET**

POS.	CODE	DESCRIPTION	Qty
1	1261.070	pin ring	2
2	8480.002	gudgeon pin	1
3	1526.026	CONNECTING ROD std	1
3	1526.027	CONNECTING ROD -0,25	1
3	1526.028	CONNECTING ROD -0,50	1
4	6330.055	plate	1
5	1760.030	bolt M 6 x 45	2
6	6502.080	PISTON SET std	1
6	6502.082	PISTON SET +0,50	1
6	6502.083	PISTON SET +1,00	1
7	8210.096	ring set std.	1
7	8210.097	ring set +0,50	1
7	8210.098	ring set +1,00	1
8	5168.055	oil dipper	1

# B

## 1IM

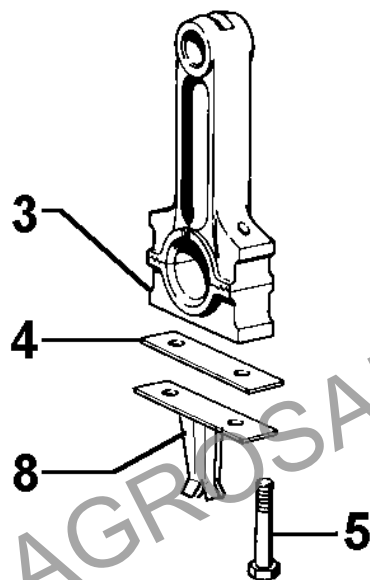
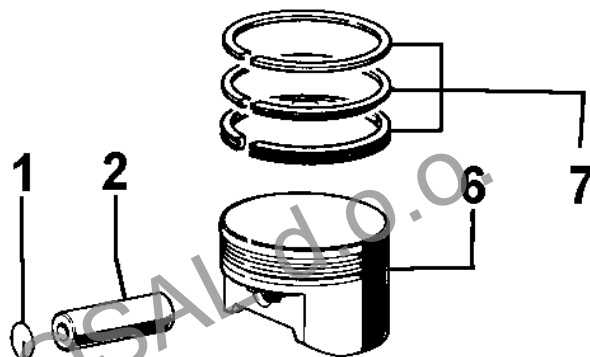

**CONTROLS**

POS.	CODE	DESCRIPTION	Qty
1	<----->	see Pos.L 5	0
2	5200.606	lever	1
3	3203.038	nut M 5x0,8	1
4	9790.028	screw M 5 x 10	2
5	2750.282	hand control cover	1
6	1165.006	circlip diam. 7	1
7	5200.202	lever	1
8	5680.119	spring	1
9	6140.137	pin	1
10	3200.015	wing nut	1
11	<----->	see Pos.L 5	0
12	7626.054	washer diam. 5,3	1
13	<----->	see Pos.L 5	0
15	5655.047	governor spring std	1
15	5655.108	governor spring for generating sets 1500/3000 rpm	1
16	1760.034	bolt M 6 x 25	1
16	1760.086	bolt M 6x30	1
17	3240.008	nut M 6	1
18	1557.058	nut	1
19	1760.082	bolt M 6 x 35	1
20	4680.039	gasket	1
21	7951.109	BREATHER BOx	1
22	5976.005	filtering element	1
23	4680.039	gasket	1
24	9695.013	breather valve	1
25	2690.046	breather cap	1
25	2690.288	breather cap (denoised type)	1
26	9790.039	screw M 6 x 12	1
27	9580.023	breather line	1
28	2691.051	remote control cover	1
29	5830.119	nut	1
30	9180.191	adjuster M 6	1
31	3240.009	nut M 6	1



**L**  
**1IM**

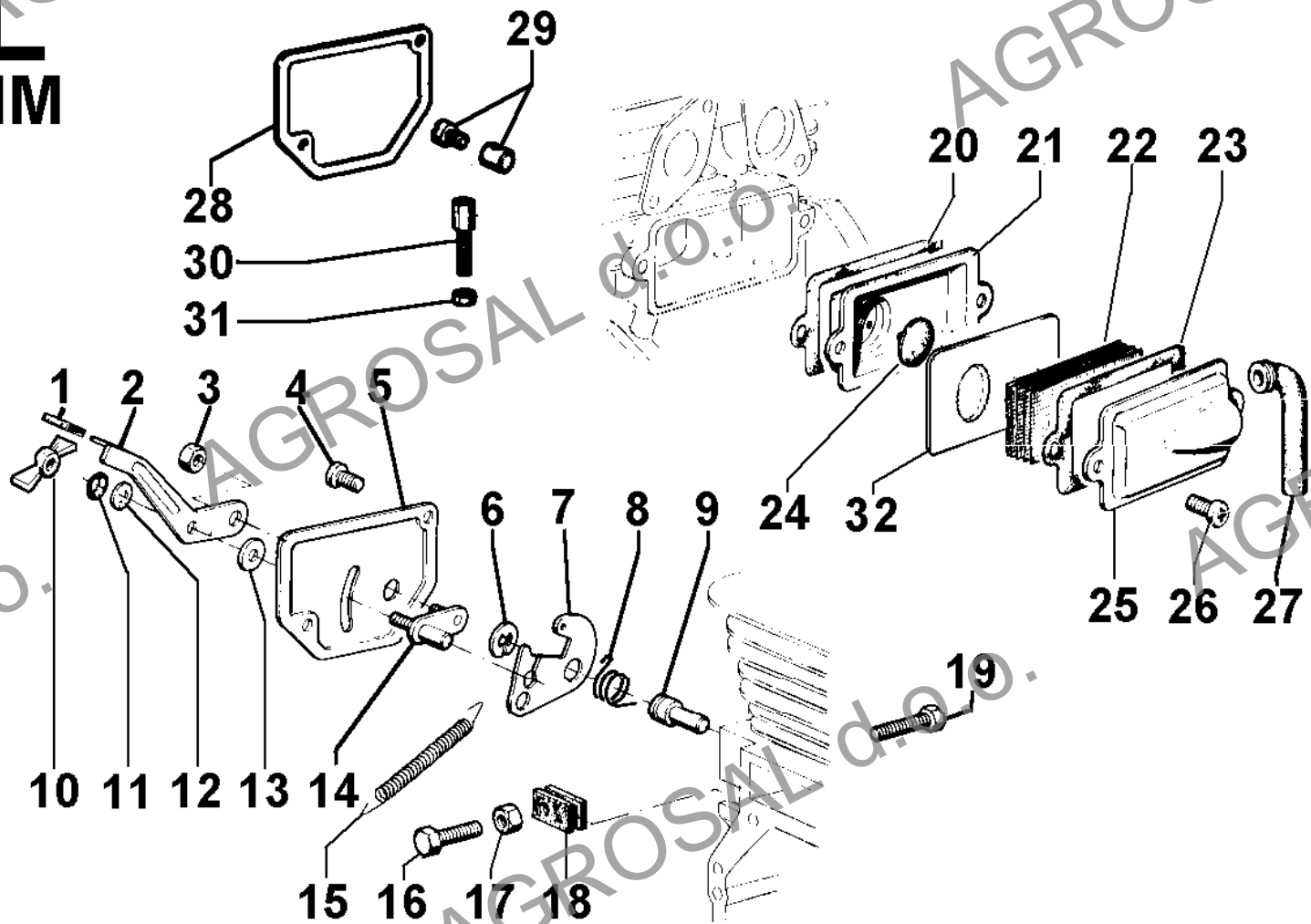

**LOMBARDINI**

Group: 1IM

A KOHLER COMPANY

Engine: 1IM 250 Drawing: I

**COOLING PANELS**

POS.	CODE	DESCRIPTION	Qty
1	7481.025	nail	2
2	7195.003	drive rod	1
3	<----->	earth spring	0
4	7500.018	washer	2
5	9790.039	screw M 6 x 12	2
8	2920.170	hood std	1
9	<----->	gasket	0
10	2568.069	shroud (el.start.)	1
10	2569.393	shroud	1
11	9790.037	screw M 6 x 8	4
12	7500.018	washer	2
25	<----->	shroud for electric starting and oil level warning	0
26	8345.039	OIL LEVEL WARNING	1
27	<----->	see Pos.I 26	0
29	5096.064	guard	1

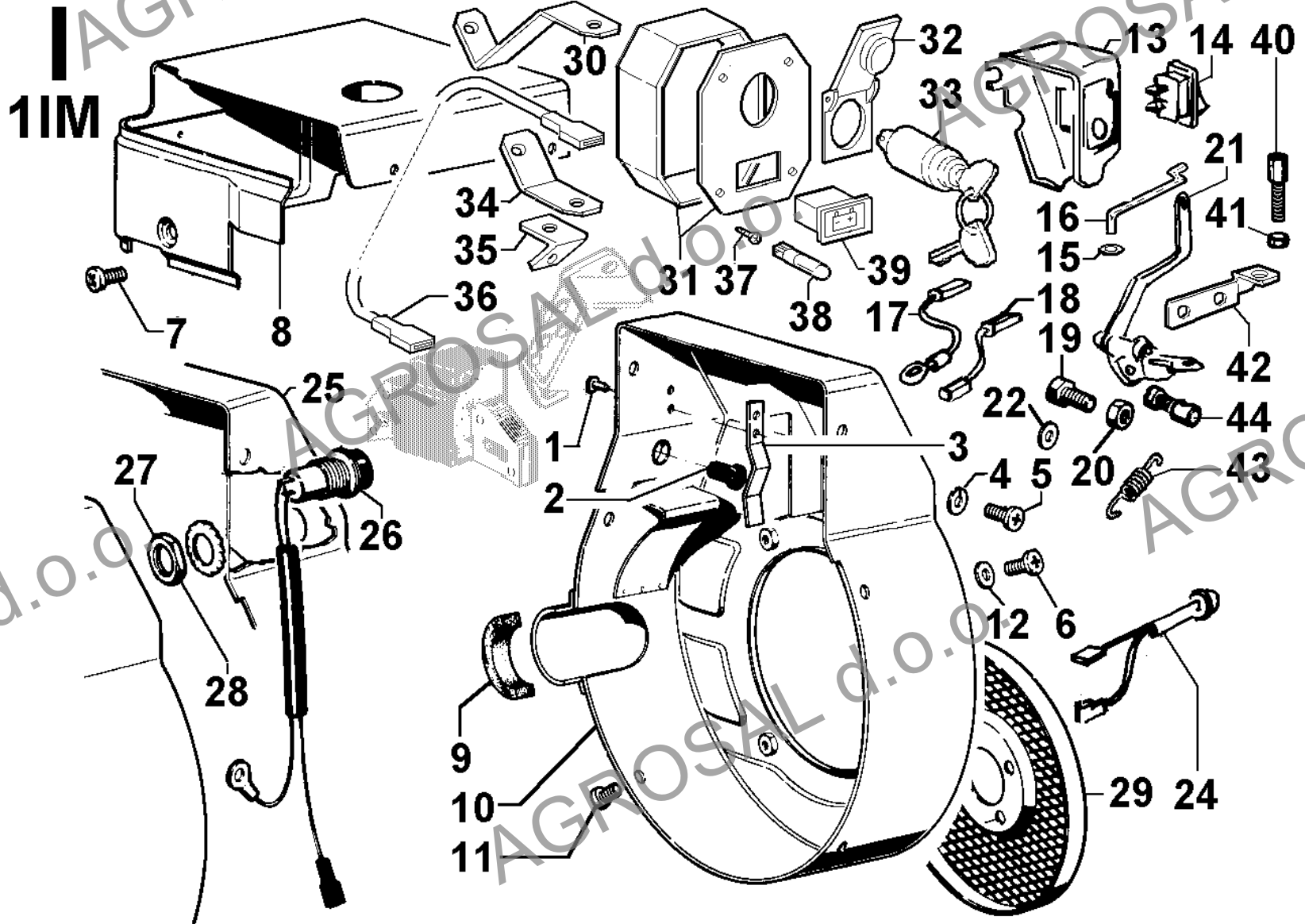

**CRANKCASE/GEAR COVER/MOUNTS**

POS.	CODE	DESCRIPTION	Qty
1	1400.449	dipstick on cyl.head	1
2	9485.217	dipstick tube for el.starting	1
3a	<----->	CRANKCASE suitable for rewind starter only - see notes	0
4	8000.122	exhaust v.seat	1
5	8000.121	inlet v.seat	1
6	4845.028	exh. valve guide	1
7	6760.047	stud M 6 x 16	1
9	1901.014	union bolt 1/4 GAS	1
10	9032.056	dipstick	1
11	9765.058	screw M 16 x 16	1
12	1213.056	seal ring 28 x 38 x 7	1
13	6645.263	gear cover	1
14	3001.070	ball bearing 30x62x16	1
15	4350.006	gasket	2
16	1200.003	O ring 118	1
17	1213.002	seal ring 28 x 38 x 7	1
18	9732.060	screw M 6 x 35	9
19	4601.029	gasket	1
20	8460.083	lockpin	2
21	3440.035	oil alert device	1
22	1200.082	O ring 3106	1
23	7555.003	washer diam. 5	2
24	9730.115	screw M 5 x 14	2
25	6370.333	plate	1
26	8980.010	plug	1
27	4350.006	gasket	1
28	1770.002	bolt M 8 x 1,25 x 16	8
29	7565.007	washer diam. 8	8
30	4845.203	inlet valve guide	1
31	4535.015	valve retainer	1
35	<----->	electronic device	0
38	6429.173	engine mount	2
39	<----->	gasket	0

**D**  
**1IM**

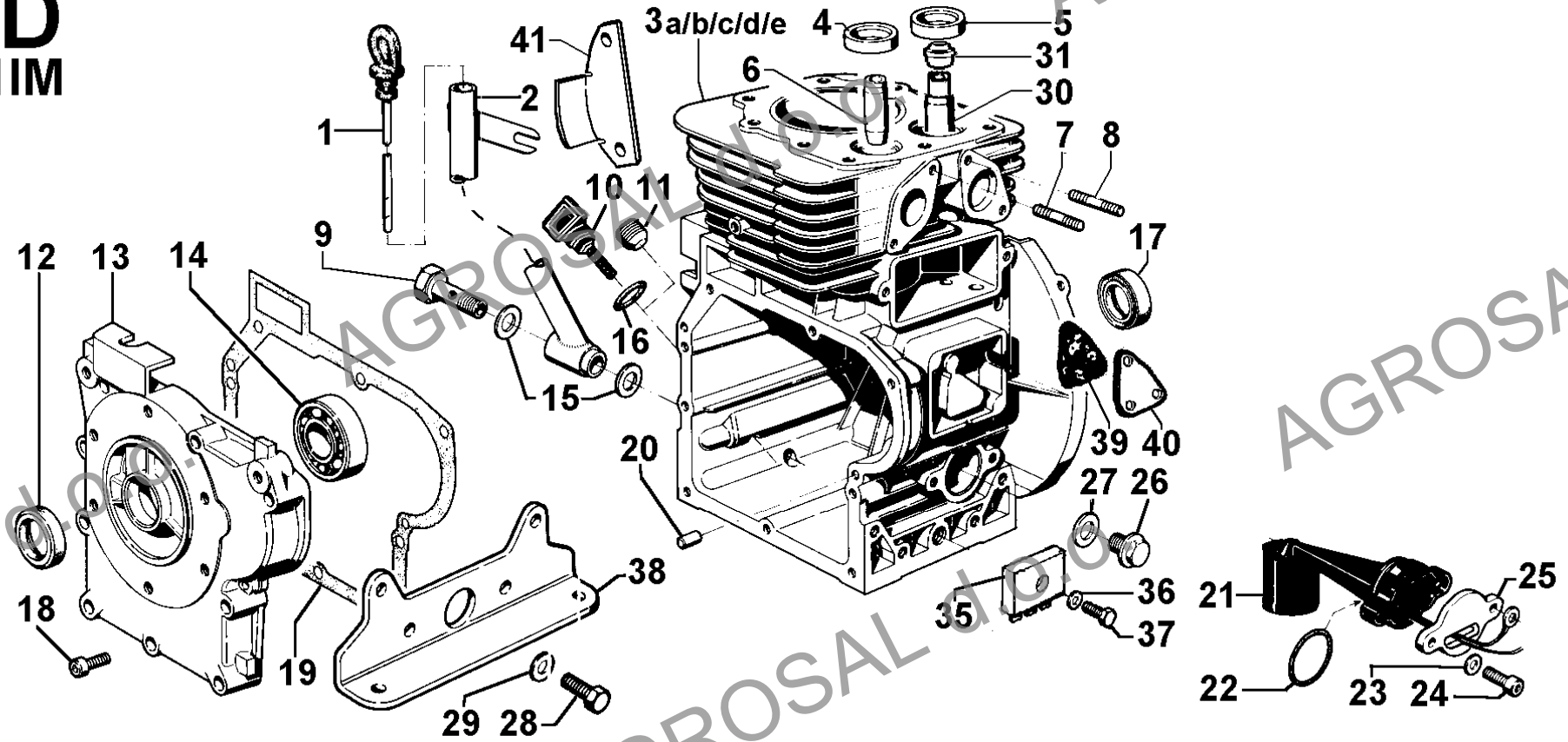

**CRANKSHAFT/FLYWHEEL**

POS.	CODE	DESCRIPTION	Qty
1	<----->	nail	0
2	2194.014	oil baffle	1
3	<----->	CRANKSHAFT Ext 8 SAE J609	0
3	1050.729	CRANKSHAFT std	1
4	<----->	plug (no longer avail.)	0
5	3001.070	ball bearing 30x62x16	1
6	2816.034	crown gear	1
7	<----->	flywheel	0
7a	9881.436	FLYWHEEL with CROWN	1
8	7530.018	washer	1
9	3260.055	nut M 16 x 1,5 left	1
10	1770.039	bolt M 8 x 1,25 x 28	1
11	7625.060	washer diam. 8,4	1
12	<----->	gear	0
13	2280.142	key std	1
14	<----->	key 4,76 x 4,76 x 50,8	0
14	2280.050	key 6,32 x 6,32 x 60	1
14	2280.052	key 6,35x9,52x22,225	1
15	<----->	CRANKSHAFT ext 3 SAE J609 - no longer avail.	0
15	+B2A.046	CRANKSHAFT ext A3	1
16	7750.075	alternator rotor	1
17	8565.072	alternator stator 12 V 8,5 A - 3 wires	1

**C**  
**1IM**

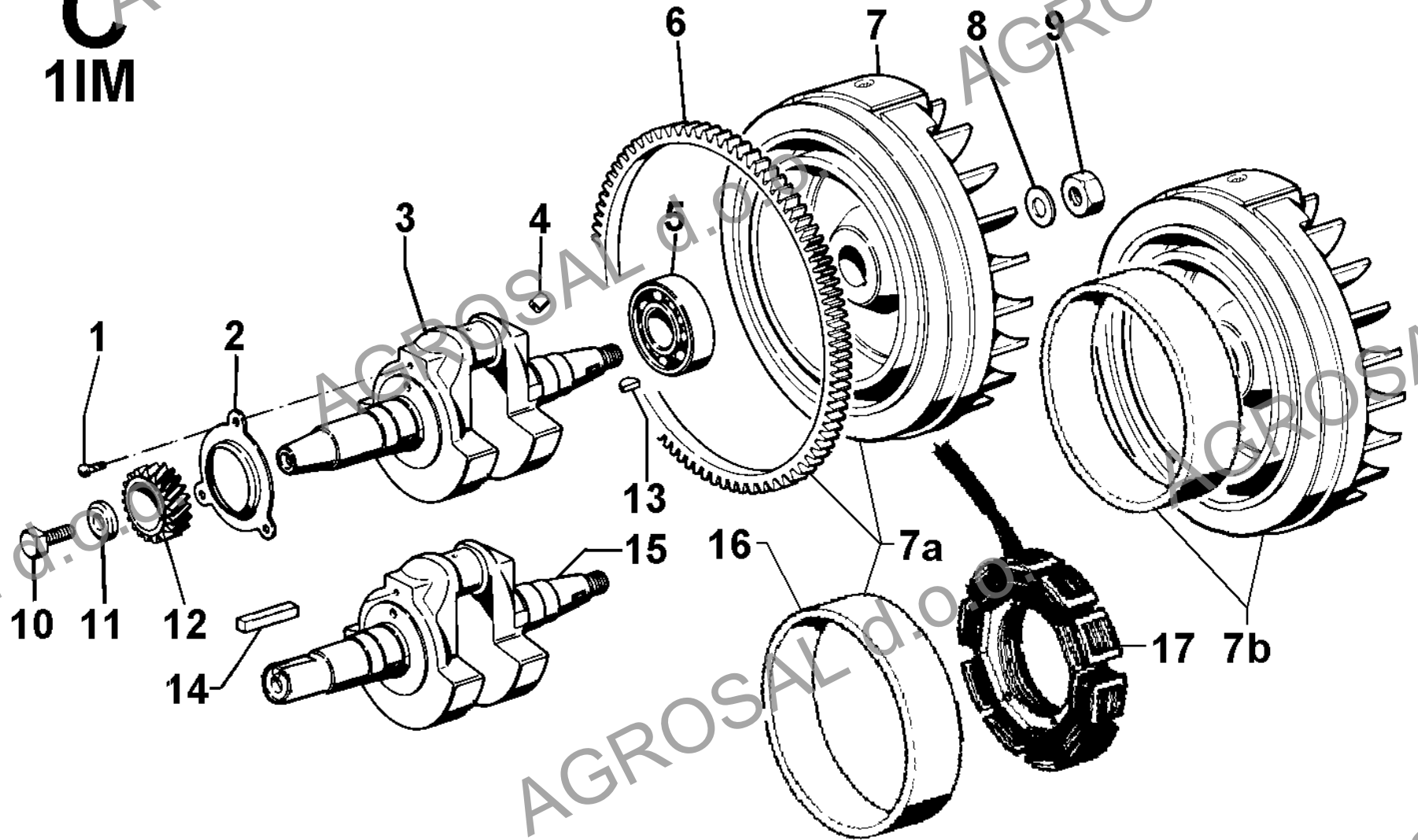

**LOMBARDINI**

Group: 1IM

A KOHLER COMPANY

Engine: 1IM 250 Drawing: F

**CYLINDER HEAD AND IGNITION**

POS.	CODE	DESCRIPTION	Qty
1	1450.001	spark plug cap std	1
1a	1450.128	spark plug cap	1
2	6900.037	extension std	1
2	6902.157	extension	1
3	2135.049	cap	1
4	1780.128	bolt M 10x50 (2,5 Kgm)	9
5	7625.273	washer diam.10,5x20x5	9
6	<----->	cilynder head	0
7	147A.131	spark plug for unloaded petrol	1
8	5400.007	sheath	1
9	2187.002	spark plug wire	1
10	2470.054	hink	1
11	9790.039	screw M 6 x 12	1
12	3240.003	nut M 4	2
13	4730.530	head gasket	1
14	1750.037	bolt M 4x25	1
15	8770.029	support	1
16a	1567.212	COIL	1
17	<----->	spacer	0
18	7625.007	washer diam. 6	1
19	1760.006	bolt M 6 x 1 x 20	2
19	1760.008	bolt M 6 x 25	2
20	<----->	cap	0



**F**  
**1IM**

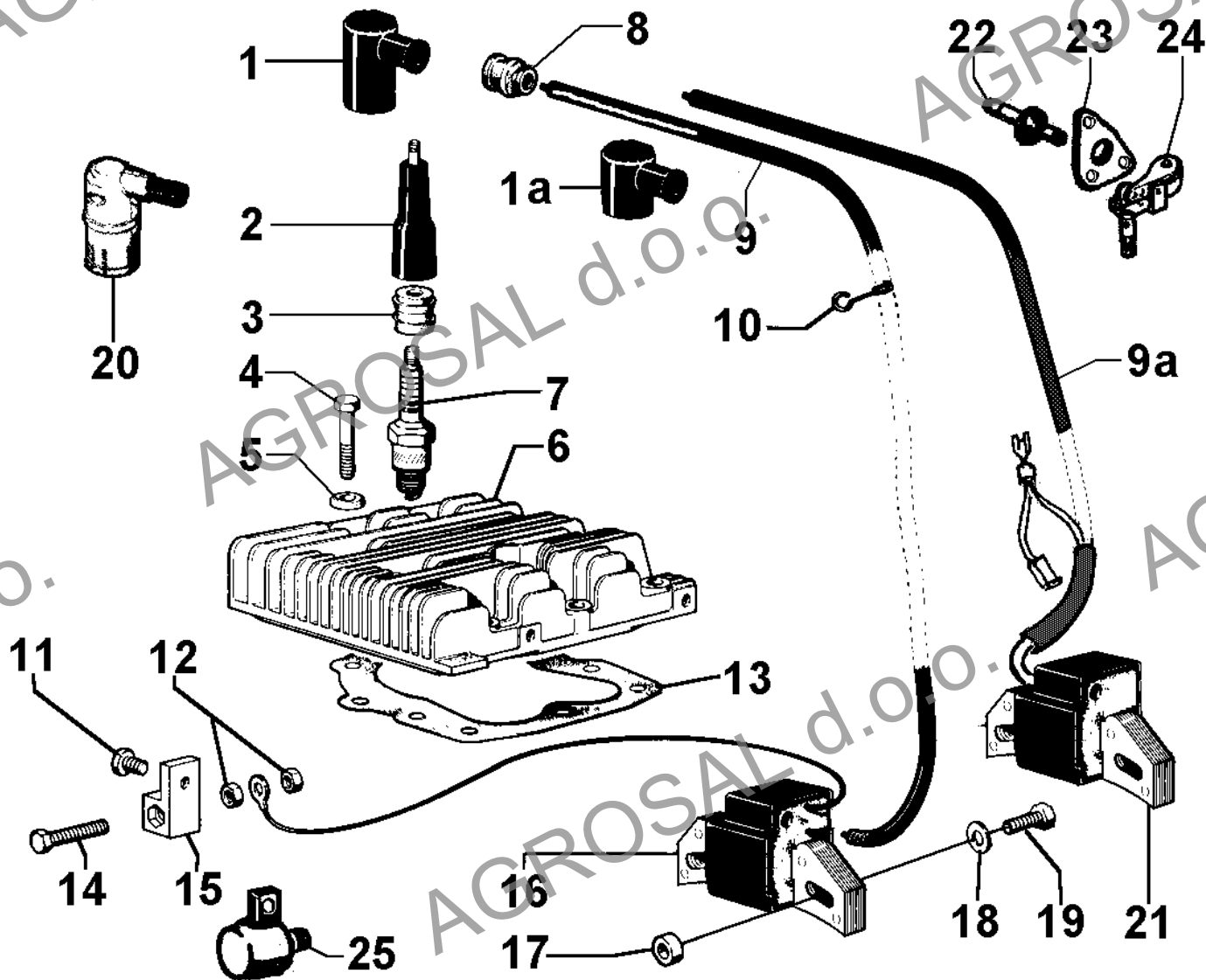

**LOMBARDINI**

Group: 1IM

A KOHLER COMPANY

Engine: 1IM 250 Drawing: G

**FUEL SYSTEM**

POS.	CODE	DESCRIPTION	Qty
1	8103.203	fuel tank std	1
1	8103.247	fuel tank	1
1a	8103.272	fuel tank motorcultivator	1
2	5401.023	sheath	1
3	9080.131	TANK CAP	1
4	4775.469	gasket	1
5	7555.003	washer diam. 5	2
6	3240.008	nut M 6	2
7	9375.196	fuel hose	1
8	7500.018	washer	2
9	9790.039	screw M 6 x 12	2
10	4580.186	seal gasket	1
10a	3240.132	nut M 10 for shut off valve p.no 7755.102	1
11	<----->	shut off valve for fuel tank pos. G 1 (8103.247)	0
11	7755.055	shut off valve for fuel tank pos. G 1 (8103.203/8103.272)	1
12	7500.018	washer	2
13	9790.039	screw M 6 x 12	2
14	4501.107	gasket	2
15	<----->	guard	0
16	2942.133	carburetor elbow	1
17	4470.013	gasket	1
18	7565.004	washer diam. 6	2
19	3240.008	nut M 6	2
20	2151.237	carburetor	1
21	<----->	panel	0
22	4501.136	gasket	1
25	<----->	see Pos.G 3	0
30	3630.057	clamp	3
31	9375.196	fuel hose	1
32	1760.001	bolt M 6 x 1 x 10	1
33	9375.196	fuel hose	1
34	8546.037	bracket	1
35	9375.196	fuel hose	1
36	3617.037	clamp	1
37	9375.196	fuel hose	1
38	3617.018	clamp	1
39	3630.057	clamp	1
40	9375.196	fuel hose	1
41	7755.062	shut off valve for motorcultivator version	1

**G**  
**IIM**

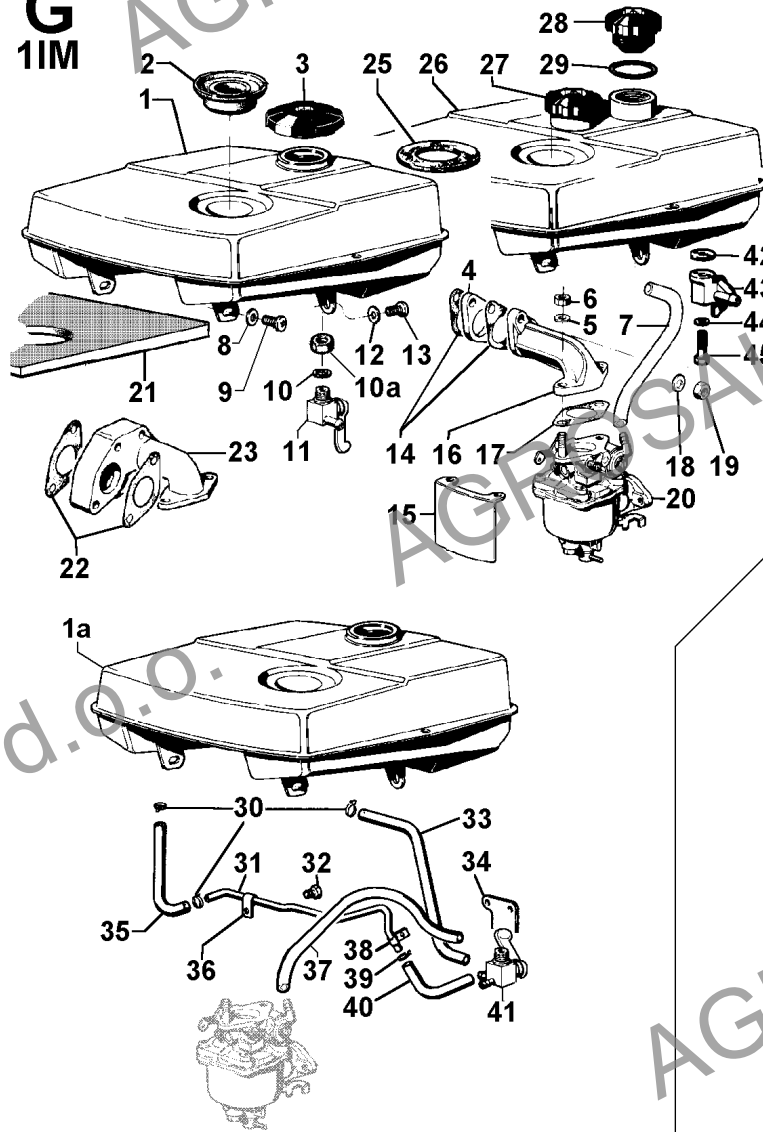

**RESTYLING**

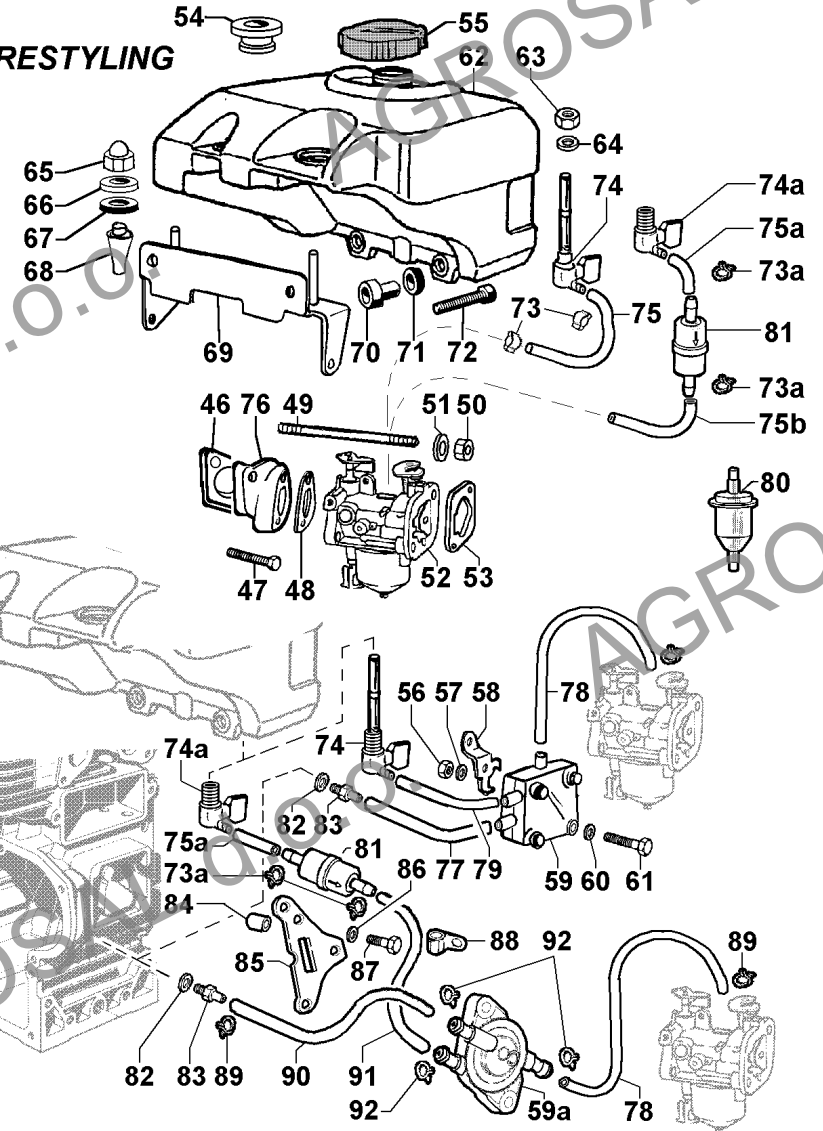



**LOMBARDINI**

Group: 1IM

A KOHLER COMPANY

Engine: 1IM 250

Drawing: Z

**SHORT BLOCK**

POS.	CODE	DESCRIPTION	Qty
1	←-----→	short block not available	0

**Z**  
**1IM**

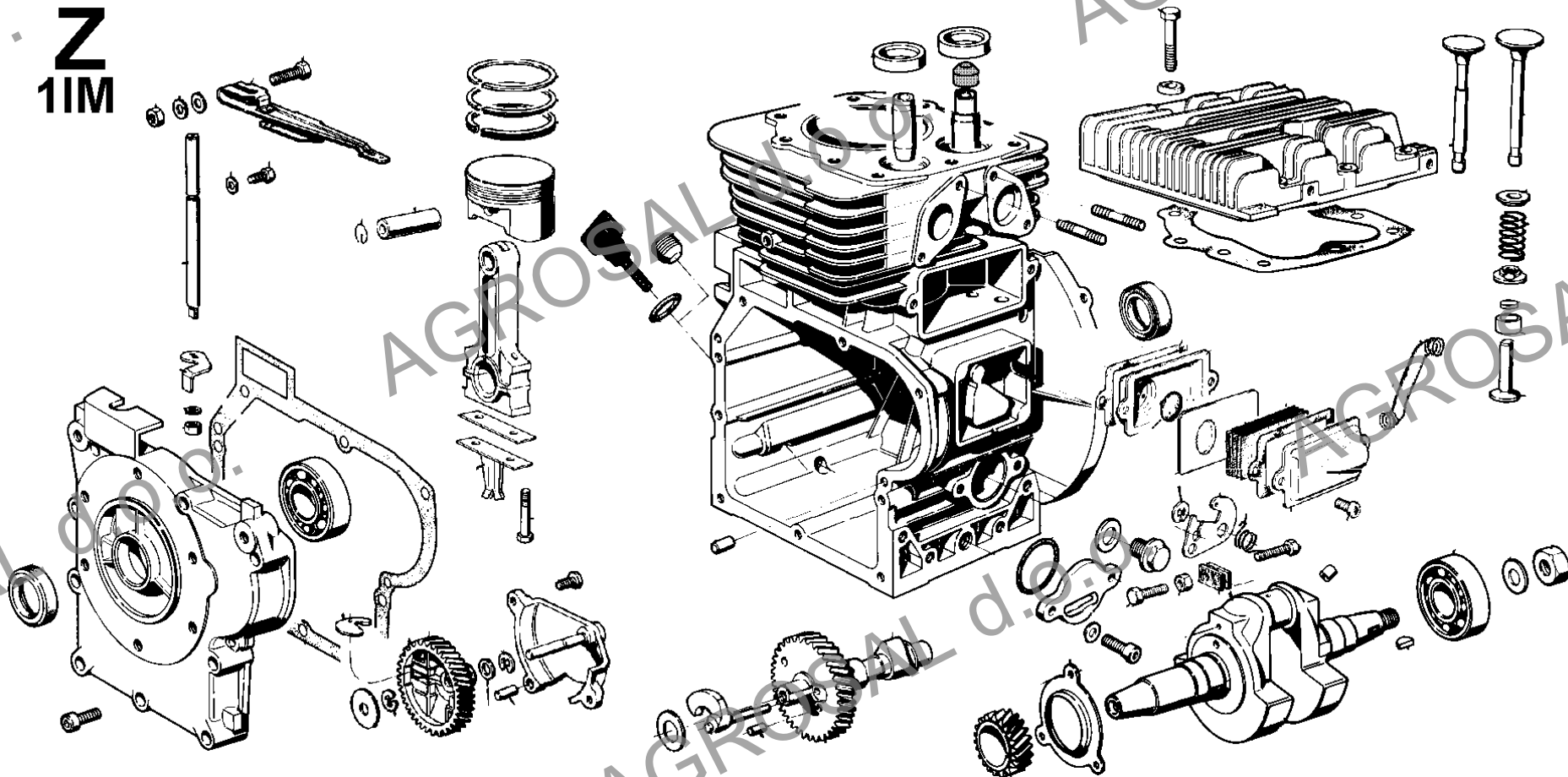



**LOMBARDINI**

Group: 1IM

A KOHLER COMPANY

Engine: 1IM 250

Drawing: N

**SOUNDPROOFING**

POS.	CODE	DESCRIPTION	Qty
4	<----->	panel	0
5	3300-190	drilling plate	2
6	<----->	guard	0

**N**  
**1IM**

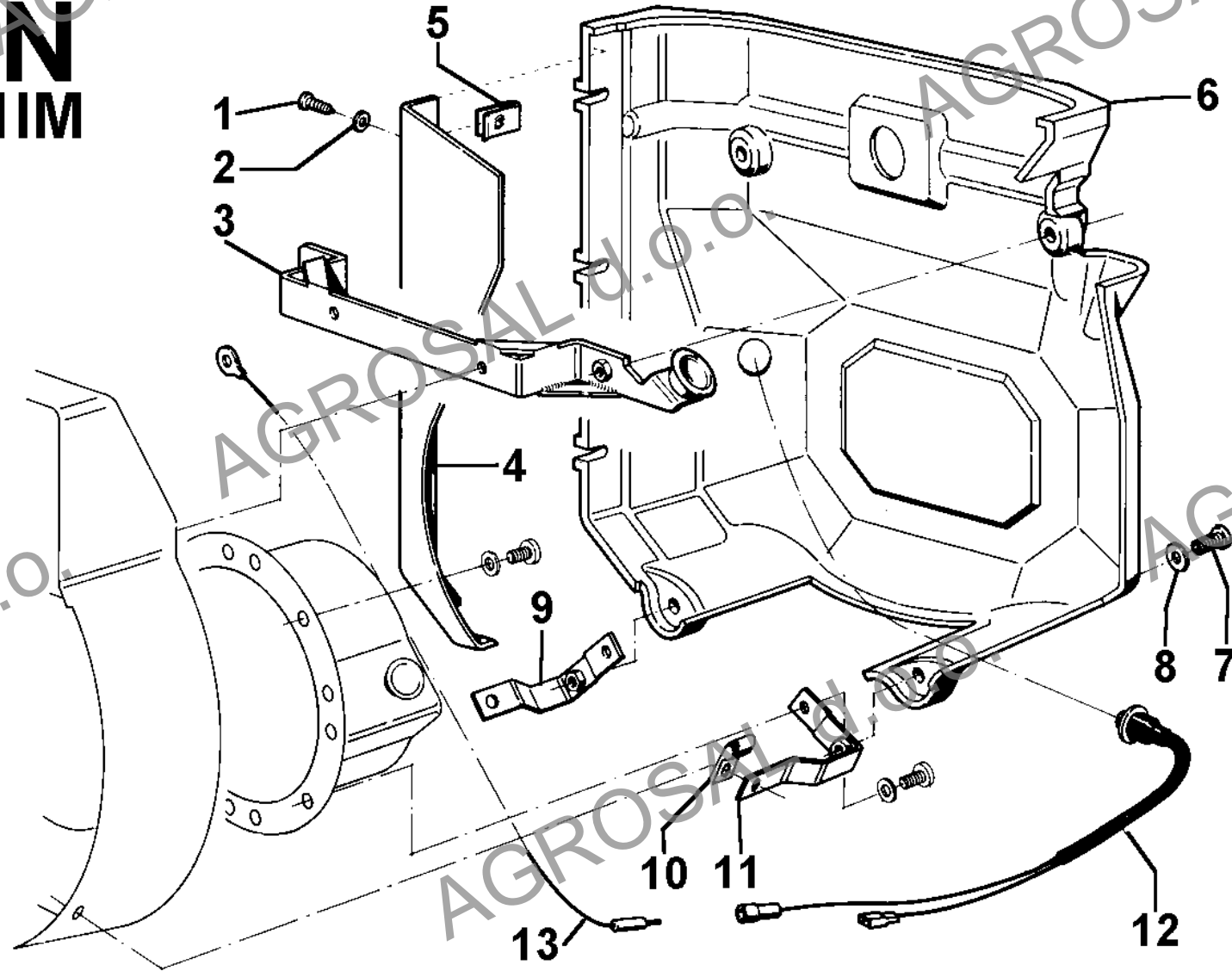

**STARTING**

POS.	CODE	DESCRIPTION	Qty
1	8140.097	spare part set	1
2	6456.009	pinion gear	1
3	<----->	plate	0
5	8310.043	brush set	1
6	<----->	support	0
10	5041.019	relay	1
11	1165.006	circlip diam. 7	1
12	3410.054	spacer	1
13	2136.022	cap	1
14	3410.054	spacer	1
15	6366.004	plate	1
16	7100.244	pulley	1
17	5801.179	rewind spring	1
18	3430.101	spacer	1
19	9790.037	screw M 6 x 8	2
20	6961.014	pulley	1
21	7555.004	washer diam. 6	4
22	1760.005	bolt M 6 x 1 x 16	4
23	5680.064	spring	1
24	<----->	spring	0
25	4055.005	rope starting	1
26	1471.069	REWIND STARTING motorcultivator	1
26	1471.085	REWIND STARTING	1
27	7625.008	washer diam. 6,4	4
28	9790.039	screw M 6 x 12	2
33	7362.228	voltage regul.12 V 12 A	1
34	7362.232	light.alt.regul.-5 contacts for alt. 3 wires	1
35	5840.119	starting motor	1



**M**  
**11M**

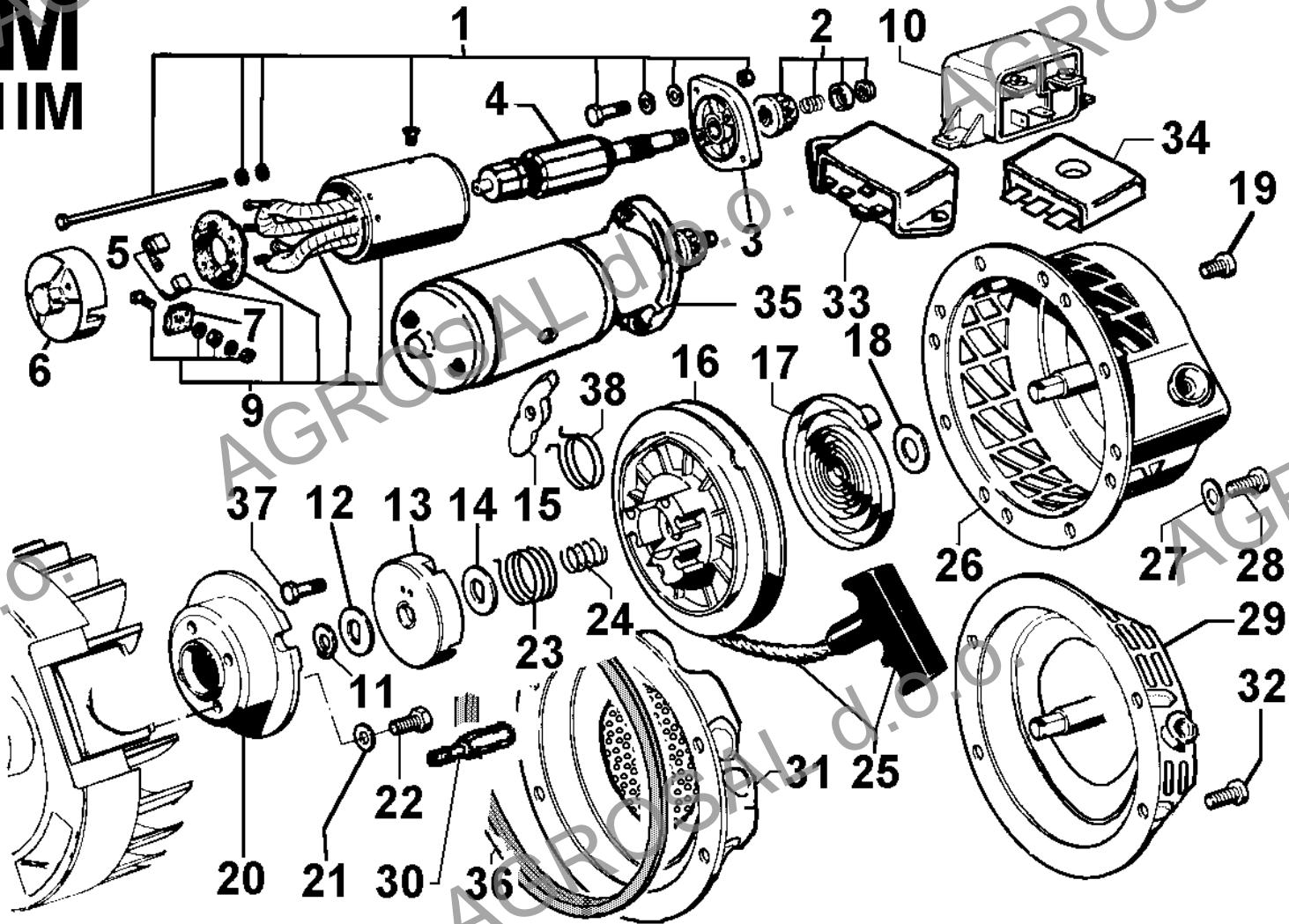

**TIMING/SPEED GOVERNOR**

POS.	CODE	DESCRIPTION	Qty
1	3240.004	nut M 5	1
2	7555.003	washer diam. 5	1
3	771R.001	washer diam. 5,3	1
4	5200.880	lever	1
5	1755.014	bolt M 5 x 25	1
6	5801.560	recovery spring	1
7	2183.031	hinge link	1
8	9685.154	exhaust valve	1
9	9652.162	intake valve	1
10	6400.029	cup	2
11	5755.125	valve spring	2
12	6400.028	cup	2
13	7215.029	tappet	2
14	771R.001	washer diam. 5,3	1
15	1919.006	bolt	1
16	<----->	see Pos.E 30	0
19	1165.010	circlip	1
20	9790.047	screw M 6 x 16	3
21	6140.415	governor pin	1
22	5204.006	lever	1
23	7555.004	washer diam. 6	1
24	3240.008	nut M 6	1
25	7200.064	drive rod	1
26	<----->	spacer	0
27	1165.010	circlip	1
28	7620.017	washer	1
29	6130.050	pin	1
30	7362.235	SPEED GOVERNOR	1
31	1301.245	anello rasam d.28,8x16x0,5	1
32	1111.106	compression shaft	1
33	8430.061	lockpin 4 x 14	1
34	3348.040	CAMSHAFT automatic compression release	1

# E 1IM

