

AGROSAL d.o.o.

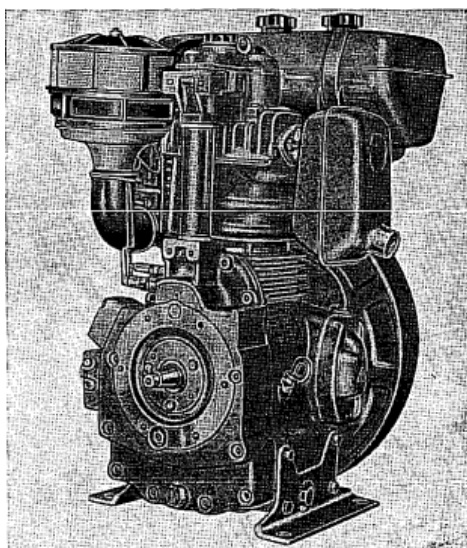

LA(P) 490



AGROSAL d.o.o.

Gregorčičeva ulica 38, 5270 Ajdovščina
telefon: 05 368 90 96, fax: 05 368 90 97
e-mail: info@agrosal.si, www.agrosal.si



RICAMBI - PIÈCES DETACHÉES - SPARE PARTS - ERSATZTEILE

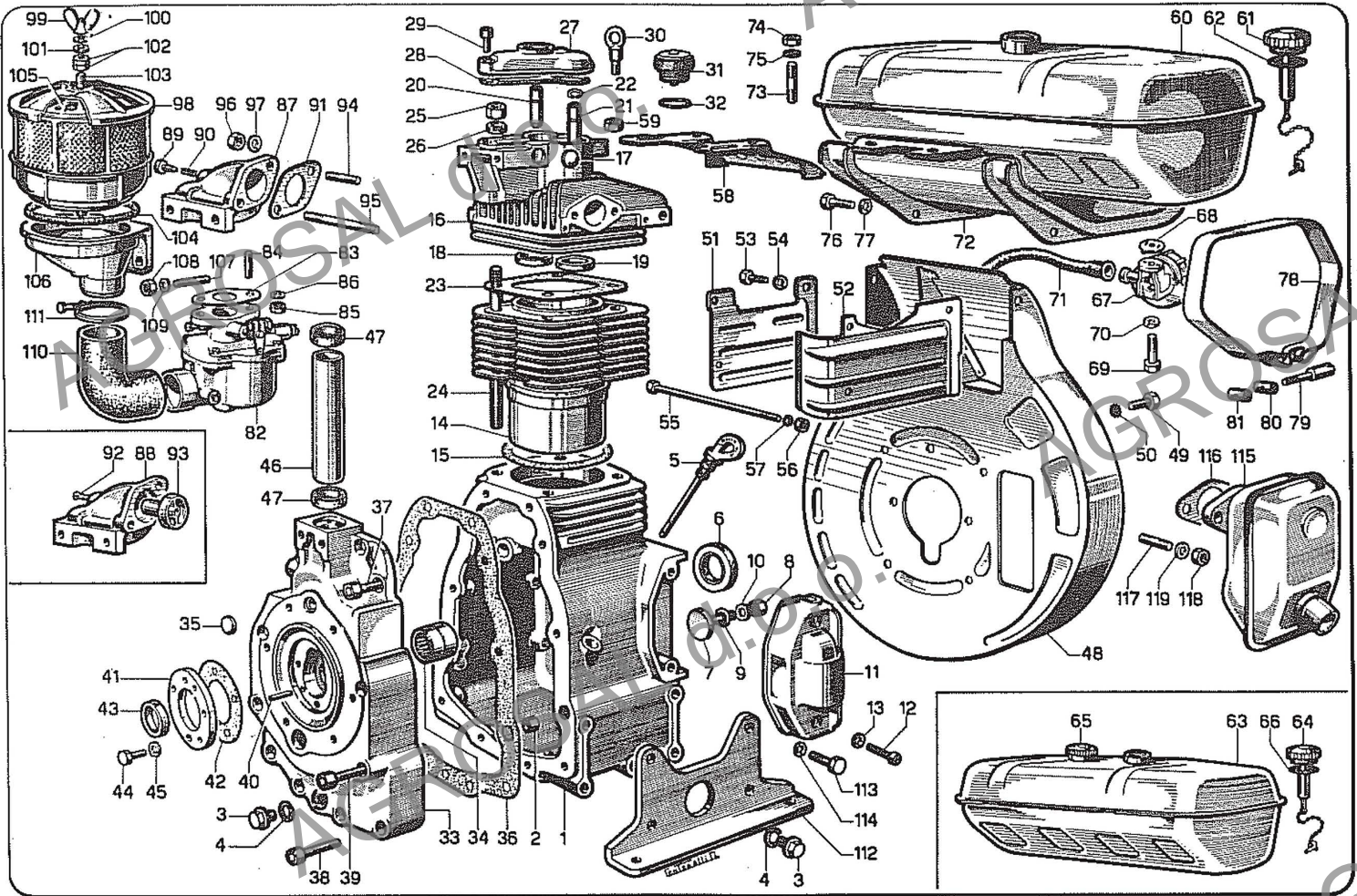

No.	Matricola Référence Part No. Teil Nr.	DENOMINAZIONE	Pezzi Pièces Stücker	DENOMINATION	DESCRIPTION	BENENNUNG
1	70-1510-47 145-1512-80	Basamento compl. 400-490 Basamento compl. 510	1 1	Carter moteur compl. 400-490 Carter moteur compl. 510	Crankcase ass.y 400-490 Crankcase ass.y 510	Kürbelgehäuse kompl. 400-490 Kürbelgehäuse kompl. 510
2	70-1970-39	Bussole	2	Douille	Sleeve	Büchse
3	70-8865-19	Tappo	2	Bouchon	Cap	Verschluss
4	1-4670-16	Guarnizione	2	Joint	Gasket	Dichtung
5	70-1400-20	Asta livello	1	Jauge niveau	Dipstick	Meßstab
6	70-1210-45	Anello tenuta	1	Bague d'étanchéité	O-ring	Dichtring
7	70-6055-20	Perno	1	Axe	Journal	Zapfen
8	1-3240-18	Dado Ø x 1,25	1	Ecrou Ø x 1,25	Nut Ø x 1,25	Mutter Ø x 1,25
9	70-1200-35	Anello OR	1	Joint torique	O-Ring	Dichtring
10	1-7565-07	Rondella	1	Washer	Washer	Unterlegscheibe
11	70-2750-03	Coperchio	1	Couvercle	Cover	Deckel
12	70-9790-28	Vite 5 x 0,8	2	Vis 5 x 0,8	Capscrew 5 x 0,8	Schraube 5 x 0,8
13	250-7555-03	Rondella	2	Rondelle	Washer	Unterlegscheibe
14	70-2380-32 69-2380-41 74-2380-33 73-2380-42 145-2380-75	Cilindro LA-LAL 400 Cilindro LAP 400 Cilindro LA 490 Cilindro LAP 490 Cilindro LA 510	3 1 1 1 1	Cylindre LA-LAL 400 Cylindre LAP 400 Cylindre LA 490 Cylindre LAP 490 Cylindre LA 510	Cylinder LA-LAL 400 Cylinder LAP 400 Cylinder LA 490 Cylinder LAP 490 Cylinder LA 510	Zylinder LA-LAL 400 Zylinder LAP 400 Zylinder LA 490 Zylinder LAP 490 Zylinder LA 510
15	70-4410-20 145-4410-33	Guarnizione 400-490 Guarnizione 510	*1 *1	Joint 400-490 Joint 510	Gasket 400-490 Gasket 510	Dichtung 400-490 Dichtung 510
16	70-9200-48 74-9200-49 70-9200-55 74-9200-56	Testa compl. 400 Testa compl. 490-510 Testa con guide e prigionieri 400 Testa con guide e prigionieri 490-510	1 1 1 1	Culasse compl. 400 Culasse compl. 490-510 Cul. avec guides et goujons 400 Cul. avec guides et goujons 490-510	Cylinder head ass.y 400 Cylinder head ass.y 490-510 Cyl. head w. guides and studs 400 Cyl. head w. guides and studs 490-510	Zylinderkopf kompl. 400 Zylinderkopf kompl. 490-510 Kopf m. Führungen u. Stiftschr. 400 Kopf m. Führ. u. Stiftschr. 490-510
17	260-8990-07	Tappo	1	Bouchon	Cap	Verschluss
18	70-8000-25 74-8000-23	Sede valvola asp. 400 Sede valvola asp. 490-510	1 1	Siège soupape adm. 400 Siège soupape adm. 490-510	Intake valve seat 400 Intake valve seat 490-510	Einflussventilsitz 400 Einflussventilsitz 490-510
19	70-0000-22 74-0000-24	Sede valvola sc. 400 Sede valvola sc. 490-510	1 1	Siège soupape échapp. 400 Siège soupape échapp. 490-510	Exhaust valve seat 400 Exhaust valve seat 490-510	Auslassventilsitz 400 Auslassventilsitz 490-510
20	70-4845-19 70-4845-38	Guida valvola aspirazione Guida valvola esp. (+ mm. 0,5)	1 1	Guide soupape adm. Guide soupape adm. (+ 0,5 mm.)	Intake valve guide Intake valve guide (+ 0,5 mm.)	Einflussventilführung Einflussventilführung (+ 0,5 mm.)
21	70-4845-21 70-4845-37	Guida valvola scarico Guida valvola scarico (+ mm. 0,5)	1 1	Guide soupape échapp. Guide soupape échapp. (+ 0,5 mm.)	Exhaust valve guide Exhaust valve guide (+ 0,5 mm.)	Auslassventilführung Auslassventilführung (+ 0,5 mm.)
22	70-1180-03	Anello	2	Bague	Ring	Ring
23	70-4730-08	Guarnizione 400	1	Joint 400	Gasket 400	Dichtung 400
24	74-4730-09	Guarnizione 490-510	1	Joint 490-510	Gasket 490-510	Dichtung 490-510
25	70-8850-55	Prigioniero 10 x 1,5	4	Goujon 10 x 1,5	Stud 10 x 1,5	Stiftschraube 10 x 1,5
26	270-3240-32 264-7530-12	Dado 10 x 1,5 Rondella	4 4	Ecrou 10 x 1,5 Rondelle	Nut 10 x 1,5 Washer	Mutter 10 x 1,5 Unterlegscheibe
27	70-2125-17	Cappello bilancieri	1	Couvercle culbuteurs	Rocker arm cover	Kipphebeldeckel
28	70-4400-06	Guarnizione	*1	Joint	Gasket	Dichtung
29	70-9730-24	Vite Ø x 1,25	1	Vis Ø x 1,25	Capscrew Ø x 1,25	Schraube Ø x 1,25
30	70-4260-05	Golfare sollevamento	1	Attache levage	Lifting eye	Aufhängeringschraube

* Non si fornisce sciolto.
Vedi serie guarnizioni.

* Non livré séparément.
Voir jeu de joints.

* Not supplied separately.
See gasket set.

* Einzeln nicht lieferbar.
Siehe Dichtungssatz.

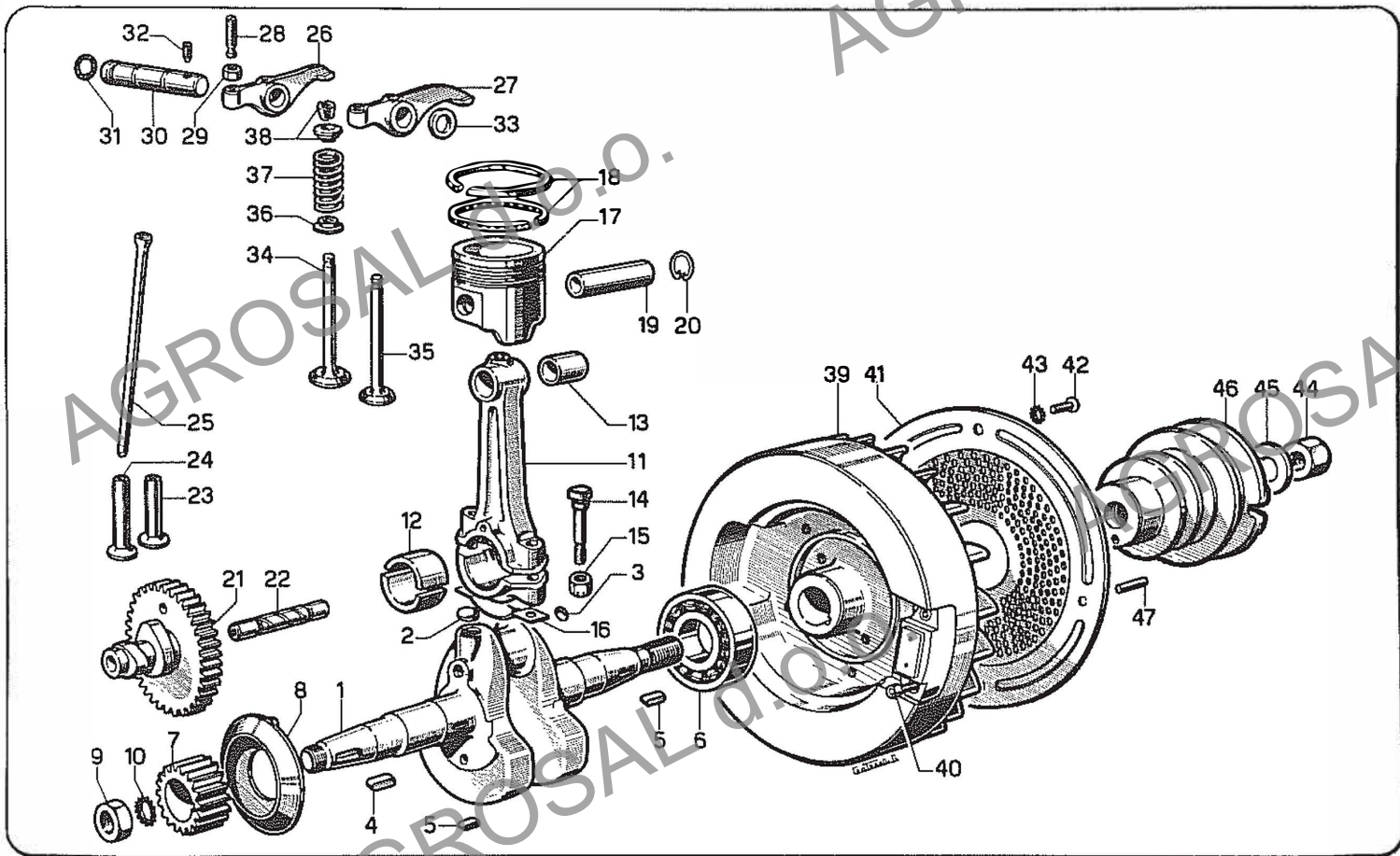

No.	Matricola Référence Part No. Teil Nr.	DENOMINAZIONE	Pezzi Pièces Stücker	DENOMINATION	DESCRIPTION	BENENNUNG
1	70-1050-49	Albero gomito compl. 400-490-510	1	Vitebreguin compl. 400-490-510	Crankshaft ass.y 400-490-510	Kurbelwelle kompl. 400-490-510
2	72-1050-50	Albero gomito compl. 400-490 sin.	1	Vitebreguin compl. 400-490 sin.	Crankshaft ass.y 400-490 sin.	Kurbelwelle kompl. 400-490 sin.
3	45-8990-05	Tappe	1	Bouchon	Cap	Verschluss
4	57-8990-02	Tappe	1	Bouchon	Cap	Verschluss
5	70-2280-46	Chivavetta	1	Clavette	Key	Keil
5	70-2280-47	Chivavetta	2	Clavette	Key	Keil
6	70-3002-58	Cuscinetto	1	Roulement	Bearing	Lager
7	70-4935-33	Ingranaggio compl.	1	Engrenage compl.	Gear ass.y	Zahnrad kompl.
8	70-2194-03	Centrifugatore olio	1	Centrifugeur d'huile	Centrifugal oil baffle	Ölschleuder
9	11-3260-14	Dado 400-490-510 16 x 1,5	1	Ecran 400-490-510 16 x 1,5	Nut 400-490-510 16 x 1,5	Mutter 400-490-510 16 x 1,5
9	53-3260-11	Dado 400-490 sin. 16 x 1,5	1	Ecran 400-490 sin. 16 x 1,5	Nut 400-490 sin. 16 x 1,5	Mutter 400-490 sin. 16 x 1,5
10	25-7540-10	Rondello	1	Rondelle	Washer	Unterlegscheibe
11	70-1525-29	Bielle compl.	1	Bielle compl.	Connecting rod ass.y	Pfeuelstange kompl.
11	70-1525-30	Bielle compl. (Bronzina — mm. 0,25)	1	Bielle compl. (cous. — 0,25 mm.)	Conn. rod ass.y (bearing — 0,25 mm.)	Pfeuelst. kompl. (Lager. — 0,25 mm.)
11	70-1525-31	Bielle compl. (Bronzina — mm. 0,50)	1	Bielle compl. (cous. — 0,50 mm.)	Conn. rod ass.y (bearing — 0,50 mm.)	Pfeuelst. kompl. (Lager. — 0,50 mm.)
12	70-1640-30	Bronzina testa biella	1	Coussinet tête de bielle	Conn. rod big end bearing	Pfeuelstangenlagerschale
12	70-1640-31	Bronzina — mm. 0,25	1	Coussinet — 0,25 mm.)	Bearing — 0,25 mm.)	Lagerschale — 0,25 mm.)
12	70-1640-32	Bronzina — mm. 0,50	1	Coussinet — 0,50 mm.)	Bearing — 0,50 mm.)	Lagerschale — 0,50 mm.)
13	70-1630-09	Bronzina piede biella	1	Coussinet pied de bielle	Conn. rod eye end bushing	Pfeuelfußbüchse
14	70-1861-15	Bullone	2	Boulon	Bolt	Bolzen
15	271-3240-17	Dado 8 x 1,25	2	Ecran 8 x 1,25	Nut 8 x 1,25	Mutter 8 x 1,25
16	70-5111-02	Lamierino	1	Arrêtoir	Retainer	Halteblech
17	70-8500-78	Pistone compl. LA 400	1	Piston compl. LA 400	Piston ass.y LA 400	Kolben kompl. LA 400
17	70-8500-79	Pistone compl. LA 400 (+ mm. 0,5)	1	Piston compl. LA 400 (+ 0,5 mm.)	Piston ass.y LA 400 (+ 0,5 mm.)	Kolben kompl. LA 400 (+ 0,5 mm.)
17	70-8500-80	Pistone compl. LA 400 (+ mm. 1)	1	Piston compl. LA 400 (+ 1 mm.)	Piston ass.y LA 400 (+ 1 mm.)	Kolben kompl. LA 400 (+ 1 mm.)
17	69-6501-01	Pistone compl. LAP-LAL 400	1	Piston compl. LAP-LAL 400	Piston ass.y LAP-LAL 400	Kolben kompl. LAP-LAL 400
17	69-6501-02	Pist. com. LAP-LAL400 (+ mm. 0,5)	1	Pist. com. LAP-LAL400 (+ 0,5 mm.)	Pist. ass.y LAP-LAL400 (+ 0,5 mm.)	Kol. komp. LAP-LAL400 (+ 0,5 mm.)
17	69-6501-03	Pist. com. LAP-LAL400 (+ mm. 1)	1	Pist. com. LAP-LAL400 (+ 1 mm.)	Pist. ass.y LAP-LAL400 (+ 1 mm.)	Kol. komp. LAP-LAL400 (+ 1 mm.)
17	74-6500-81	Pistone compl. LA 490	1	Piston compl. LA 490	Piston ass.y LA 490	Kolben kompl. LA 490
17	74-6500-82	Pistone compl. LA 490 (+ mm. 0,5)	1	Piston compl. LA 490 (+ 0,5 mm.)	Piston ass.y LA 490 (+ 0,5 mm.)	Kolben kompl. LA 490 (+ 0,5 mm.)
17	74-6500-83	Pistone compl. LA 490 (+ mm. 1)	1	Piston compl. LA 490 (+ 1 mm.)	Piston ass.y LA 490 (+ 1 mm.)	Kolben kompl. LA 490 (+ 1 mm.)
17	73-6501-04	Pistone compl. LAP 490	1	Piston compl. LAP 490	Piston ass.y LAP 490	Kolben kompl. LAP 490
17	73-6501-05	Pistone compl. LAP 490 (+ mm. 0,5)	1	Piston compl. LAP 490 (+ 0,5 mm.)	Piston ass.y LAP 490 (+ 0,5 mm.)	Kolben kompl. LAP 490 (+ 0,5 mm.)
17	73-6501-06	Pistone compl. LAP 490 (+ mm. 1)	1	Piston compl. LAP 490 (+ 1 mm.)	Piston ass.y LAP 490 (+ 1 mm.)	Kolben kompl. LAP 490 (+ 1 mm.)
17	145-8210-70	Pistone compl. LA 510	1	Piston compl. LA 510	Piston ass.y LA 510	Kolben kompl. LA 510
17	145-8210-71	Pistone compl. LA 510 (+ mm. 0,5)	1	Piston compl. LA 510 (+ 0,5 mm.)	Piston ass.y LA 510 (+ 0,5 mm.)	Kolben kompl. LA 510 (+ 0,5 mm.)
17	145-8210-72	Pistone compl. LA 510 (+ mm. 1)	1	Piston compl. LA 510 (+ 1 mm.)	Piston ass.y LA 510 (+ 1 mm.)	Kolben kompl. LA 510 (+ 1 mm.)
18	45-8210-10	Serie segmenti 400	1	Série segments 400	Piston ring set 400	Kolbenringatz 400
18	45-8210-11	Serie segm. 400 (+ mm. 0,5)	1	Série segments 400 (+ 0,5 mm.)	Piston ring set 400 (+ 0,5 mm.)	Kolbenringatz 400 (+ 0,5 mm.)
18	45-8210-12	Serie segm. 400 (+ mm. 1)	1	Série segments 400 (+ 1 mm.)	Piston ring set 400 (+ 1 mm.)	Kolbenringatz 400 (+ 1 mm.)
18	74-8210-28	Serie segmenti 490	1	Série segments 490	Piston ring set 490	Kolbenringatz 490
18	74-8210-29	Serie segm. 490 (+ mm. 0,5)	1	Série segments 490 (+ 0,5 mm.)	Piston ring set 490 (+ 0,5 mm.)	Kolbenringatz 490 (+ 0,5 mm.)
18	74-8210-30	Serie segm. 490 (+ mm. 1)	1	Série segments 490 (+ 1 mm.)	Piston ring set 490 (+ 1 mm.)	Kolbenringatz 490 (+ 1 mm.)
18	145-8210-70	Serie segmenti 510	1	Série segments 510	Piston ring set 510	Kolbenringatz 510
18	145-8210-71	Serie segm. 510 (+ mm. 0,5)	1	Série segments 510 (+ 0,5 mm.)	Piston ring set 510 (+ 0,5 mm.)	Kolbenringatz 510 (+ 0,5 mm.)
18	145-8210-72	Serie segm. 510 (+ mm. 1)	1	Série segments 510 (+ 1 mm.)	Piston ring set 510 (+ 1 mm.)	Kolbenringatz 510 (+ 1 mm.)
19	70-8480-18	Spinotto	1	Axe de piston	Piston pin	Kolbenbolzen
20	25-1260-07	Anello tenuta	2	Cliclip	Snap ring	Sicherungsring



No.	Matricola Référence Part No. Teil Nr.	DENOMINAZIONE	Pezzi Pièces Stücke	DENOMINATION	DESCRIPTION	BENENNUNG
21	70-1010-20 72-1010-19 70-1010-38 72-1010-39	Albero camme 400-490-510 Albero camme 400-490 sin. Albero camme 400-490-510 (per pompa alimentazione) Albero camme 400-490 sin. (per pompa alimentazione)	1 1 1 1	Arbre cames 400-490-510 Arbre cames 400-490 sin. Arbre cames 400-490-510 (pour pompe alim. comb.) Arbre cames 400-490 sin. (pour pompe alim. comb.)	Camshaft 400-490-510 Camshaft 400-490 sin. Camshaft 400-490-510 (for fuel feeding pump) Camshaft 400-490 sin. (for fuel feeding pump)	Nockenwelle 400-490-510 Nockenwelle 400-490 sin. Nockenwelle 400-490-510 (für Kraftstoff-Pumpe) Nockenwelle 400-490 sin. (für Kraftstoff-Pumpe)
22	70-6030-03 72-6030-04	Perno albero camme 400-490-510 Perno albero camme 400-490 sin.	1 1	Axe arbre cames 400-490-510 Axe arbre cames 400-490 sin.	Camshaft journal 400-490-510 Camshaft journal 400-490 sin.	Nockenwellenzapfen 400-490-510 Nockenwellenzapfen 400-490 sin.
23	70-7215-23	Punteria aspirazione	1	Poussoir admission	Intake tappet	Einlaßstößel
24	70-7215-22	Punteria scarico	1	Poussoir échappement	Exhaust tappet	Auslaßstößel
25	70-1410-08	Asta punteria	2	Tige poussoir	Pushrod	Stößstange
	70-4330-12 74-4330-13	Gruppo bilancieri compl. 400 Gruppo bilancieri compl. 490-510	1 1	Groupe culbuteurs compl. 400 Groupe culbuteurs compl. 490-510	Rocker arm ass.y 400 Rocker arm ass.y 490-510	Kipphebelgruppe kompl. 400 Kipphebelgruppe kompl. 490-510
26	70-1540-42	Bilanciere aspirazione compl.	1	Culbuteur admission compl.	Intake rocker arm ass.y	Einlasskippebel kompl.
27	70-1540-43	Bilanciere scarico compl.	1	Culbuteur échappement compl.	Exhaust rocker arm ass.y	Auslasskippebel kompl.
28	70-9850-36	Vite	2	Vis	Capscrew	Schraube
29	1-3240-10	Dado 7 x 1	2	Ecrou 7 x 1	Nut 7 x 1	Mutter 7 x 1
30	70-6045-15	Perno	1	Axe	Journal	Zapfen
31	70-7201-27	Anello OR	1	Joint torique	O - Ring	Dichtring
32	70-9765-51	Vite 6 x 1	1	Vis 6 x 1	Capscrew 6 x 1	Schraube 6 x 1
33	70-3512-08 74-3512-07	Distanziale 400 Distanziale 490-510	2 1	Entretoise 400 Entretoise 490-510	Spacer 400 Spacer 490-510	Distanzstück 400 Distanzstück 490-510
34	70-9852-10 74-9852-11	Valvola aspirazione 400 Valvola aspirazione 490-510	1 1	Soupape admission 400 Soupape admission 490-510	Intake valve 400 Intake valve 490-510	Einlassventil 400 Einlassventil 490-510
35	70-9885-10 74-9885-11	Valvola scarico 400 Valvola scarico 490-510	1 1	Soupape échappement 400 Soupape échappement 490-510	Exhaust valve 400 Exhaust valve 490-510	Auslassventil 400 Auslassventil 490-510
36	70-3430-43	Dischetto	2	Disque	Disc	Scheibe
37	70-5755-30	Molla valvola	2	Ressort soupape	Valve spring	Ventiltfeder
38	70-6410-19	Piattello con semiconi	2	Couplette avec demi-cônes	Retainer with half-collets	Federteller m. Kegeteilen
39	70-9880-94 72-9880-95	Volano compl. 400-490-510 Volano compl. 400-490 sin.	1 1	Volant compl. 400-490-510 Volant compl. 400-490 sin.	Flywheel ass.y 400-490-510 Flywheel ass.y 400-490 sin.	Schwungrad kompl. 400-490-510 Schwungrad kompl. 400-490 sin.
40	260-9730-26	Vite 8 x 1,25	2	Vis 8 x 1,25	Capscrew 8 x 1.25	Schraube 8 x 1,25
41	70-6095-12 69-6095-52 73-6095-56	Lamiara protezione volano LA-LAL Lamiara protezione volano LAP 400 Lamiara protezione volano LAP 490	1 1 1	Tôle protection volant LA-LAL Tôle protection volant LAP 400 Tôle protection volant LAP 490	Flywheel guard plate LA-LAL Flywheel guard plate LAP 400 Flywheel guard plate LAP 490	Schwungradschutzblech LA-LAL Schwungradschutzblech LAP 400 Schwungradschutzblech LAP 490
42	25-8810-07	Vite 6 x 1	4	Vis 6 x 1	Capscrew 6 x 1	Schraube 6 x 1
43	203-7540-04	Rondella	1	Rondelle	Washer	Unterlegscheibe
44	70-3260-56 417-3260-27	Dado 400-490-510 20 x 1,5 Dado 400-490 sin. 20 x 1,5	1 1	Ecrou 400-490-510 20 x 1,5 Ecrou 400-490 sin. 20 x 1,5	Nut 400-490-510 20 x 1.5 Nut 400-490 sin. 20 x 1.5	Mutter 400-490-510 20 x 1,5 Mutter 400-490 sin. 20 x 1,5
45	271-7625-23	Rondella	1	Rondelle	Washer	Unterlegscheibe
46	70-6960-24 72-6960-24	Puleggia avviamento 400-490-510 Puleggia avviamento 400-490 sin.	1 1	Poulie lancement 400-490-510 Poulie lancement 400-490 sin.	Starting pulley 400-490-510 Starting pulley 400-490 sin.	Anversscheibe 400-490-510 Anversscheibe 400-490 sin.
47	70-8400-20	Spina	1	Goupille élastique	Taper pin	Kegetstift

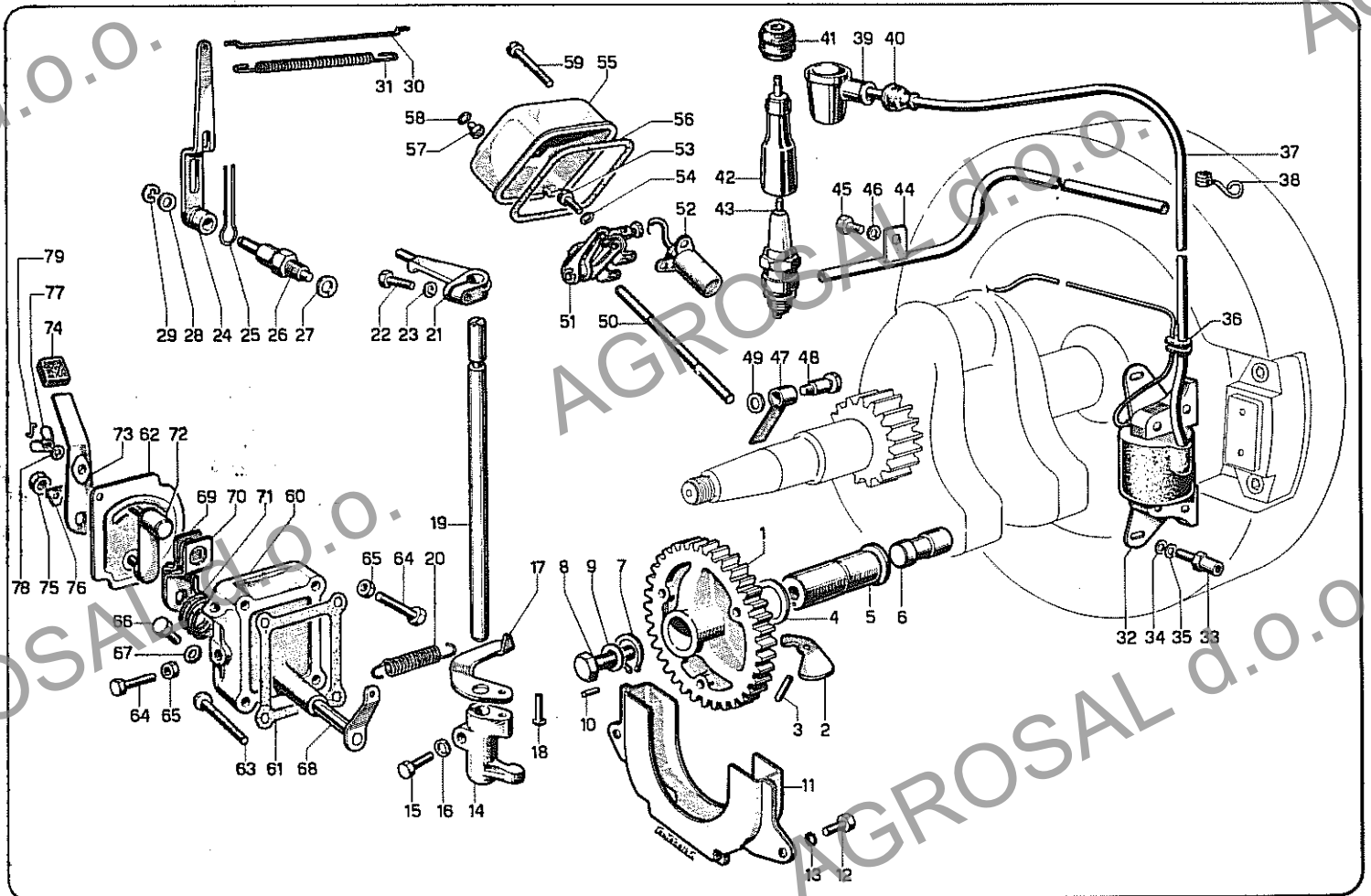



No.	Matricola Référéce Part No. Teil Nr.	DENOMINAZIONE	Pezzi Pièces Stücke	DENOMINATION	DESCRIPTION	BENENNUNG
1	70-4910-17	Ingranaggio regolatore compl.	1	Engrenage régulateur compl.	Governor gear ass.y	Reglierrad kompl.
2	70-5496-07	Massa regolatore	3	Masse régulateur	Governor weight	Fiehwegicht
3	70-6110-33	Perno	3	Axe	Journal	Zapfen
4	70-3495-35	Distanziale	2	Entretoise	Spacer	Distanzstück
5	70-6130-19	Perno regolatore	1	Axe régulateur	Governor Journal	Reglerzapfen
6	70-7200-34	Puntalino	1	Poussoir	Drive rod	Betätigungsstange
7	202-1240-16	Anello Seeger	1	Circlip	Snap ring	Sicherungsring
8	1-1770-04	Bullone 8 x 1,25	1	Boulon 8 x 1,25	Boit 8 x 1,25	Bolzen 8 x 1,25
9	260-4670-04	Guarnizione	1	Joint	Gasket	Dichtung
10	70-7770-52	Rullino	1	Aiguille	Pin	Nadel
11	70-9710-15	Vaschetta	1	Cuve	Bowl	Sumpf
12	105-1760-01	Bullone 6 x 1	2	Boulon 6 x 1	Boit 6 x 1	Bolzen 6 x 1
13	203-7540-04	Rondella	2	Rondelle	Washer	Unterlegscheibe
14	70-5270-05	Levella	1	Lévier	Lever	Hebel
15	245-1760-06	Bullone 6 x 1	1	Boulon 6 x 1	Boit 6 x 1	Bolzen 6 x 1
16	250-7555-04	Rondella	1	Rondelle	Washer	Unterlegscheibe
17	70-1450-16	Attacca	1	Attelage	Connection	Anschluss
19	70-7400-08	Ribattino	1	Rivet	Rivet	Niete
19	70-6140-52	Perno	1	Axe	Journal	Zapfen
20	70-5655-15	Molla regolatore LA-LAP	1	Ressort régulateur LA-LAP	Governor spring LA-LAP	Endregelfeder LA-LAP
	45-5655-01	Molla regolatore LAL	1	Ressort régulateur LAL	Governor spring LAL	Endregelfeder LAL
21	70-5200-21	Leva rinvio	1	Lévier renvoi	Counterlever	Umlenkhebel
22	45-1755-04	Bullone 5 x 0,8	1	Boulon 5 x 0,8	Boit 5 x 0,8	Bolzen 5 x 0,8
23	250-7555-03	Rondella	1	Rondelle	Washer	Unterlegscheibe
24	70-5200-81	Leva carburatore compl.	1	Lévier carburateur compl.	Carburetor lever ass.y	Vorgaser-Hebel kompl.
25	70-5600-12	Molla	1	Ressort	Spring	Feder
26	70-6110-27	Perno	1	Axe	Journal	Zapfen
27	5-7625-10	Rondella	1	Rondelle	Washer	Unterlegscheibe
28	70-7625-51	Rondella	1	Rondelle	Washer	Unterlegscheibe
29	246-1165-04	Anello Denzling	1	Bague d'arrêt	Washer	Unterlegscheibe
30	70-2183-25	Cavallotto	1	Etrier	Hinge link	Drahtsprengring
31	70-5800-72	Molla	1	Ressort	Spring	Bügel
32	70-1567-09	Bobina compl.	1	Bobine compl.	Coil ass.v	Zündspule kompl.
33	70-1860-83	Bullone	2	Boulon	Boit	Bolzen
34	268-7625-08	Rondella	2	Rondelle	Washer	Unterlegscheibe
35	1-7565-04	Rondella	2	Rondelle	Washer	Unterlegscheibe
36	70-5997-04	Passacable	1	Passo-cable	Wire sleeve	Kabeldurchführhülle
37	70-2190-23	Cavo compl.	1	Cable compl.	Cable ass.y	Kabel kompl.
38	70-2470-54	Collare	1	Collier	Collar	Schelle
39	25-1450-01	Attacco candela	1	Casse de bougie	Spark plug connector	Zündkerzenanschluss
40	1-5400-07	Manicotto	1	Manchon	Sheat	Hülle
41	70-2135-49	Cappellotto (Motocoltivatore)	1	Capuchon (Motoculteur)	Cap (Motor Tiller)	Schutzkappe (Einachsschlepper)
42	70-6900-37	Prolunga (Motocoltivatore)	1	Rallonge (Motoculteur)	Extension (Motor Tiller)	Verlängerung (Einachsschlepper)
43	55-2100-06	Candela LA-AL	1	Bougie LA-LAL	Spark plug LA-LAL	Zündkerze LA-LAL
	69-2100-18	Candela LAP	1	Bougie LAP	Spark plug LAP	Zündkerze LAP
44	70-9333-03	Tubo	1	Tuyau	Tube	Leitung
45	238-1760-03	Bullone 6 x 1	1	Boulon 6 x 1	Boit 6 x 1	Bolzen 6 x 1
46	1-7565-04	Rondella	1	Rondelle	Washer	Unterlegscheibe
47	70-5170-06	Lamina	1	Lamelle	Vane	Lamelle
48	70-6230-35	Perno	1	Axe	Journal	Zapfen
49	70-3525-78	Distanziale	1	Entretoise	Spacer	Distanzstück
50	70-7200-34	Puntalino	1	Poussoir	Drive rod	Betätigungsstange
51	70-5040-06	Interruttore	1	Rupteur	Breaker	Unterbrecher
52	70-2522-03	Condensatore	1	Condensateur	Condenser	Kondensator
53	70-9790-28	Vite 5 x 0,8	2	Vis 5 x 0,8	Capscrew 5 x 0,8	Schraube 5 x 0,8
54	26-7565-03	Rondella	2	Rondelle	Washer	Unterlegscheibe
55	70-2750-25	Coperchio	1	Couvercle	Cover	Deckel
56	70-4430-89	Guarnizione	1	Joint	Gasket	Dichtung
57	70-7195-03	Pulsante	1	Bouton-poussoir	Push button	Druckknopf
58	70-1260-95	Anello tenuta	1	Bague d'étanchéité	Seal ring	Dichtring
59	70-9790-29	Vite 5 x 0,8	2	Vis 5 x 0,8	Capscrew 5 x 0,8	Schraube 5 x 0,8
	70-2515-39	Comando a mano compl.	1	Commande à main compl.	Hand control ass.y	Handsteuerung kompl.
60	70-7865-17	Scatola	1	Carter	Housing	Gehäuse
61	70-4600-01	Guarnizione	1	Joint	Gasket	Dichtung
62	70-2690-53	Coperchio	1	Couvercle	Cover	Deckel
63	70-9790-30	Vite 6 x 1	4	Vis 6 x 1	Capscrew 6 x 1	Schraube 6 x 1
64	70-1760-23	Bullone 6 x 1	2	Boulon 6 x 1	Boit 6 x 1	Bolzen 6 x 1
65	105-3240-08	Dado 6 x 1	2	Ecrou 6 x 1	Nut 6 x 1	Mutter 6 x 1
66	276-1770-42	Bullone 8 x 1,25	1	Boulon 8 x 1,25	Boit 8 x 1,25	Bolzen 8 x 1,25
67	1-7625-07	Rondella	1	Rondelle	Washer	Unterlegscheibe
68	70-6140-72	Perno	1	Axe	Journal	Zapfen
69	70-6370-60	Plastrina	1	Lévier	Lever	Hebel
70	70-6370-61	Plastrina	1	Lévier	Lever	Hebel
71	70-5600-21	Molla	1	Ressort	Spring	Feder
72	70-5201-15	Leva	1	Lévier	Lever	Hebel
73	70-5201-15	Leva regolatore	1	Lévier régulateur	Governor lever	Drehzahlverstellhebel
74	270-6560-10	Pomello	1	Poignée	Knob	Griff
75	225-3240-04	Dado 5 x 0,8	1	Ecrou 5 x 0,8	Nut 5 x 0,8	Mutter 5 x 0,8
76	90-6330-57	Plastrina	1	Arrêttoir	Safety plate	Sicherungsblech
77	30-3200-01	Dado 5 x 0,8	1	Ecrou 5 x 0,8	Nut 5 x 0,8	Mutter 5 x 0,8
78	27-7625-05	Rondella	1	Rondelle	Washer	Unterlegscheibe
79	70-3695-19	Filo	1	Fil	Wire	Draht

* Non si fornisce sciolto.
Vedi serie guarnizioni.

* Non livré séparément.
Voir jeu de joints.

* Not supplied separately.
See gasket set.

* Einzeln nicht lieferbar.
Siehe Dichtungssatz.

I particolari elencati si riferiscono al motore in versione standard. Per applicazioni speciali ed accessori consultare il Catalogo Ricambi presso i Centri Assistenza e Ricambi.

Les pièces indiquées sont valables pour des moteurs standards. Pour les pièces d'adaptation et les accessoires consulter le Catalogue Pièces Détachées auprès des Agents Service.

Parts listed refer to base engine versions. Special applications or accessories are detailed on Master Parts Catalog available by Service Centers and Parts Dealers.

Die angegebenen Teile beziehen sich auf Motoren einiger Grundausführungen. Sonderanfertigungen und Zubehör sind im Ersatzteilkatalog aufgeführt. Dieser Katalog ist bei Vertragswerkstätten und Händlern einzusehen.

Descrizioni e illustrazioni non impegnative. Riserva di qualsiasi modifica per esigenze tecniche e commerciali.

Descriptions et illustrations peuvent être modifiées sans avis.

Descriptions and characteristics subject to modifications without notice.

Änderungen vorbehalten.

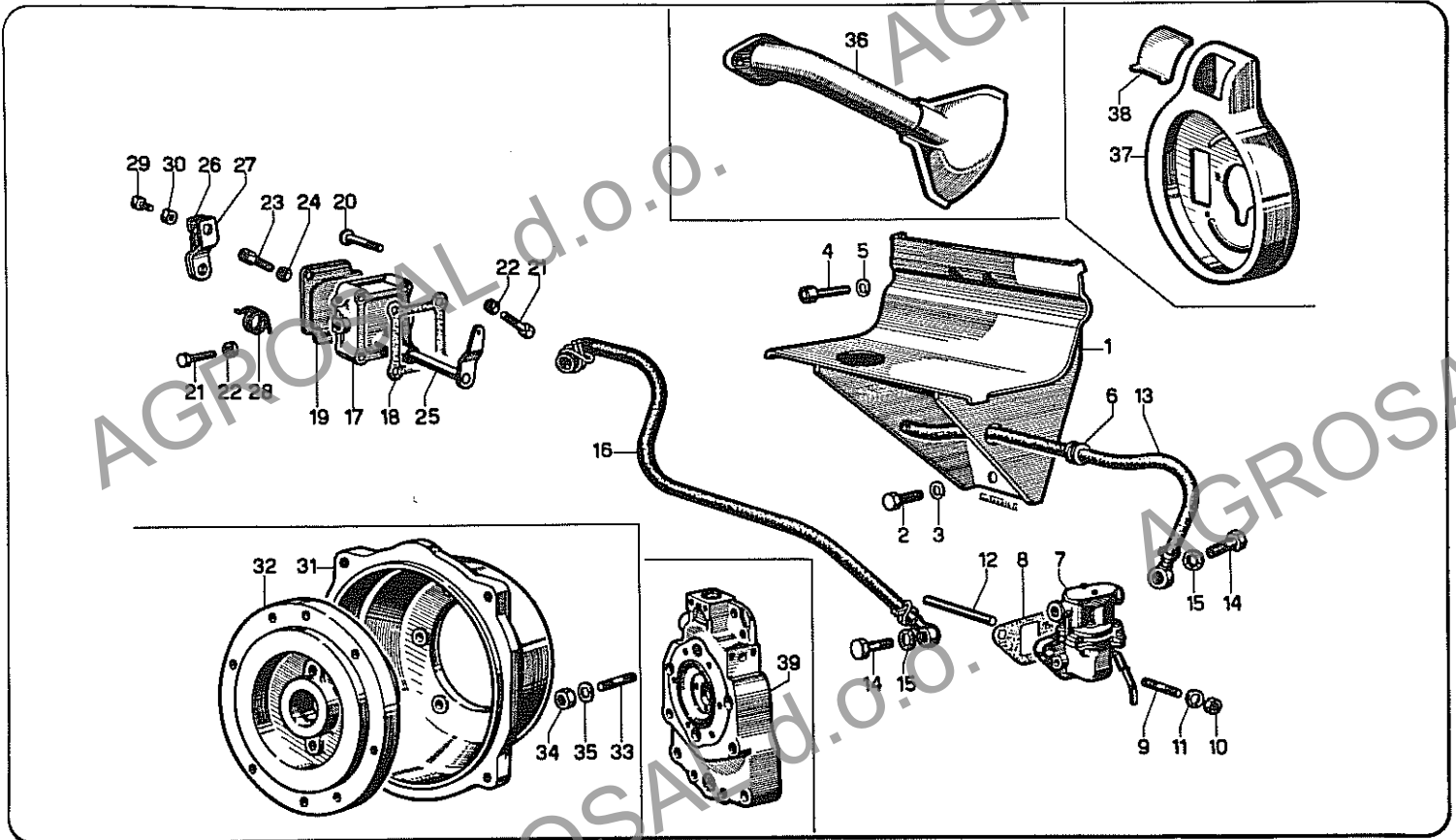

No.	Matricola Référence Part No. Teil Nr.	DENOMINAZIONE	Pezzi Pièces Pieces Stücke	DENOMINATION	DESCRIPTION	BENENNUNG
1	6525-8665-42	Supporto lato presa di moto	1	Support côté prise de force	Bracket P.T.O. side	Halter Kraftabnahme-Seite
2	70-9730-24	Vite 8 x 1,25	2	Vis 8 x 1,25	Capacrew 8 x 1,25	Schraube 8 x 1,25
3	1-7565-07	Rondella	2	Rondelle	Washer	Unterlegscheibe
4	260-9730-26	Vite 8 x 1,25	2	Vite 8 x 1,25	Capacrew 8 x 1,25	Schraube 8 x 1,25
5	1-7565-07	Rondella	2	Rondelle	Washer	Unterlegscheibe
6	6100-5997-25	Passafilo	1	Passa-cable	Wire sleeve	Kabeldurchführhülle
7	6416-8585-13	Pompa alimentazione completa	1	Pompe d'alimentation compl.	Fuel feeding pump assy	Kraftstoffpumpe kompl.
8	999-498-05	Membrana	1	Membrane	Diaphragm	Membran
9	255-4580-06	Guarnizione	*1	Joint	Gasket	Dichtung
10	260-8780-50	Prigioniero 8 x 1,25	2	Goujon 8 x 1,25	Stud 8 x 1,25	Stiftschraube 8 x 1,25
11	1-3240-18	Dado 8 x 1,25	2	Ecrou 8 x 1,25	Nut 8 x 1,25	Mutter 8 x 1,25
12	250-7555-07	Rondella	2	Rondelle	Washer	Unterlegscheibe
13	70-7200-35	Puntalino	1	Poussoir	Drive rod	Betätigungsstange
14	6416-9372-87	Tubo compl.	1	Tuyau compl.	Tube assy	Leitung kompl.
15	246-1900-08	Bullone 10 x 1	2	Boulon 10 x 1	Bolzen 10 x 1	Bolzen 10 x 1
16	246-4670-12	Guarnizione	4	Joint	Gasket	Dichtung
17	70-9372-09	Tubo combustibile compl.	1	Tubo combustible compl.	Fuel tube assy	Brennstoffleitung kompl.
18	70-2515-38	Comando a distanza compl.	1	Comm. à dist. compl.	Remote control assy	Fernsteuerung kompl.
19	70-7865-17	Scatola	1	Carter	Housing	Gehäuse
20	70-4680-01	Guarnizione	*1	Joint	Gasket	Dichtung
21	70-2690-32	Coperchio	1	Couvercle	Cover	Deckel
22	70-9790-30	Vite 6 x 1	4	Vite 6 x 1	Capacrew 6 x 1	Schraube 6 x 1
23	70-1760-23	Bullone 6 x 1	2	Boulon 6 x 1	Bolzen 6 x 1	Bolzen 6 x 1
24	105-3240-08	Dado 6 x 1	2	Ecrou 6 x 1	Nut 6 x 1	Mutter 6 x 1
25	70-9180-47	Terminale	1	Arrêt de cable	Cable end	Kabelstecker
26	3-3240-19	Dado 8 x 1,25	1	Ecrou 8 x 1,25	Nut 8 x 1,25	Mutter 8 x 1,25
27	70-6140-72	Perno	1	Axe	Journal	Zapfen
28	70-6370-60	Piastrina	1	Levier	Lever	Hebel
29	70-6370-61	Piastrina	1	Levier	Lever	Hebel
30	70-5680-21	Molla	1	Ressort	Spring	Feder
31	70-9780-23	Vite 5 x 0,8	1	Vite 5 x 0,8	Capacrew 5 x 0,8	Schraube 5 x 0,8
32	70-6000-21	Pastiglia	1	Arrêt de cable	Cable end	Kabelstecker
33	{☆}	Campana motore (autotraz.)	1	Cloche moteur (Autotraction)	Engine bell (Automotive)	Motorglocke (Fahrzeugausführ.)
34	{☆}	Campana frizione (autotraz.)	1	Cloche d'embrayage (Autotraction)	Clutch housing (Automotive)	Kupplungsglocke (Fahrzeugausführ.)
35	{☆}	Prigioniero 8 x 1,25	6	Goujon 8 x 1,25	Stud 8 x 1,25	Stiftschraube 8 x 1,25
36	{☆}	Dado	6	Ecrou	Nut	Mutter
37	{☆}	Rondella	6	Rondelle	Washer	Unterlegscheibe
38	6494-9540-80	Tubo scarico	1	Tuyau d'échappement	Exhaust pipe	Auspuffrohr
39	70-2565-56	Convogl. LA400-490-510 compl. (port.)	1	Coiffe ventil. LA 400-490-510 compl. (port.)	Shroud LA 400-490-510 assy (cover)	Haube kompl. LA 400-490-510 (Kontr. klappe)
40	72-2565-57	Convogl. LA400-490 sin. compl. (port.)	1	Coiffe ventil. LA 400-490 sin. compl. (port.)	Shroud LA 400-490 sin. assy (cover)	Haube kompl. LA 400-490 sin. (Kontr. klappe)
41	69-2565-65	Convogl. LAP400-490 compl. (partina)	1	Coiffe ventil. LAP 400-490 compl. (part.)	Shroud LAP 400-490 assy (cover)	Haube kompl. LAP 400-490 (Kontr. klappe)
42	71-2565-64	Conv. LAP400-490 sin. compl. (port.)	1	Coiffe ventil. LAP400-490 sin. compl. (port.)	Shroud LAP400-490 sin. assy (cover)	Haube kompl. LAP400-490 sin. (Kontr. klappe)
43	70-6660-20	Partina	1	Partition	Inspection cover	Gehäuse
44	70-7950-83	Scatola distribuzione completa (per pompa alimentazione)	1	Carter distribution compl. (pour pompe d'alimentation)	Gear train housing assy (for fuel feeding pump)	Steuergehäuse kompl. (für Kraftstoffpumpe)

* Non si fornisce sciolto. Vedi serie guarnizioni.

* Non livré séparément. Voir jeu de joints.

* Not supplied separately. See gasket set.

* Einzeln nicht lieferbar. Siehe Dichtungssatz.

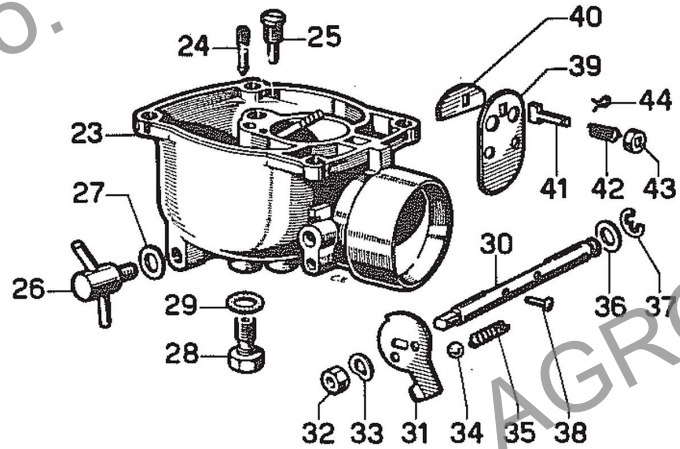
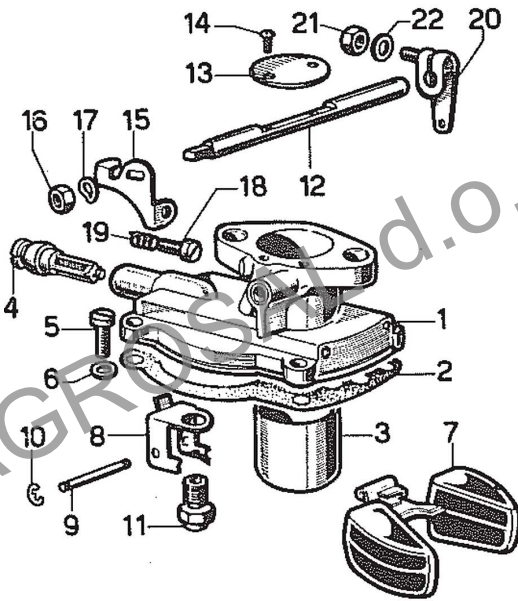

No.	Matricola Référence Part No. Teil 'Nr.	DENOMINAZIONE	Pezzi Pièces Pieces Stücke	DENOMINATION	DESCRIPTION	BENENUNG
1	999-2751-41 999-2751-47	Coperchio carburatore LA Coperchio carburatore LAP	1	Couvercle carburateur LA Couvercle carburateur LAP	Carburetor cover LA Carburetor cover LAP	Vergaserdeckel LA Vergaserdeckel LAP
2	999-4431-28	Guarnizione	1	Joint	Gasket	Dichtung
3	999-3362-11 999-3362-12 999-3362-04	Diffusore LA-LAP 400 Diffusore LAL 400 Diffusore 490-510	1	Diffuseur LA-LAP 400 Diffuseur LAL 400 Diffuseur 490-510	Diffuser LA-LAP 400 Diffuser LAL 400 Diffuser 490-510	Luftrichter LA-LAP 400 Luftrichter LAL 400 Luftrichter 490-510
4	999-3730-14	Filtro combust.	1	Filtre combust.	Fuel filter	Kraftstofffilter
5	209-9790-11	Vite 5 x 0,8	4	Vis 5 x 0,8	Cap screw 5 x 0.8	Schraube 5 x 0,8
6	27-7625-05	Rondella	4	Rondelle	Washer	Unterlegscheibe
7	999-4105-07	Galleggiante compl.	1	Flytueur compl.	Float ass.y	Schwimmer kompl.
8	999-8615-34	Supporto	1	Support	Lager	Lager
9	999-6230-66	Perno	1	Axe	Journal	Zapfen
10	999-1165-01	Anello Benzina	2	Rague d'arrêt	Circlip	Drahtsprengring
11	999-7996-08	Sede spillo compl.	1	Siège pointeau compl.	Needle valve seat ass.y	Nadelventilsiatz kompl.
12	999-1080-22 999-1080-23 999-1080-24	Albero farfalla compl. LA-LAL Albero farfalla compl. LAP 400 Albero farfalla compl. LAP 490	1	Arbre papillon compl. LA-LAL Arbre papillon compl. LAP 400 Arbre papillon compl. LAP 490	Butterfly valve shaft ass.y LA-LAL Butterfly valve shaft ass.y LAP 400 Butterfly valve shaft ass.y LAP 490	Drosselklappewelle kompl. LA-LAL Drosselklappewelle kompl. LAP 400 Drosselklappewelle kompl. LAP 490
13	999-3605-08 999-3605-15 999-3605-16	Farfalla LA-LAL Farfalla LAP 490 Farfalla LAP 400	1	Papillon LA-LAL Papillon LAP 400 Papillon LAP 490	Butterfly valve LA-LAL Butterfly valve LAP 400 Butterfly valve LAP 490	Drosselklappe LA-LAL Drosselklappe LAP 400 Drosselklappe LAP 490
14	999-9910-10	Vite 3 x 0,5	2	Vis 3 x 0,5	Cap screw 3 x 0.5	Schraube 3 x 0,5
15	999-8910-28	Squadretta regolazione compl.	1	Equerre régulateur compl.	Governor angle bracket ass.y	Regler-Winkelstück kompl.
16	225-3240-04	Dado 5 x 0,8	1	Ecrou 5 x 0,8	Nut 5 x 0.8	Mutter 5 x 0,8
17	250-7555-03	Rondella	1	Rondelle	Washer	Unterlegscheibe
18	999-9850-37	Vite	1	Vis	Cap screw	Schraube
19	999-5780-11	Molla	1	Ressort	Spring	Feder
20	999-5830-28	Morsello compl.	1	Borne de connexion compl.	Terminal connector ass.y	Anschlussklemme kompl.
21	225-3240-04	Dado 5 x 0,8	1	Ecrou 5 x 0,8	Nut 5 x 0.8	Mutter 5 x 0,8
22	27-7625-05	Rondella	1	Rondelle	Washer	Unterlegscheibe
23	999-2825-21 999-2825-22	Corpo carburatore compl. LA-LAL Corpo carburatore compl. LAP	1	Corps carburateur compl. LA-LAL Corps carburateur compl. LAP	Carburetor bowl ass.y LA-LAL Carburetor bowl ass.y LAP	Vergasergehäuse kompl. LA-LAL Vergasergehäuse kompl. LAP
24	999-4125-10 999-4125-25	Getto min. LA-LAL Getto min. LAP	1	Gicleur ralenti LA-LAL Gicleur ralenti LAP	Idle jet LA-LAL Idle jet LAP	Leerlaufdüse LA-LAL Leerlaufdüse LAP
25	999-3588-06 999-3588-03	Emulsionatore LA-LAL Emulsionatore LAP	1	Tube d'émulsion LA-LAL Tube d'émulsion LAP	Mixture tube LA-LAL Mixture tube LAP	Mischrohr LA-LAL Mischrohr LAP
26	999-9863-05	Vite scarico compl.	1	Vis de purge compl.	Drain screw ass.y	Ablass-Schraube kompl.
27	999-4370-14	Guarnizione	1	Joint	Gasket	Dichtung
28	999-4125-27 999-4125-29 999-4125-36 999-4125-28 999-4125-35 145-4125-91	Getto max. compl. LA 400 Getto max. compl. LAP 400 Getto max. compl. LAL 400 Getto max. compl. LA 490 Getto max. compl. LAP 490 Getto max. compl. LA 510	1	Gicleur maxi comp. LA 400 Gicleur maxi comp. LAP 400 Gicleur maxi comp. LAL 400 Gicleur maxi comp. LA 490 Gicleur maxi comp. LAP 490 Gicleur maxi comp. LA 510	Main jet ass.y LA 400 Main jet ass.y LAP 400 Main jet ass.y LAL 400 Main jet ass.y LA 490 Main jet ass.y LAP 490 Main jet ass.y LA 510	Hauptdüse kompl. LA 400 Hauptdüse kompl. LAP 400 Hauptdüse kompl. LAL 400 Hauptdüse kompl. LA 490 Hauptdüse kompl. LAP 490 Hauptdüse kompl. LA 510
29	200-4670-03	Guarnizione	1	Joint	Gasket	Dichtung
30	999-6100-06	Perno starter compl.	1	Axe starter compl.	Choke valve shaft ass.y	Starterklappenwelle kompl.
31	999-5195-03	Leva	1	Lever	Lever	Hebel
32	225-3240-04	Dado 5 x 0,8	1	Ecrou 5 x 0,8	Nut 5 x 0.8	Mutter 5 x 0,8
33	250-7555-03	Rondella	1	Rondelle	Washer	Unterlegscheibe
34	209-8245-03	Sfera 3/16"	1	Rouleau 3/16"	Ball 3/16"	Kugel 3/16"
35	999-5695-07	Molla	1	Ressort	Spring	Feder
36	1-7625-07	Rondella	1	Rondelle	Washer	Unterlegscheibe
37	246-1165-04	Anello Benzina	1	Bague d'arrêt	Circlip	Drahtsprengring
38	999-9910-10	Vite x 0,7	1	Vis 4 x 0,7	Cap screw 4 x 0.7	Schraube 4 x 0,7
39	999-3605-17	Farfalla aria compl.	1	Papillon starter compl.	Choke plate ass.y	Starterklappe kompl.
40	999-9700-14	Valvola	1	Soupape	Valve	Ventil
41	999-9265-34	Tirante	1	Entretolse	Tie rod	Zugstange
42	999-5755-31	Molla	1	Ressort	Spring	Feder
43	999-7980-32	Scodellino	1	Coupeille	Cup	Norb
44	270-2800-01	Copiglia	1	Goupille	Cotter pin	Spilint



intermotor s.p.a.



02100 RIETI - ITALY - Casella Postale 107 - Tel. (0746) 220.041/4 r.a. - Cable: INTERMOTOR - Telex: IMOTOR 612595 - Telefax 220.900