

# ***AGROSAL d.o.o.***



## **MD 170, 171**



***AGROSAL d.o.o.***

Gregorčičeva ulica 38, 5270 Ajdovščina  
telefon: 05 368 90 96, fax: 05 368 90 97  
e-mail: [info@agrosal.si](mailto:info@agrosal.si), [www.agrosal.si](http://www.agrosal.si)

**Catalogo parti di ricambio**  
**Spare parts catalogue**  
**Catalogue pieces de rechange**  
**Ersatzteilliste**

**MD170 MD171**



**TAVOLA/TABLE**

**1** BASAMENTO  
CRANKCASE  
CARTER MOTEUR  
KURBELGEHÄUSE

**2** MANOVELLISMO  
CRANK MECHANISM  
EQUIPAGE MOBILE  
KURBELGETRIEBE

**3** REGOLATORE GIRI  
GOVERNOR  
REGULATEUR DE TOURS  
REGLER

**4** TESTA CILINDRO  
CYLINDER HEAD - CYLINDER  
CULASSE - ZYLINDER  
ZYLINDERKOPF - ZYLINDER

**5** POMPA INIEZIONE E INIETTORE  
INJECTION PUMP AND INJECTOR  
POMPE A INJECTION-PORTE INJECTEUR  
EINSPRITZPUMPE UND EINSPRITZDÜSE

**6** RAFFREDDAMENTO  
COOLING  
REFROIDISSEMENT  
LUFTKÜHLUNG

**7** AVVIAMENTO ELETTRICO  
ELECTRICAL STARTING  
DEMARRAGE ELECTRIQUE  
ELEKTRISCHER ANLASSER

**8** ACCESSORI A RICHIESTA  
FITTINGS UPON REQUEST  
ACCESSOIRES SUR DEMANDE  
RUBEHÖRE AUF WUNSCH

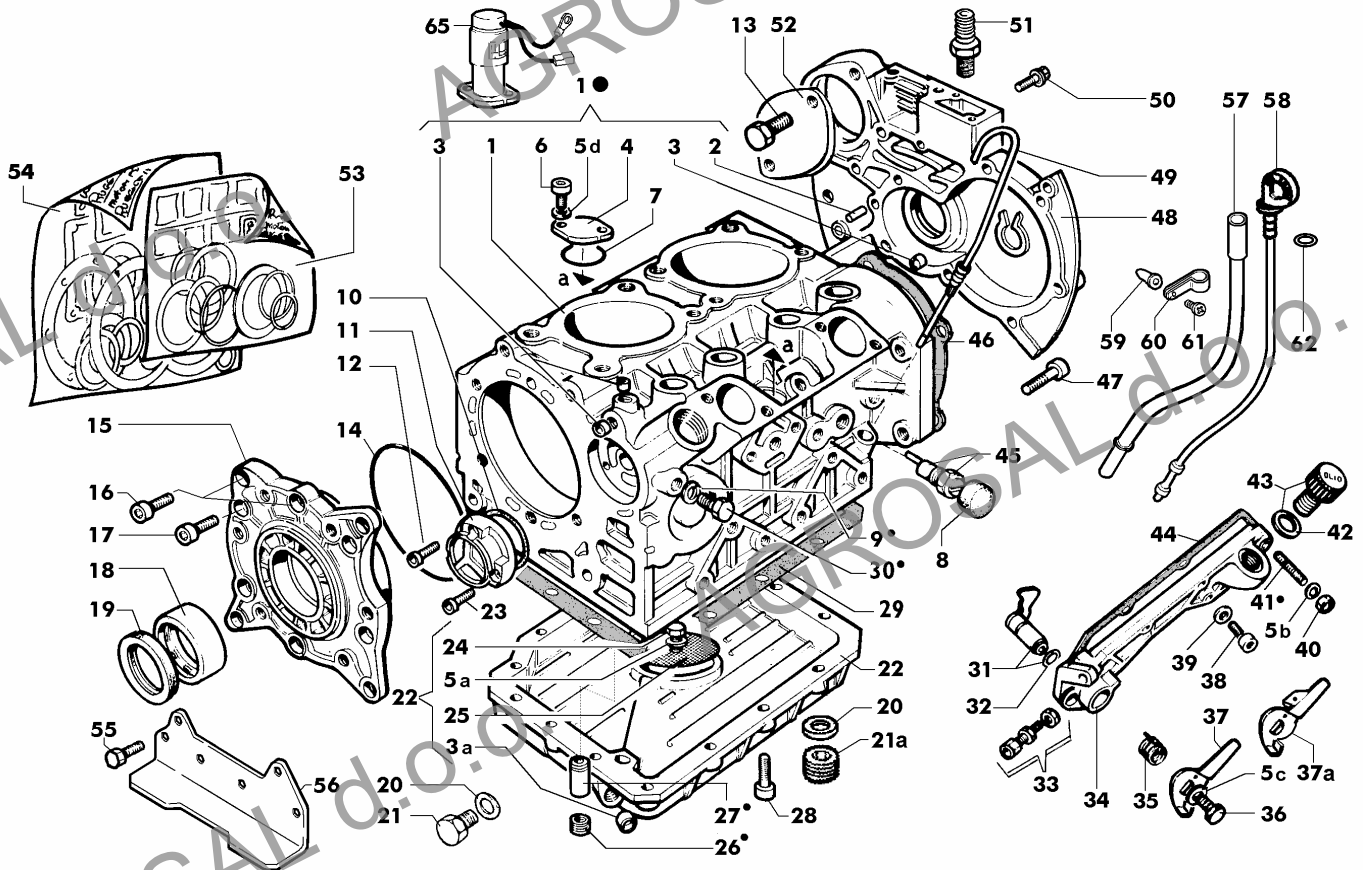

Nr. No.	CODE	MD 170 Q.ty	MD 171 Q.ty	DENOMINAZIONE - DESCRIPTION - DENOMINATION - BENENNUNG			
1	00A23R0270	1	1	Carter motore in ghisa	Crankcase	Carter Moteur	Kurbelgehäuse
2	0084001200	1	1	Spina cilindrica D.8x14	Taper pin	Goupille	Kegelstift
3	00886R0570	5	5	Tappo chiusura D.12	Plug	Bouchon	Verschluß
3a	00886R0570	1	1	Tappo chiusura D.12	Plug	Bouchon	Verschluß
4	00399R0860	1	1	Flangia	Flange	Bride	Flansch
5a	0076250080	1	1	Rondella piana D.12x6,5	Washer	Rondelle	Unterlegscheibe
5b	0076250080	1	1	Rondella piana D.12x6,5	Washer	Rondelle	Unterlegscheibe
5c	0076250080	1	1	Rondella piana D.12x6,5	Washer	Rondelle	Unterlegscheibe
5d	0076250080	2	2	Rondella piana D.12x6,5	Washer	Rondelle	Unterlegscheibe
6	0097320840	2	2	Vite M 6 x 12	Screw	Vis	Schraube
7	00579R0790	1	1	Anello OR D.33,05	O-ring	Joint torique	O-Ring
8	—	—	—	-Non disponibile-	-Not available-	-Ne pas disponible-	-Nicht vorrätig-
9	0046700580	2	2	Rondella rame D.8,2x12 sp.1	Washer	Rondelle	Unterlegscheibe
10	00579R0490	1	1	Anello OR D.41.00 sez.1,78	O-ring	Joint torique	O-Ring
11	00233R0860	1	1	Coperchio sede pompa olio	Cover	Couvercle	Deckel
12	00992R0190	1	1	Vite M.5x25	Screw	Vis	Schraube
13	0017800300	2	2	Vite TE 10x20	Screw	Vis	Schraube
14	00579R0780	1	1	Anello OR D.113,97	O-ring	Joint torique	O-Ring
15	0086753000	1	1	Supporto di banco	Support	Support	Lager
16	0097320920	2	2	Vite M 8 x 18	Screw	Vis	Schraube
17	0097301180	8	8	Vite	Screw	Vis	Schraube
18	00310R0770	1	1	Cuscinetto di banco STD	Bearing	Roulement	Lager
	00310R0800	1	1	Cuscinetto di banco -0,25 mm	Bearing	Roulement	Lager
	00310R0810	1	1	Cuscinetto di banco -0,50 mm	Bearing	Roulement	Lager
19	00A21R0250	1	1	Kit anelli tenuta olio	Oil seal	Bague étanchéité	Dichtring
20	0046700610	1	1	Guarnizione in rame d.14	Gasket	Joint	Dichtung
21	0089650050	1	1	Tappo M,14x1,5 L.15	Plug	Bouchon	Verschluß
21a	0090400120	1	1	Tappo M 14	Plug	Bouchon	Verschluß
22	00A21R0240	1	1	Coppa olio in alluminio	Oil Pan	Carter Huile	Ölwanne
23	00992R0190	2	2	Vite M.5x25	Screw	Vis	Schraube



**BASAMENTO - CRANKCASE**  
**CARTER MOTEUR - KURBELGEHÄUSE**

CATALOGO RICAMBI SPARE PARTS		
TAVOLA TABLE	1	2
DATA DATE	05/2006	

Nr. No.	CODE	MD 170 Q.ty	MD 171 Q.ty	DENOMINAZIONE - DESCRIPTION - DENOMINATION - BENENNUNG			
24	0017600010	1	1	Bullone M 6 x 1 x 10	Bolt	Boulon	Stehbolzen
25	00734R0720	1	1	Rete aspirazione coppa olio	Net	Grillage	Netz
26	00999R0200	1	1	Vite M.16x1,5x10	Screw	Vis	Schraube
27	00956R0450	1	1	Valvola by-pass	Valve	Soupape	Ventil
28	0017601380	15	15	Vite M.6x30	Screw	Vis	Schraube
29	00450R0600	1	1	Guarnizione coppa olio	Gasket	Joint	Dichtung
30	00995R0160	2	2	Vite vite M.8x1x10	Screw	Vis	Schraube
31	00494R0880	1	1	Leva stop completa	Lever	Levier	Hebel
32	00579R0010	1	1	Anello OR d.8.73 sez.1,78	O-ring	Joint torique	O-Ring
33	0091801910	1	1	Registro tendi filo	Setscrew	Vis réglage	Einstellschraube
34	00235R0050	1	1	Coperchio tirante p.iniezione completo	Cover ass.y	Couvercle complet	Komplettdeckel
	0027504220	1	1	Coperchio tirante p.iniezione	Cover	Couvercle	Deckel
35	00547R0280	1	1	Molla richiamo leva stop	Spring	Ressort	Feder
36	0017600030	1	1	Vite M.6x12	Screw	Vis	Schraube
37	00494R0860	1	1	Leva esterna stop	Lever	Levier	Hebel
37a	00491R0670	1	1	Leva esterna stop	Lever	Levier	Hebel
38	0097320780	5	5	Vite M6x25	Screw	Vis	Schraube
39	0046700580	2	2	Rondella rame D.8,2x12 sp.1	Washer	Rondelle	Unterlegscheibe
40	00323R0070	1	1	Dado M.6 h.6	Nut	Écrou	Mutter
41	0067600340	1	1	Prigioniero M.6x18 r.6/3/15	Stud	Goujon	Stiftschraube
42	00758R0390	1	1	Rondella in gomma D.22 x 27 sp.2	Washer	Rondelle	Unterlegscheibe
43	0090320950	1	1	Tappo carico olio	Threaded plug	Bouchon fileté	Verschlußschraube
44	00453R0770	1	1	Guarnizione	Gasket	Joint	Dichtung
45	00722R0240	1	1	Registro suppl.coppia	Setscrew	Vis réglage	Einstellschraube
46	0044311760	1	1	Guarnizione cop. distribuzione	Gasket	Joint	Dichtung
47	0097320640	10	10	Vite M.8 x 30	Screw	Vis	Schraube
50	00240R0450	1	1	Coperchio distribuzione	Cover	Couvercle	Deckel
49	00076R0480	1	1	Asta livello olio	Rod	Tige	Stange
50	0097320780	1	1	Vite M6x25	Screw	Vis	Schraube
51	00717R0800	1	1	Raccordo per sfiato	Union	Raccord	Anschlußstück
52	0063000210	1	1	Coperchio sede motorino avviam.	Cover	Couvercle	Deckel
53	00A22R0920	1	1	Serie guarnizioni smeriglio	Hoveraul gasket set	Joint	Dichtung
54	00A22R0910	1	1	Serie guarnizioni completa	Complete gasket set	Joint	Dichtung
55	0017700040	12	12	Vite M8	Screw	Vis	Schraube
56	00626R0030	2	2	Piede	Engine mount	Pied	Fuß
57	00940R0340	1	1	Tubo asta livello	Dipstick guard	Tube jauge niveau	Ölpeilstabrohr
58	00076R0500	1	1	Asta livello olio	Oil dipstick	Jauge huile	Meßstab
59	00742R0150	1	1	Rivetto filettato M.6	Rivet	Rivet	Niete
60	0036170880	1	1	Fascetta	Clamp	Collier	Schelle
61	0097900470	1	1	Vite M.6x16	Capscrew	Vis	Schraube
62	0012002740	1	1	Anello OR d.8,00	Oil seal	Bague en caoutchouc	O-Ring
65	00674R0470	1	1	Elettrostop 12V	Elettrostop	Elettrostop	Elettrostop
	00674R0680	1	1	Elettrostop 24V	Elettrostop	Elettrostop	Elettrostop

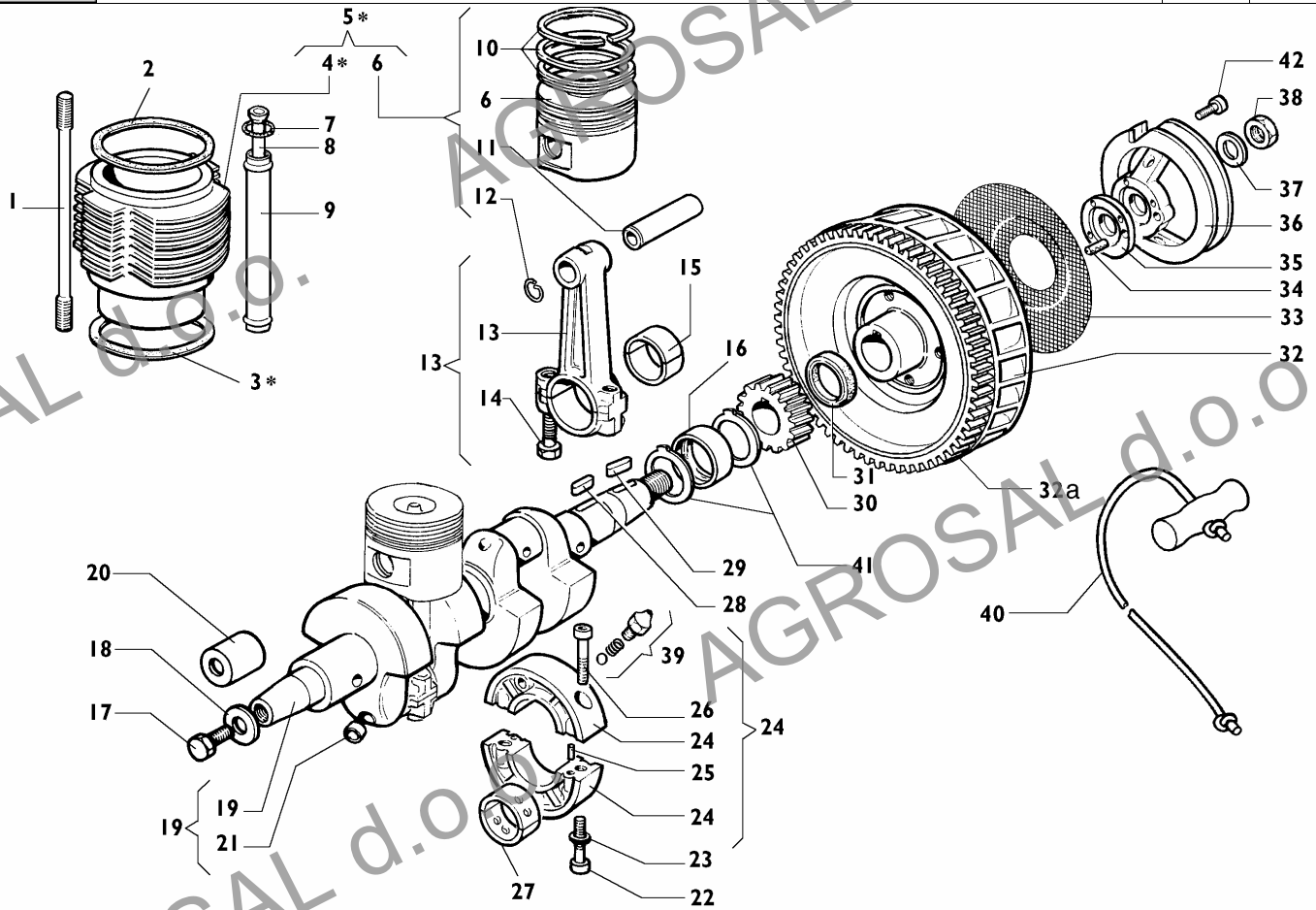

Nr. No.	CODE	MD	MD	DENOMINAZIONE - DESCRIPTION - DENOMINATION - BENENNUNG
		170 Q.ty	171 Q.ty	
1	00684R0340	8	8	Prigioniero cilindro Stud Goujon Stiftschraube
2	0047308880	2	2	Guarnizione testa 0,80 Gasket Joint Dichtung
	0047308890	2	2	Guarnizione testa 0,85 Gasket Joint Dichtung
	0047308900	2	2	Guarnizione testa 0,90 Gasket Joint Dichtung
	0047308910	2	2	Guarnizione testa 0,95 Gasket Joint Dichtung
	0047308920	2	2	Guarnizione testa 1,00 Gasket Joint Dichtung
	0047308930	2	2	Guarnizione testa 1,05 Gasket Joint Dichtung
	0047308940	2	2	Guarnizione testa 1,10 Gasket Joint Dichtung
	0047308840	2	2	Guarnizione testa 1,15 Gasket Joint Dichtung
	0047308850	2	2	Guarnizione testa 1,20 Gasket Joint Dichtung
	0047308860	2	2	Guarnizione testa 1,25 Gasket Joint Dichtung
	0047308870	2	2	Guarnizione testa 1,30 Gasket Joint Dichtung
3	—	—	—	-Non disponibile- -Not available- -Ne pas disponible- -Nicht vorrätig-
4	00203R0830	2	2	Cilindro D.85 Cylinder Cylindre Zylinder
5	00A22R0680	2	2	Kit cilindro-pistone Cylinder-piston Cylindre-piston Zylinder-kolben
6	00A22R0670	2	2	Pistone D.85 Piston Piston Kolben
7	0012000060	8	8	Anello OR 121 D.15,88 O-ring Joint torique O-Ring
8	00072R0100	4	4	Asta bilancieri completa Rod Tige Stange
9	00940R0380	4	4	Tubo custodia aste bilancieri Protection pipe Tuyau protection Schutzrohr
10	0082110090	2	2	Serie segmenti D.85 (2mm) STD Piston rings Segments Kolben ring
11	00854R0170	2	2	Spinotto ø22x64 foro 12 Piston pin Axe du piston Kolbenbolzen
12	00059R0810	4	4	Anello fermo spinotto ø25 Ring Bague Ring
13	00100R0520	2	2	Biella completa Connecting Rod Bielle Pleuelstange
14	0017701010	4	4	Bullone M 8 x 1 x 42 Bolt Boulon Stenbolzen
15	00A26R0370	2	2	Cuscinetto testa biella STD Bearing Roulement Lager
	00A26R0400	2	2	Cuscinetto testa biella -0,25 mm Bearing Roulement Lager
	00A26R0410	2	2	Cuscinetto testa biella -0,50 mm Bearing Roulement Lager
16	00310R0770	1	1	Cuscinetto di banco STD Bearing Roulement Lager
	00310R0800	1	1	Cuscinetto di banco -0,25 mm Bearing Roulement Lager
	00310R0810	1	1	Cuscinetto di banco -0,50 mm Bearing Roulement Lager



MANOVELLISMO - CRANK MECHANISM  
EQUIPAGE MOBILE - KURBELGETRIEBE

CATALOGO RICAMBI SPARE PARTS		
TAVOLA TABLE	2	2
DATA DATE	05/2006	

Nr. No.	CODE	MD 170 Q.ty	MD 171 Q.ty	DENOMINAZIONE - DESCRIPTION - DENOMINATION - BENENNUNG			
17	00993R0650	1	1	Vite M.14x1,5x40	Screw	Vis	Schraube
18	00771R0390	1	1	Rondella piana D.14,5x35 sp.3,5	Washer	Rondelle	Unterlegscheibe
19	00A23R0170	1	1	Albero a gomito completo	Crankshaft	Vilebrequin	Kurbelwelle
20	00886R0490	1	1	Tappo pretezione albero	Plug	Bouchon	Verschluß
21	0090801320	4	4	Tappo d.6	Plug	Bouchon	Verschluß
22	0097300320	2	2	Vite M.8x45	Screw	Vis	Schraube
23	0076250100	2	2	Rondella piana 8x15	Washer	Rondelle	Unterlegscheibe
24	00880R0260	1	1	Supporto di banco centrale	Support	Support	Lager
25	008400200	2	2	Spina cilindrica D.6x12	Taper pin	Goupille	Kegelstift
26	0097300310	2	2	Vite M 8 x 40	Screw	Vis	Schraube
27	00A26R0490	1	1	Cuscinetto di banco STD	Bearing	Roulement	Lager
	00A26R0500	1	1	Cuscinetto di banco -0,25 mm	Bearing	Roulement	Lager
	00A26R0510	1	1	Cuscinetto di banco -0,50 mm	Bearing	Roulement	Lager
28	00498R0230	1	1	Linguetta 6x6x12	Tab	Languette	Federkeil
29	00498R0190	1	1	Linguetta 6x6x25	Tab	Languette	Federkeil
30	00469R0640	1	1	Ingranaggio albero a gomito	Gear	Engrenage	Zahnrad
31	00A21R0250	1	1	Kit anelli tenuta olio	Oil seal	Bague étanchèité	Dichtring
32	0098813420	1	1	Volano con corona	Flyweel	Volant	Schwungrad
32a	00256R0140	1	1	Corona avviamento	Ring Gear	Couronne Démarrage	Starterkranz
33	00734R0700	1	1	Rete volano	Net	Grillage	Netz
34	00850R0010	1	1	Spina elastica D.6x30	Taper pin	Goupille	Kegelstift
35	0035150390	1	1	Distanziale puleggia	Spacer	Entretoise	Distanzstück
36	00697R0270	1	1	Puleggia avviamento D.32	Pulley	Poulie	Riemenscheibe
37	00771R0630	1	1	Rondella piana D.32,5x44 sp.2	Washer	Rondelle	Unterlegscheibe
38	00325R0840	1	1	Dado M.22x1,5 H.13	Nut	Ecrou	Mutter
40	0040550450	1	1	Fune avviamento	Starting rope	Corde	Seil
41	00060R0170	2	2	Anello di spallamento	Ring	Bague	Ring
42	0097300150	3	3	Vite M.6 x 30	Screw	Vis	Schraube

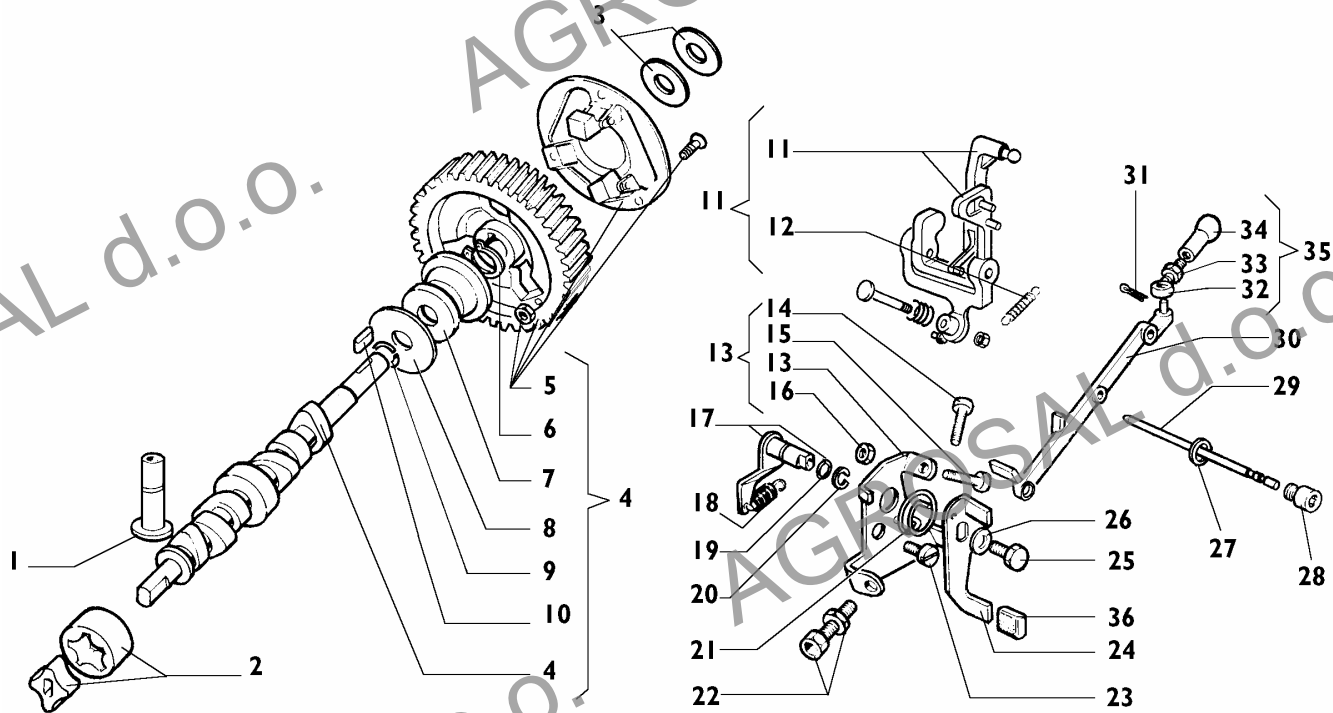

Nr. No.	CODE	MD 170 Q.ty	MD 171 Q.ty	DENOMINAZIONE - DESCRIPTION - DENOMINATION - BENENNUNG			
1	00708R0190	4	4	Punteria	Tappet	Poussoir	Stößel
2	00A21R0430	1	1	Pompa olio completa	Lub. oil pump	Pompe huile	Schmierölpumpe
3	00777R0330	1	1	Rondella rasamento 0,3 mm	Washer	Rondelle	Unterlegscheibe
	00777R0340	1	1	Rondella rasamento 0,2 mm	Washer	Rondelle	Unterlegscheibe
4	00A21R0720	1	1	Albero a camme	Camshaft	Arbre Cames	Nockenwelle
5	00469R0810	1	1	Ingranaggio albero a camme	Gear	Engrenage	Zahnrad
6	0012400130	1	1	Anello seeger	Snap ring	Circlip	Sicherungsring
7	00621R0220	1	1	Piattello regolatore	Retainer	Coupelle	Federteller
8	00777R0780	1	1	Rondella rasamento	Washer	Rondelle	Unterlegscheibe
9	00059R0850	1	1	Anello arresto	Ring	Bague	Ring
10	00498R0360	1	1	Linguetta 4x4x12	Tab	Languette	Federkeil
11	00495R0060	1	1	Leva regolatore	Lever	Levier	Hebel
12	00551R0140	1	1	Molla supplemento	Spring	Ressort	Feder
13	00613R0910	1	1	Piastrina fine corsa	Safety plate	Support	Sicherungsblech
—	—	—	—	-Non disponibile-	-Not available-	-Ne pas disponible-	-Nicht vorrätig-
—	—	—	—	-Non disponibile-	-Not available-	-Ne pas disponible-	-Nicht vorrätig-
16	0032400040	2	2	Dado M.5	Nut	Ecrou	Mutter
17	00491R0660	1	1	Leva interna acceleratore	Lever	Levier	Hebel
18	00551R0290	1	1	Molla regolatore	Spring	Ressort	Feder
19	00579R0010	1	1	Anello OR d.8.73 sez.1,78	O-ring	Joint torique	O-Ring
20	0011650360	1	1	Anello benzing D 8	Ring	Bague	Ring
21	00547R0230	1	1	Molla richiamo leva acceleratore	Spring	Ressort	Feder
22	0091801930	1	1	Registro L.20	Setscrew	Vis réglage	Einstellschraube
23	0017700010	1	1	Vite M.8x12	Screw	Vis	Schraube
24	00494R0690	1	1	Leva esterna acceleratore	Lever	Levier	Hebel
25	0017600030	1	1	Vite M.6x12	Screw	Vis	Schraube
26	0076260510	1	1	Rondella piana D.6,5x22 sp.2,5	Washer	Rondelle	Unterlegscheibe
27	0046700590	1	1	Guarnizione in rame d.10	Copper gasket	Joint en cuivre	Kupferdichtung
28	00989R0620	1	1	Vite	Screw	Vis	Schraube
29	00601R0770	1	1	Perno leva regolatore	Journal	Axe	Zapfen
30	00927R0140	1	1	Tirante collegamento pompe i.	Tie rod	Entretoise	Zugstange



REGOLATORE DI GIRI - GOVERNOR  
REGULATEUR DE TOURS - REGLER

CATALOGO RICAMBI SPARE PARTS		
TAVOLA TABLE	3	2
DATA DATE	05/2006	

Nr. No.	CODE	MD 170 Q.ty	MD 171 Q.ty	DENOMINAZIONE - DESCRIPTION - DENOMINATION - BENENNUNG			
31	00555R0370	4	4	Molla di fermo tirante pompe i.	Spring	Ressort	Feder
32	00722R0180	1	1	Registro su tirante pompe i.	Setscrew	Vis réglage	Einstellschraube
33	00323R0030	1	1	Dado M.8 H.8	Nut	Ecrou	Mutter
34	00833R0020	1	1	Snodo sferico femmina	Joint	Rotule	Gelenk
35	00927R0030	1	1	Tirante pompe Iniez. completo	Tie rod	Entretoise	Zugstange
36	0021350560	1	1	Cappello	Cap	Capuchon	Schutzkappe



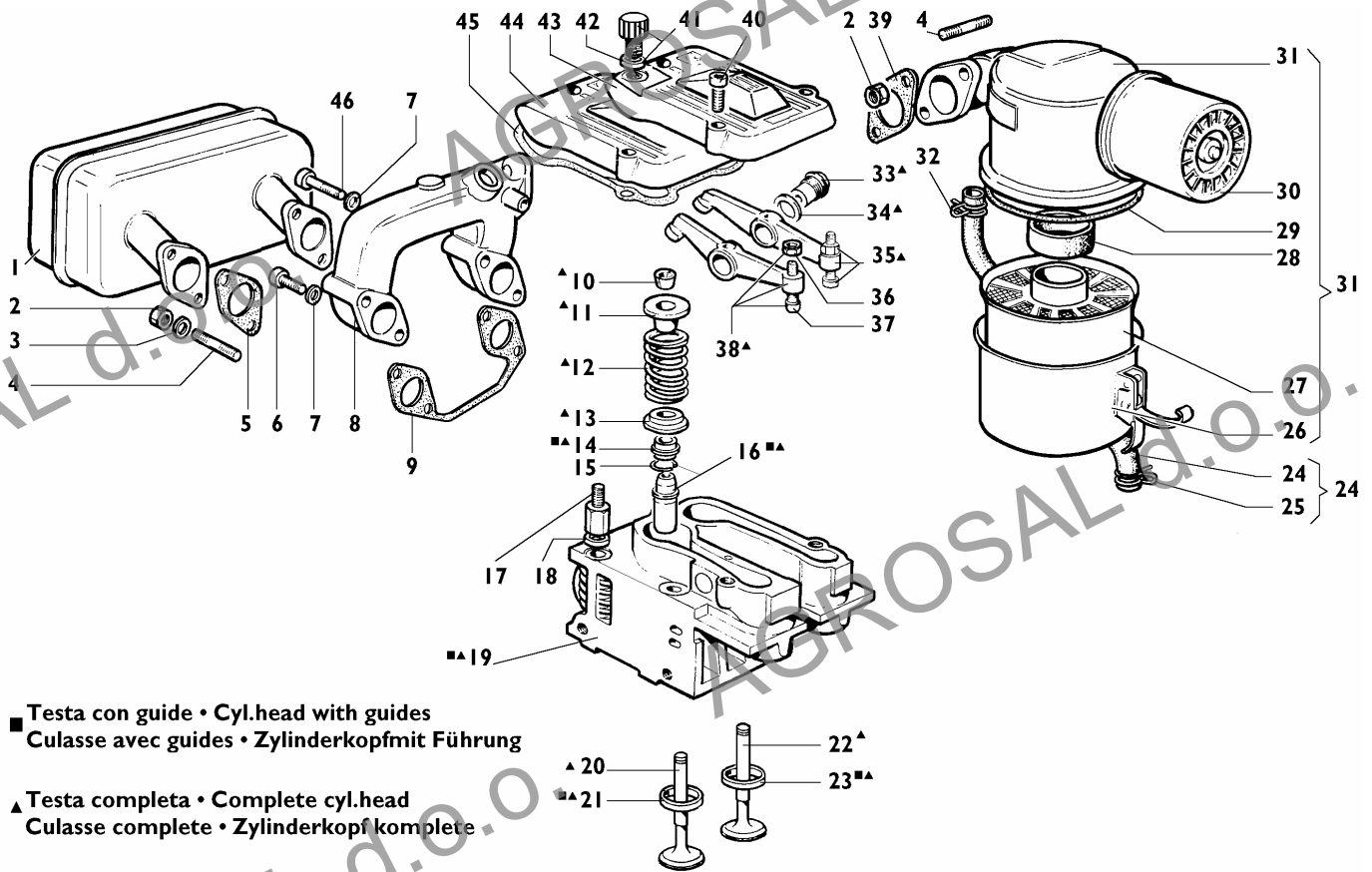

Nr. No.	CODE	MD	MD	DENOMINAZIONE - DESCRIPTION - DENOMINATION - BENENNUNG
		170 Q.ty	171 Q.ty	
1	0054620990	1	1	Marmitta Muffler Pot échappement Auspufftopf
2	0032400210	6	6	Dado speciale M.8 ch.12 Nut Ecrou Mutter
3	00763R0020	4	4	Rondella grower d.8 rinforzata Washer Rondelle Unterlegscheibe
4	0067801590	6	6	Prigioniero M.8x18 Stud Goujon Stiftschraube
5	00451R0240	2	2	Guarnizione scarico Gasket Joint Dichtung
6	0097320630	2	2	Vite M.8x35 Screw Vis Schraube
7	00771R0110	4	4	Rondella piana D.8,4x15 sp.1,5 Washer Rondelle Unterlegscheibe
8	00211R0590	1	1	Collettore aspirazione Intake Manifold Collecteur Adm. Ansaugsammelrohr
9	0044200780	2	2	Guarnizione aspirazione Gasket Joint Dichtung
10	00809R0040	8	8	Semicono Cotter Semi-cône Ventilkegelstück
11	00616R0430	4	4	Piattello superiore valvola Retainer Coupelle Federteller
12	00540R0770	4	4	Molla valvola Spring Ressort Feder
13	00616R0350	4	4	Piattello inferiore valvola Retainer Coupelle Federteller
14	0045350150	4	4	Guarnizione stelo valv.asp. Gasket Joint Dichtung
15	00059R0680	4	4	Anello guida valvola Ring Bague Ring
16	00464R0770	4	4	Guida valvola Valve Guide Guide Soupape Ventilführung
	00464R0590	4	4	Guida valvola asp/scar + 0.1 Valve Guide Guide Soupape Ventilführung
17	00326R0410	3	3	Dado testa Nut Ecrou Mutter
18	00772R0020	8	8	Rondella piana D.9,5x17 sp.4 Washer Rondelle Unterlegscheibe
19	00A22R0630	2	2	Testa motore con guide Cylinder head with guides Culasse avec guide Zylinderkopf Führung
	00919R0520	2	2	Testa motore completa Complete cylinder head Culasse complète Zylinderkopf komplette
20	00960R0590	2	2	Valvola scarico Exhaust valve Soupape échappement Auslassventil
21	00060R0040	2	2	Anello valvola scarico STD Ring Bague Ring
	00060R0280	2	2	Anello valvola scarico + 0,5 mm Snap Ring Circlip Sicherungsring
22	00960R0580	2	2	Valvola aspirazione Valve Soupape Ventil
23	00060R0030	2	2	Anello valvola aspiraz. STD Ring Bague Ring
	00060R0290	2	2	Anello valvola aspir. + 0,5 mm Snap Ring Circlip Sicherungsring
24	00949R0510	1	1	Tubo sfiato Oil pipe Tuyau huile Ölleitung
25	00375R0510	1	1	Fascetta Clamp Collier Rohrschelle
26	—	—	—	-Non disponibile- -Not available- -Ne pas disponible- -Nicht vorrätig-
27	00359R0290	1	1	Elemento filtrante Filter Element Element Filtrant Filtereinsatz



TESTA - CYLINDER HEAD  
CULASSE - ZYLINDERKOPF

CATALOGO RICAMBI SPARE PARTS		
TAVOLA TABLE	4	2
DATA DATE	05/2006	

Nr. No.	CODE	MD 170 Q.ty	MD 171 Q.ty	DENOMINAZIONE - DESCRIPTION - DENOMINATION - BENENNUNG			
28	00451R0060	1	1	Guarnizione	Gasket	Joint	Dichtung
29	00579R0730	1	1	Anello OR	O-ring	Joint torique	O-Ring
30	00670R0140	1	1	Prefiltro ciclone	Prefilter	Préfiltre	Vorfilter
31	00388R0480	1	1	Filtro aria	Air Cleaner	Filtre Air	Luftfilter
32	0036301780	1	1	Fascetta	Clamp	Collier	Rohrschelle
33	00602R0030	4	4	Perno bilancieri	Journal	Axe	Zapfen
34	00754R0340	4	4	Rondella rame D.18,2x24 sp.1	Washer	Rondelle	Unterlegscheibe
35	00104R0390	2	2	Bilanciere aspirazione	Rocker Arm	Culbuteur	Kipphebel
36	00323R0070	4	4	Dado M.6 h.6	Nut	Écrou	Mutter
37	00726R0030	4	4	Registro bilancieri	Setscrew	Vis réglage	Einstellschraube
38	00104R0400	2	2	Bilanciere scarico	Rocker Arm	Culbuteur	Kipphebel
39	00450R0350	1	1	Guarnizione asp.scarico	Gasket	Joint	Dichtung
40	0097320780	6	6	Vite M6x25	Screw	Vis	Schraube
41	0090320950	1	1	Tappo carico olio	Threaded plug	Bouchon fileté	Ver schlußschraube
42	00758R0390	1	1	Rondella in gomma D.22 x 27 sp.2	Washer	Rondelle	Unterlegscheibe
43	00233R0840	1	1	Coperchio bil.con carico olio	Cover	Couvercle	Deckel
44	00233R0820	1	1	Coperchio bilancieri	Cover	Couvercle	Deckel
45	0044000870	2	2	Guarnizione cop.bilancieri	Gasket	Joint	Dichtung
46	0097300340	2	2	Vite M.8x55	Screw	Vis	Schraube



**POMPA INIEZIONE E INIETTORE - INJECTION PUMP AND INJECTOR**  
**POMPE A INJECTION-PORTE INJECTEUR - EINSPRITZPUMPE UND EINSPRITZDÜSE**

CATALOGO RICAMBI SPARE PARTS		
TAVOLA TABLE	<b>5</b>	<b>1</b>
DATA DATE	<b>05/2006</b>	

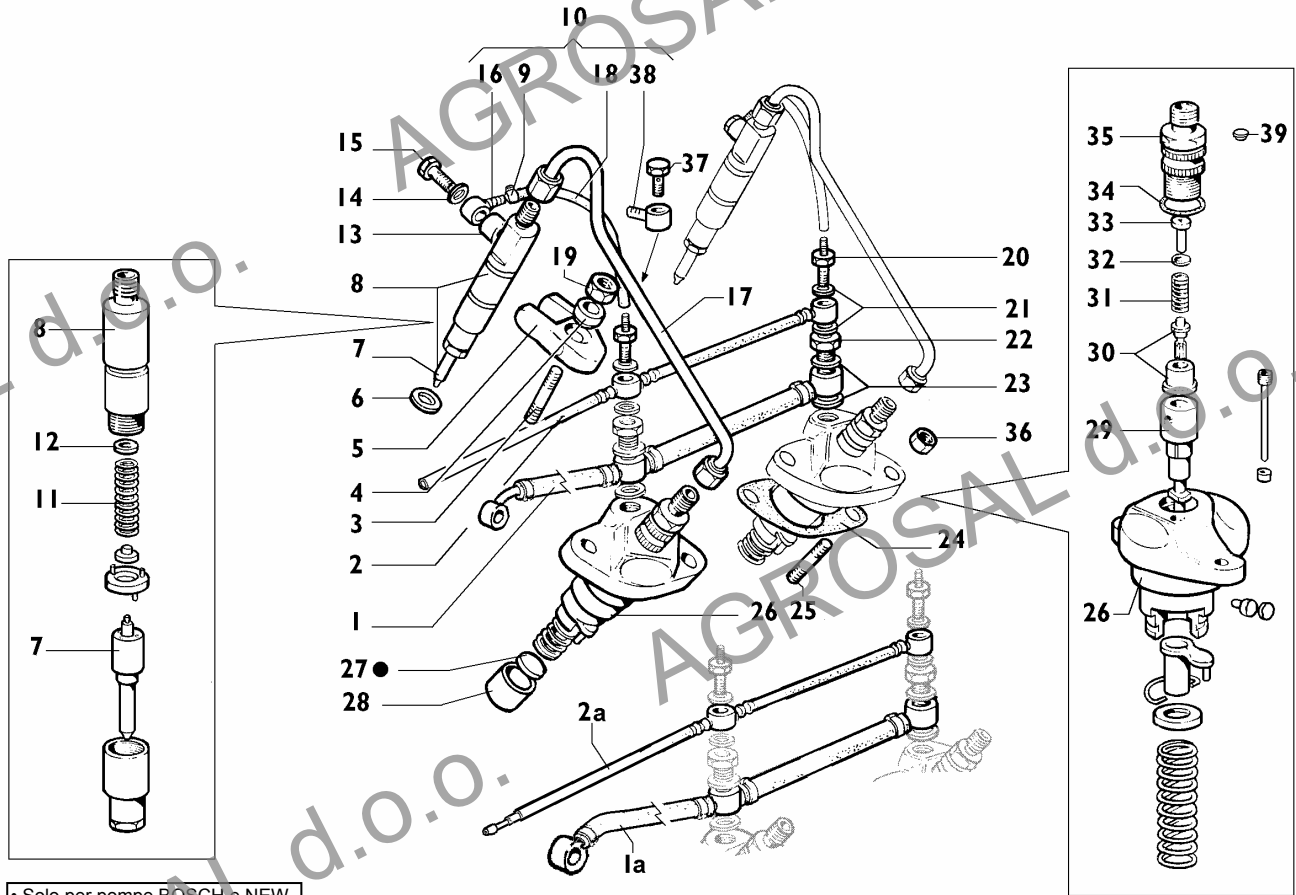

\* Solo per pompe BOSCH e NEW DIESEL

Nr. No.	CODE	MD	MD	DENOMINAZIONE - DESCRIPTION - DENOMINATION - BENENNUNG
		170 Q.ty	171 Q.ty	
1	00937R0460	1	1	Tubo nafta p.a.c. - p.iniezione Fuel pipe Tube combustible Brennstoffleitung
1a	00937R0470	1	1	Tubo filtro comb. - p.iniezione Fuel pipe Tube combustible Brennstoffleitung
2	00937R0370	1	1	Tubo disareazione p.in.-serb. Fuel pipe Tube combustible Brennstoffleitung
2a	00938R0240	1	1	Tubo disareazione p.in.-serb. Dearetion pipe Tube combustible Brennstoffleitung
3	00676R0880	2	2	Prigioniero M.8x32 r.15/12/20 Stud Goujon Stiftschraube
4	00771R0970	2	2	Rondella D.8,4x15 sp.7,5 Washer Rondelle Unterlegscheibe
5	00858R0940	2	2	Staffa iniettore Brace Etrier Bügel
6	00754R0350	2	2	Rondella rame D.7,25x21 sp.1 Washer Rondelle Unterlegscheibe
	00754R0510	2	2	Rondella rame D.7.25x21 sp.0,5 Washer Rondelle Unterlegscheibe
7	00644R0680	2	2	Polverizzatore STANADYNE Nozzle Injecteur Einspritzdüse
8	00644R0560	2	2	Polverizzatore completo BOSCH Nozzle Injecteur Einspritzdüse
	00644R0610	2	2	Polverizzatore completo STANADYNE Nozzle Injecteur Einspritzdüse
9	0036300500	4	4	Fascetta oteco clic 55 Clamp Collier Schelle
10	—	—	—	-Non disponibile- -Not available- -Ne pas disponible- -Nicht vorrätig-
11	00540R0790	2	2	Molla Spring Ressort Feder
12	00837R0300	2	2	Rondella taratura 0,1 mm Shim Cale Unterlegscheibe
	00837R0350	2	2	Spessore di taratura 1 mm Shim Cale Unterlegscheibe
13	00754R0500	2	2	Rondella rame D.6,2x10 sp.2,5 Washer Rondelle Unterlegscheibe
14	0046700620	2	2	Rondella rame D.6,2x10 sp.1,5 Washer Rondelle Unterlegscheibe
15	0072600530	2	2	Raccordo Union Raccord Anschlußstück
16	0072702370	2	2	Raccordo d. 6 Banjo union Raccord Ringanschluss
17	00944R0680	2	2	Tubo iniezione Fuel pipe Tube combustible Brennstoffleitung
18	0093759150	2	2	Tubo rifiuto iniettore Fuel pipe Tube combustible Brennstoffleitung
19	00323R0030	2	2	Dado M.8 H.8 Nut Ecrou Mutter
20	00717R0540	2	2	Raccordo disareazione Union Raccord Anschlußstück
21	0046700580	4	4	Rondella rame D.8,2x12 sp.1 Washer Rondelle Unterlegscheibe
22	0019010120	2	2	Raccordo completo disareazione Union Raccord Anschlußstück
23	0046700600	4	4	Rondella rame D.12,2x16 sp.1,5 Washer Rondelle Unterlegscheibe
24	00450R0670	2	2	Guarnizione pompa in. 0,1 mm Gasket Joint Dichtung
	00450R0660	2	2	Guarnizione pompa in. 0,2 mm Gasket Joint Dichtung
	00450R0650	2	2	Guarnizione pompa in. 0,3 mm Gasket Joint Dichtung



**POMPA INIEZIONE E INIETTORE - INJECTION PUMP AND INJECTOR**  
**POMPE A INJECTION-PORTE INJECTEUR - EINSPRITZPUMPE UND EINSPRITZDÜSE**

CATALOGO RICAMBI SPARE PARTS		
TAVOLA TABLE	<b>5</b>	<b>2</b>
DATA DATE	<b>05/2006</b>	

Nr. No.	CODE	MD	MD	DENOMINAZIONE - DESCRIPTION - DENOMINATION - BENENNUNG			
		170 Q.ty	171 Q.ty				
25	<b>0067801590</b>	4	4	Prigioniero M.8x18	Stud	Goujon	Stiftschraube
26	<b>00656R0600</b>	2	2	Pompa iniezione STANADYNE	Injection pump	Pompe injection	Einspritzpumpe
27	<b>00592R0100</b>	2	2	Pastiglia punteria NEW DIESEL	Expansion plug	Pastille	Einlegscheibe
28	<b>0072150350</b>	2	2	Punteria pompa iniezione	Tappet	Poussoir	Stößel
29	<b>00660R0240</b>	2	2	Pompante STANADYNE	Pumping element	Element pompe	Pumpenelement
	<b>00660R0220</b>	2	2	Pompante BOSCH	Pumping element	Element pompe	Pumpenelement
30	<b>00956R0430</b>	2	2	Valvola STANADYNE	Valve	Soupape	Ventil
	<b>00956R0460</b>	2	2	Valvola BOSCH	Valve	Soupape	Ventil
31	<b>0057550340</b>	2	2	Molla valvola mandata	Valve spring	Ressort soupape	Ventilfeder
32	<b>0083350290</b>	2	2	Spessore	Washer seal	Rondelle d'étanchéité	Scheibe
33	<b>0074700030</b>	2	2	Riempitore	Union	Raccord	Anschlußstück
34	<b>0012002790</b>	2	2	Anello OR d.15.60 sez.1,78	O-ring	Joint torique	O-Ring
35	<b>0072650080</b>	2	2	Raccordo	Connection	Raccord	Druckventilhalter
36	<b>0032030990</b>	4	4	Dado autobloccante M.8 H.7,9	Nut	Ecrou	Mütter
37	<b>00716R0170</b>	2	2	Raccordo 8x1x25	Union	Raccord	Anschlußstück
38	<b>00575R0300</b>	2	2	Occhiello D.8,25	Eye	Oeillet	Öse
39	<b>00738R0100</b>	2	2	Tappo per pompa	Plug	Bouchon	Verschluss



**RAFFREDDAMENTO - COOLING**  
**REFROIDISSEMENT - LUFTKÜHLUNG**

CATALOGO RICAMBI SPARE PARTS		
TAVOLA TABLE	<b>6</b>	<b>1</b>
DATA DATE	<b>05/2006</b>	

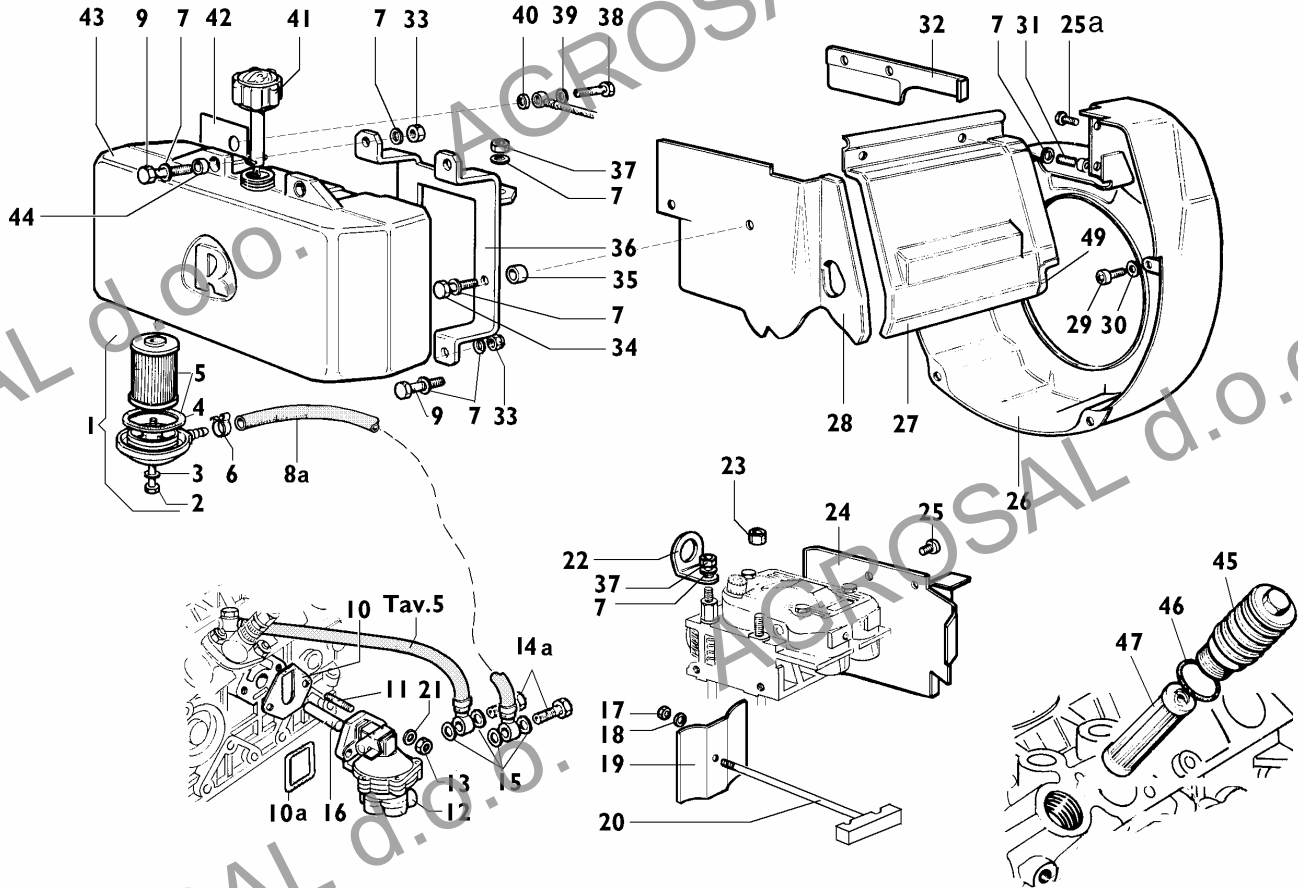

Nr. No.	CODE	MD	MD	DENOMINAZIONE - DESCRIPTION - DENOMINATION - BENENNUNG			
		170 Q.ty	171 Q.ty				
1	00391R0450	1	1	Filtro nafta interno completo	Fuel Filter	Filtre Combustible	Brennstofffilter
2	0017600610	1	1	Vite	Screw	Vis	Schraube
3	00754R0320	1	1	Rondella	Washer	Rondelle	Unterlegscheibe
4	00450R0970	1	1	Guarnizione	Gasket	Joint	Dichtung
5	0021752050	1	1	Cartuccia gasolio	Filter Element	Cartouche Filtrante	Filtereinsatz
6	0036300080	1	1	Fascetta stringitubo	Clamp	Collier	Rohrschelle
7	0076250120	19	19	Rondella	Washer	Rondelle	Unterlegscheibe
8a	00937R0320	1	1	Tubo pm.al.-ft. (mm 500)	Fuel hose	Tube combustible	Brennstoffleitung
9	0017700060	4	4	Vite M.8x25	Screw	Vis	Schraube
10	—	—	—	-Non disponibile-	-Not available-	-Ne pas disponible-	-Nicht vorrätig-
10a	0012000870	1	1	Guarnizione p.a.c.	Gasket	Joint	Dichtung
11	0067800490	2	2	Prigioniero asp. M 8 X 20 (36)	Stud	Goujon	Stehbolzen
12	0065850970	1	1	Pompa A.C.	Fuel feeding pump	Pompe d'alimentation	Kraftstoffpumpe
13	0032401640	2	2	Dado autob. M8	Nut	Ecrou	Mutter
14a	0019010300	2	2	Bullone raccordo M 10	Union bolt	Boulon raccord	Hohlschraube
15	0046700590	4	4	Guarnizione in rame d.10	Copper gasket	Joint en cuivre	Kupferdichtung
16	00704R0130	1	1	Puntalino pompa a.c.	Drive rod	Butée	Betätigungsstange
17	0032030770	1	1	Dado autobloccante M.4 H.5,8	Nut	Ecrou	Mutter
18	0076250520	1	1	Rondella piana D.4,3x9 sp.0,8	Washer	Rondelle	Unterlegscheibe
19	00589R0200	1	1	Paratia esterna cilindri	Gate	Cloison	Schott
20	00926R0780	1	1	Tirante paratie	Tie rod	Entretroise	Zugstange
21	0075550290	2	2	Rondella	Washer	Rondelle	Scheibe
22	0085060030	2	2	Golfare	Engine lifting eye	Équerre	Befestigungswinkel
23	00326R0380	5	5	Dado testa	Nut	Ecrou	Mutter
24	00588R0850	1	1	Paratia lato volante	Gate	Cloison	Schott
25	0097901380	2	2	Vite TC 6x10 5S ZN.B.	Cap screw	Vis	Schraube
25a	0097301070	2	2	Vite M.6x14	Screw	Vis	Schraube
26	0025696760	1	1	Convogliatore aria	Air conveyor	Coiffe ventil	Ventilatorhaube
27	00296R0870	1	1	Cuffia cilindri	Cylinder casing	Protection cylindre	Zylinderverkleidung
28	00588R0880	1	1	Paratia lato applicazione	Gate	Cloison	Schott
29	0097301070	2	2	Vite M.6x14	Screw	Vis	Schraube



RAFFREDDAMENTO - COOLING  
REFROIDISSEMENT - LUFTKÜHLUNG

CATALOGO RICAMBI SPARE PARTS		
TAVOLA TABLE	6	2
DATA DATE	05/2006	

Nr. No.	CODE	MD 170 Q.ty	MD 171 Q.ty	DENOMINAZIONE - DESCRIPTION - DENOMINATION - BENENNUNG			
30	0076250080	4	4	Rondella piana D.12x6,5	Washer	Rondelle	Unterlegscheibe
31	0097310920	2	2	Vite M.8x14	Screw	Vis	Schraube
32	00589R0070	1	1	Paratia superiore	Gate	Cloison	Schott
33	0032030750	4	4	Dado autobloccante M.8 H.10,4	Nut	Ecrou	Mutter
34	0017700890	2	2	Vite te M.8x30	Screw	Vis	Schraube
35	00354R0800	2	2	Distanziale per serbatoio	Spacer	Entretoise	Distanzstück
36	00879R0680	1	1	Supporto serbatoio	Support	Support	Lager
37	00323R0030	3	3	Dado M.8 H.8	Nut	Ecrou	Mutter
38	0019011730	1	1	Raccordo 8x1x25 (8.8) foro 3 mm.	Union	Raccord	Anschlußstück
39	0046700580	1	1	Rondella rame D.8,2x12 sp.1	Washer	Rondelle	Unterlegscheibe
40	00754R0460	1	1	Rondella rame D.8x14 sp.4	Washer	Rondelle	Unterlegscheibe
41	0090430980	1	1	Tappo serbatoio	Tank cap	Bouchon	Verschluss
42	00582R0960	1	1	Targhetta adesiva protez.serb.	Advert.material	Objets publicit.	Werbe-Artikel
43	0081011060	1	1	Serbatoio nafta	Fuel tank	Réservoir	Kraftstoffbehälter
44	00354R0800	4	4	Distanziale per serbatoio	Spacer	Entretoise	Distanzstück
45	00894R0550	1	1	Tappo sede filtro olio	Threaded plug	Bouchon fileté	Verschlußschraube
46	00579R0690	1	1	Anello OR D.28,30	O-ring	Joint torique	O-Ring
47	0021751950	1	1	Cartuccia filtro olio interna	Oil filter cartridge	Cartouche à huile	Ölfiltersatz

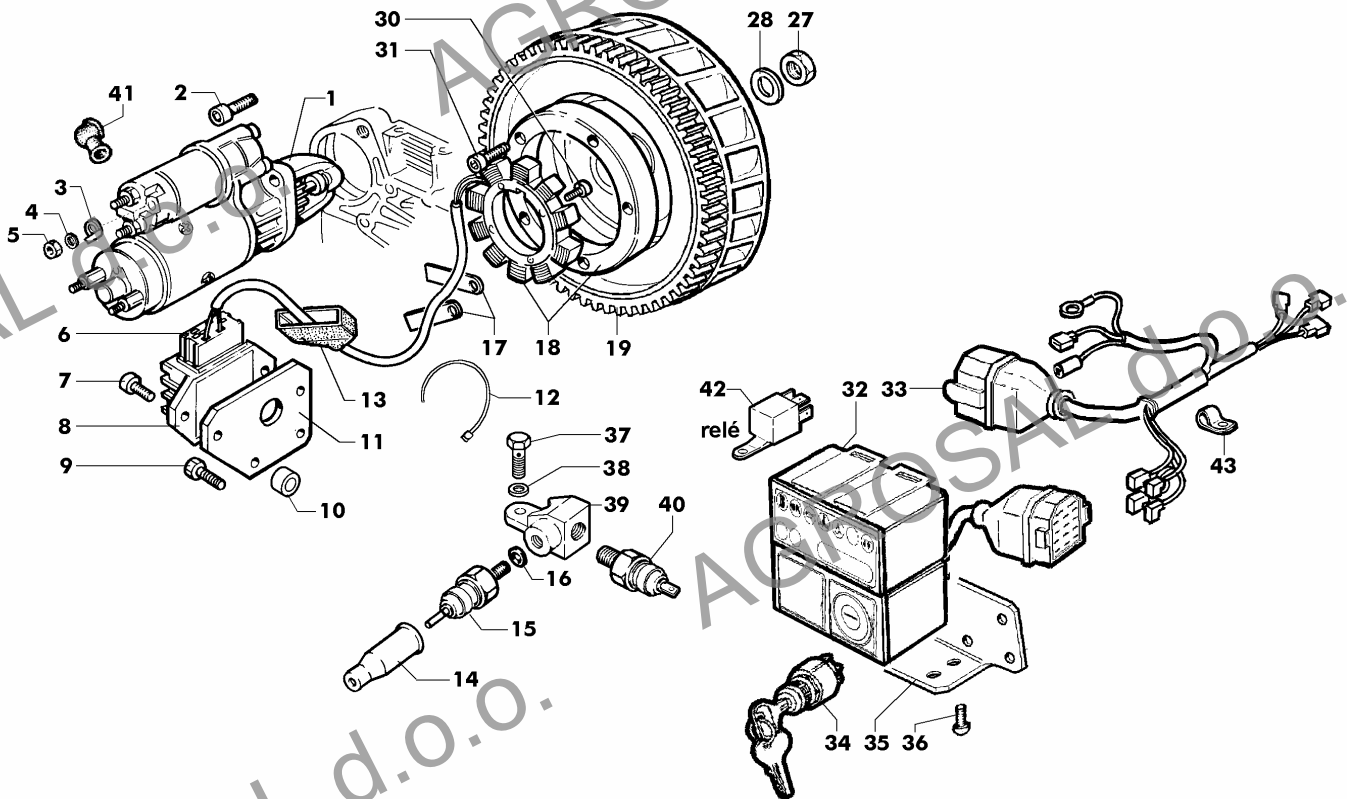

Nr. No.	CODE	MD	MD	DENOMINAZIONE - DESCRIPTION - DENOMINATION - BENENNUNG
		170 Q.ty	171 Q.ty	
1	00563R0540	1	1	Motorino avviamento BOSCH Starting motor Démarreur Anlasser
	0058402110	1	1	Motorino avviamento BOSCH 24V Starting motor Démarreur Anlasser
2	0097303690	2	2	Vite M.10x30 Screw Vis Schraube
3	0091801680	1	1	Faston Faston Faston Faston
4	00763R0020	1	1	Rondella grower d.8 rinforzata Washer Rondelle Unterlegscheibe
5	00323R0030	1	1	Dado M.8 H.8 Nut Ecrou Mutter
6	0067401530	1	1	Presa regol. Inlet regul. Prise régulateur Reglerstecker
7	0097310920	2	2	Vite M.8x14 Screw Vis Schraube
8	0073622980	1	1	Reg. tens.12V-30A - 5 cont. alt. 2 fili Voltage regulator Régulateur de tension Spannungsregler
9	0017700090	2	2	Vite vte M.8x35 Screw Vis Schraube
10	0035260970	2	2	Distanziale D.9x13 H.16 Spacer Entretoise Distanzstück
11	00613R0560	1	1	Piastrina Safety plate Support Sicherungsblech
12	0024710190	3	3	Fascetta Clamp Collier Rohrschelle
13	0021450140	1	1	Cappuccio regolatore Regulator cap Capuchon régulateur Reglerabdeckung
14	0064910130	1	1	Cappello Cap Capouchon Schutzkappe
15	00674R0010	1	1	Pressostato Elettrostop Elettrostop Elettrostop
16	0046700580	1	1	Rondella rame D.8,2x12 sp.1 Washer Rondelle Unterlegscheibe
17	00613R0760	2	2	Piastrina ferma cavo Safety plate Support Sicherungsblech
18	0011571670	1	1	Alternatore 21A Volt.alternator Alternateur Lichtmaschine
19	00256R0140	1	1	Corona avviamento Ring Gear Couronne Démarrage Starterkranz
27	00325R0840	1	1	Dado M.22x1,5 H.13 Nut Ecrou Mutter
28	00771R0460	1	1	Rondella piana D.22,2x44 sp.7,5 Washer Rondelle Unterlegscheibe
30	0097310220	4	4	Vite M.5x20 Screw Vis Schraube
31	00992R0580	5	5	Vite M.6x30 Screw Vis Schraube
32	0072454200	1	1	Quadr.12V 6 spie (con candel.)alt.3 fili Dashboard Tableau de bord Bedienfeld
33	0021861150	1	1	Cavi Cables Câbles Kabel
34	0050410200	1	1	Interruttore a chiave Key switch Interrupteur à clef Schlüsselschalter
35	0085061300	1	1	Squadretta Bracket Équerre Befestigungswinkel
36	0097303250	4	4	Vite M 5 X 10 Screw Vis Schraube
37	0019011730	1	1	Raccordo 8x1x25 (8.8) foro 3 mm. Union Raccord Anschlußstück
38	0046700580	2	2	Rondella rame D.8,2x12 sp.1 Washer Rondelle Unterlegscheibe



AVVIAMENTO ELETTRICO - ELECTRICAL STARTING  
DEMARRAGE ELECTRIQUE - ELEKTRISCHER ANLASSER

CATALOGO RICAMBI SPARE PARTS		
TAVOLA TABLE	7	2
DATA DATE	05/2006	

Nr. No.	CODE	MD 170 Q.ty	MD 171 Q.ty	DENOMINAZIONE - DESCRIPTION - DENOMINATION - BENENNUNG			
39	0073303690	1	1	Raccordo	Union	Raccord	Anschluss
40	0050412670	1	1	Interruttore pressione olio (M 10)	Oil switch	Interruteur pression	Druckschalter
41	0064910050	1	1	Pipetta mot.avv.	Pipe elbow	Pipe démarreur	Schlauchbogen
42	0073692090	1	1	Rele-centralina cand.	Preheating plug control box	Relais-boîte bougies	Relais
43	0036170200	1	1	Fascetta	Clamp	Collier	Schelle





ACCESSORI A RICHIESTA - FITTINGS UPON REQUEST  
 ACCESSOIRES SUR DEMANDE - RUBEHÖRE AUF WUNSCH

CATALOGO RICAMBI SPARE PARTS		
TAVOLA TABLE	8	1
DATA DATE	05/2006	

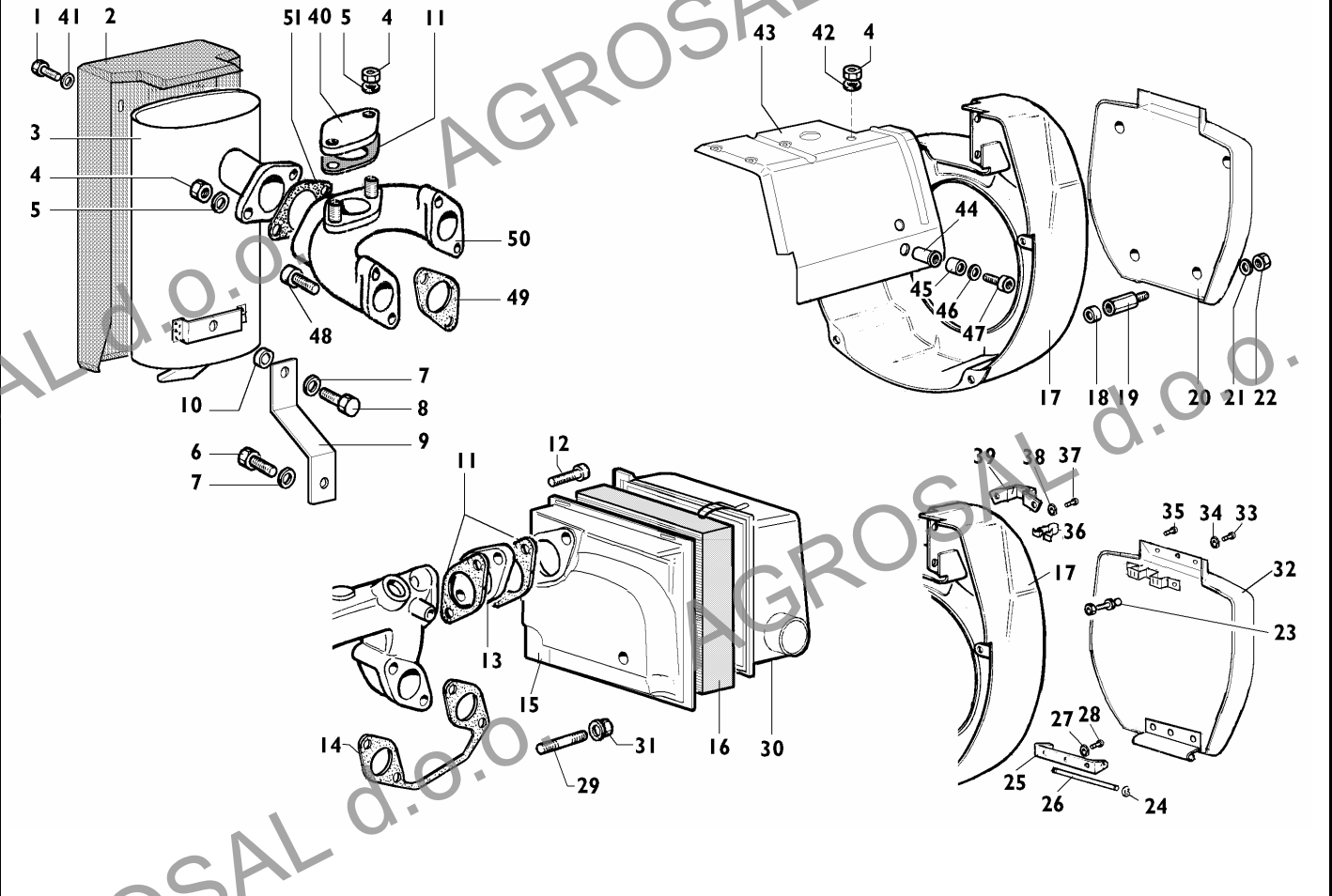

Nr. No.	CODE	MD	MD	DENOMINAZIONE - DESCRIPTION - DENOMINATION - BENENNUNG			
		170 Q.ty	171 Q.ty				
1	0017600010	4	4	Bullone M 6 x 1 x 10	Bolt	Boulon	Stenbolzen
2	00688R0620	1	1	Protezione marmitta	Guard	Protection	Schutz
3	00527R0970	1	1	Marmitta insonorizzata	Muffler	Pot Echappement	Auspufftopf
4	00323R0030	8	8	Dado M.8 H.8	Nut	Ecrou	Mutter
5	00763R0020	4	4	Rondella grower d.8 rinforzata	Washer	Rondelle	Unterlegscheibe
6	0017700060	1	1	Vite M.8x25	Screw	Vis	Schraube
7	0076250120	2	2	Rondella	Washer	Rondelle	Unterlegscheibe
8	0017700040	1	1	Vite M8	Screw	Vis	Schraube
9	00859R0620	1	1	Staffa supp. marmitta	Brace	Etrier	Bügel
10	00354R0240	1	1	Distanziale D.8,5x20 H.7	Spacer	Entretoise	Distanzstück
11	00450R0350	1	1	Guarnizione asp. scarico	Gasket	Joint	Dichtung
12	0097320640	2	2	Vite M.8 x 30	Screw	Vis	Schraube
13	0037811400	1	1	Flangia	Flange	Bride	Flansch
14	0044200780	1	1	Guarnizione aspirazione	Gasket	Joint	Dichtung
15	00268R0290	1	1	Corpo filtro aria	Filter housing	Filtre Air	Luftfilter
16	0021752440	1	1	Cartuccia filtro aria	Filter Element	Cartouche Filtrante	Filtereinsatz
17	0025696770	1	1	Convogliatore STD	Shroud	Coiffe Ventil	Ventilatorhaube
18	00354R0020	4	4	Distanziale D.8,5x13 H.5	Spacer	Entretoise	Distanzstück
19	00326R0430	4	4	Dado prolunga M.6 H.43	Nut	Ecrou	Mutter
20	00171R0540	1	1	Copripuleggia fisso	Pulley guard	Protège poulie	Riemenscheibenschutz
21	0076250700	4	4	Rondella piana D.6,5x16 sp.1,5	Washer	Rondelle	Unterlegscheibe
22	0032030210	4	4	Dado autobloccante M.6 H.7,6	Nut	Ecrou	Mutter
23	00601R0730	1	1	Perno x attacco rapido	Journal	Axe	Zapfen
24	0011650040	2	2	Anello seeger D.5	Snap ring	Circlip	Sicherungsring
25	00879R0880	1	1	Supporto copripuleggia	Support	Support	Lager
26	00601R0530	1	1	Perno supporto copripuleggia	Journal	Axe	Zapfen
27	00772R0430	5	5	Rondella piana D.3,2x8 sp.0,8	Washer	Rondelle	Unterlegscheibe
28	00738R0110	5	5	Ribattino D.3x8	Rivet	Rivet	Niete
29	0067800190	2	2	Prigioniero M.8 x 30	Stud	Goujon	Stiftschraube
30	0026051100	1	1	Coperchio filtro aria	Cover	Couvercle	Deckel
31	0032401650	1	1	Dado M.8	Nut	Ecrou	Mutter



ACCESSORI A RICHIESTA - FITTINGS UPON REQUEST  
ACCESSOIRES SUR DEMANDE - RUBEHÖRE AUF WUNSCH

CATALOGO RICAMBI SPARE PARTS		
TAVOLA TABLE	8	2
DATA DATE	05/2006	

Nr. No.	CODE	MD 170 Q.ty	MD 171 Q.ty	DENOMINAZIONE - DESCRIPTION - DENOMINATION - BENENNUNG			
32	0026700510	1	1	Copripuleggia apribile	Pulley guard	Protège poulie	Riemenscheibenschutz
33	00742R0180	3	3	Rivetto a strappo	Rivet	Rivet	Niete
34	00772R0360	3	3	Rondella piana d.4x12,5 sp.1,6	Washer	Rondelle	Unterlegscheibe
35	00738R0110	2	2	Ribattino D.3x8	Rivet	Rivet	Niete
36	00555R0320	1	1	Molla copripuleggia	Spring	Ressort	Feder
37	00738R0110	2	2	Ribattino D.3x8	Rivet	Rivet	Niete
38	00772R0430	2	2	Rondella piana D.3,2x8 sp.0,8	Washer	Rondelle	Unterlegscheibe
39	00613R0170	1	1	Piastrina	Safety plate	Support	Sicherungsblech
40	00399R0750	1	1	Flangia chiusura	Flange	Bride	Flansch
41	0076250510	4	4	Rondella piana D.6,6x18 sp.2	Washer	Rondelle	Unterlegscheibe
42	0076250120	4	4	Rondella	Washer	Rondelle	Unterlegscheibe
43	00234R0120	1	1	Coperchio motore	Cover	Couvercle	Deckel
44	00742R0150	1	1	Rivetto filettato M.6	Rivet	Rivet	Niete
45	0035251170	1	1	Distanziale D.6,5x16 H.11	Spacer	Entretoise	Distanzstück
46	0076260510	1	1	Rondella piana D.6,5x22 sp.2,5	Washer	Rondelle	Unterlegscheibe
47	0017601380	1	1	Vite M.6x30	Screw	Vis	Schraube
48	0097300310	4	4	Vite M 8 x 40	Screw	Vis	Schraube
49	00451R0240	2	2	Guarnizione scarico	Gasket	Joint	Dichtung
50	00215R0480	1	1	Collettore scarico	Exhaust Manifold	Collecteur Ech.	Auspuffsammelrohr
51	00448R0140	1	1	Guarnizione	Gasket	Joint	Dichtung



ACCESSORI A RICHIESTA - FITTINGS UPON REQUEST  
ACCESSOIRES SUR DEMANDE - RUBEHÖRE AUF WUNSCH

CATALOGO RICAMBI SPARE PARTS		
TAVOLA TABLE	8	3
DATA DATE	05/2006	

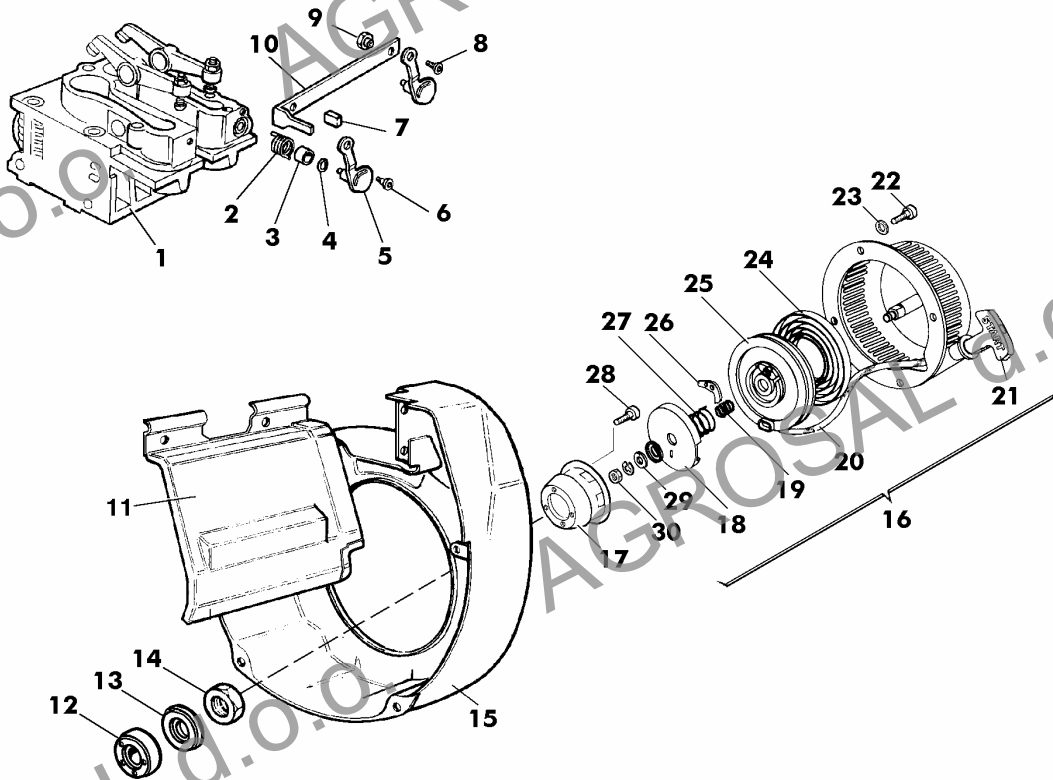

Nr. No.	CODE	MD	MD	DENOMINAZIONE - DESCRIPTION - DENOMINATION - BENENNUNG
		170 Q.ty	171 Q.ty	
1	00A25R0570	2	2	Testa motore completa Complete cylinder head Culasse complète Zylinderkopf Komplete
2	00547R0760	2	2	Molla leva alzavalvola Spring Ressort Feder
3	00355R0240	2	2	Distanziale Spacer Entretoise Distanzstück
4	00771R0110	2	2	Rondella piana D.8,4x15 sp.1,5 Washer Rondelle Unterlegscheibe
5	00491R0070	2	2	Leva alzavalvola Lever Levier Hebel
6	00994R0260	2	2	Vite M.5x18 Screw Vis Schraube
7	0021350560	1	1	Cappellotto Cap Capuchon Schutzkappe
8	00997R0650	2	2	Vite M.5x12 Screw Vis Schraube
9	00326R0550	2	2	Dado M.5 Nut Ecrou Mutter
10	00926R0840	1	1	Tirante leva alzavalvola Tie rod Entretoise Zugstange
11	00296R0770	1	1	Cuffia per alzavalvola Protection Protection Schutz
12	0035150350	1	1	Distanziale puleggia H.23 Spacer Entretoise Distanzstück
13	00355R0060	1	1	Distanziale pul.Recoil H.31,5 Spacer Entretoise Distanzstück
14	00326R0490	1	1	Dado M.22x1,5 H.13 Nut Ecrou Mutter
15	0025696810	1	1	Convogliatore aria Air conveyor Coiffe ventil Ventilatorhaube
16	00000R9580	1	1	Recoil completo Complete Recoil Recoil complet Ganz Recoil
17	00692R0430	1	1	Puleggia innesto Pulley Poulie Anwerfscheibe
18	00234R0420	1	1	Coperchio Cover Couvercle Deckel
19	00541R0140	1	1	Molla Spring Ressort Feder
20	0049040380	1	1	Fune con manopola Cord with knob Corde avec bouton Seil und Griff
21	00518R0200	1	1	Manopola Knob Bouton Knopf
22	0032030210	6	6	Dado autobloccante M.6 H.7,6 Nut Ecrou Mutter
23	0076250080	6	6	Rondella piana D.12x6,5 Washer Rondelle Unterlegscheibe
24	00555R0490	1	1	Molla a spirale Spring Ressort Feder
25	00692R0440	1	1	Puleggia avv. recoil Pulley Poulie Anwerfscheibe
26	00495R0720	2	2	Leva di innesto Lever Levier Hebel
27	00555R0500	1	1	Molla Spring Ressort Feder
28	0097300180	3	3	Vite M.6x45 Screw Vis Schraube
29	0075650040	1	1	Rondella diam. 6 Washer Rondelle Scheibe
30	0032400080	1	1	Dado M 6 Nut Écrou Mutter

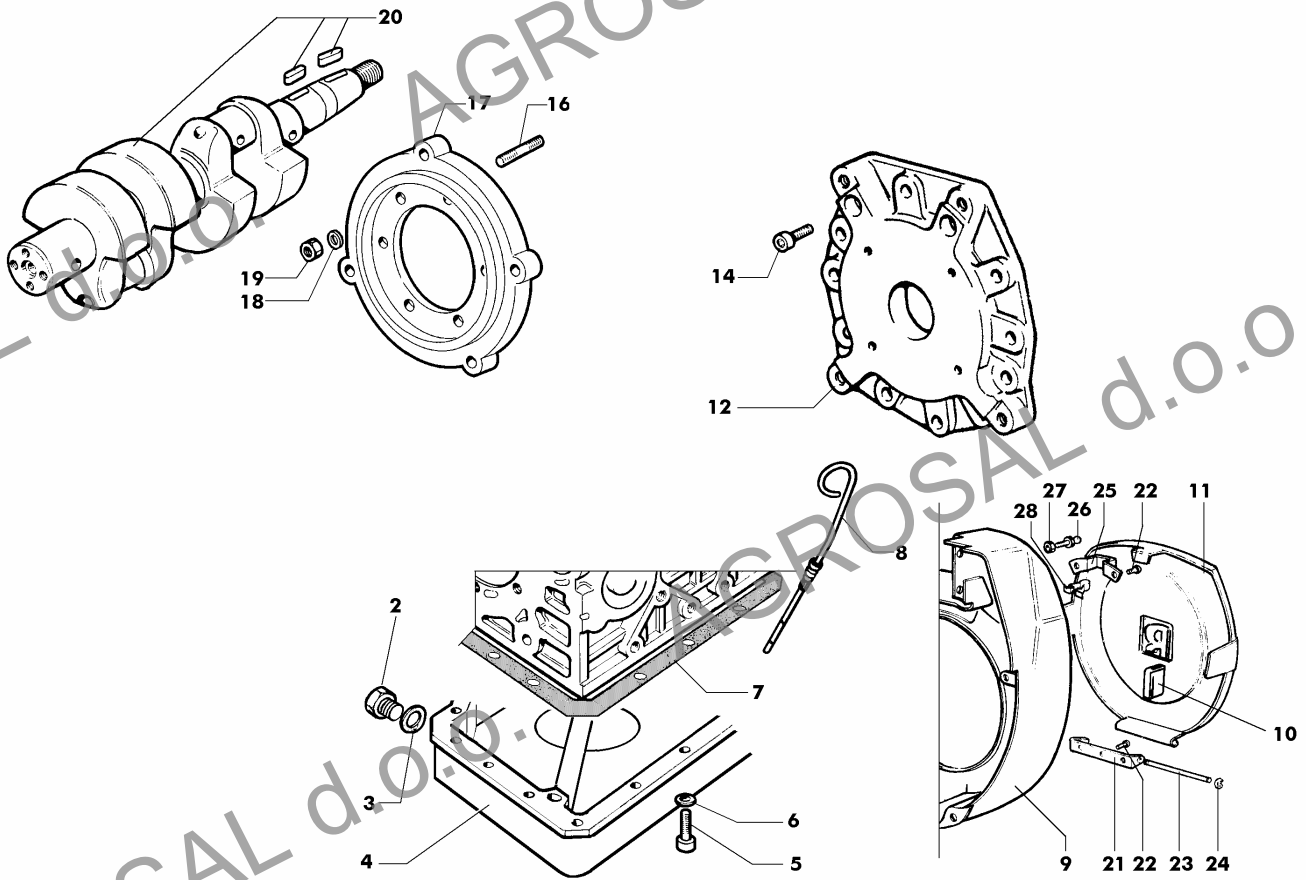

Nr. No.	CODE	MD	MD	DENOMINAZIONE - DESCRIPTION - DENOMINATION - BENENNUNG
		170 Q.ty	171 Q.ty	
2	0089650050	2	2	Tappo M,14x1,5 L.15 Plug Bouchon Verschluß
3	0046700610	2	2	Guarnizione in rame d.14 Gasket Joint Dichtung
4	00248R0860	1	1	Coppa olio lamiera profonda Oil Pan Carter Huile Ölwanne
5	00992R0040	15	15	Vite M.6x18 Screw Vis Schraube
6	0076250080	15	15	Rondella piana D.12x6,5 Washer Rondelle Unterlegscheibe
7	00451R0220	1	1	Guarnizione coppa olio Gasket Joint Dichtung
8	00076R0590	1	1	Asta livello olio coppa profonda Rod Tige Stange
9	0025696770	1	1	Convogliatore STD Shroud Coiffe Ventil Ventilatorhaube
10	00354R0880	2	2	Distanziale Spacer Entretoise Distanzstück
11	00688R0230	1	1	Protezione puleggia Guard Protection Schutz
12	00400R0420	1	1	Flangia accopp.SAE A/B fil.metri. Flange Bride Flansch
14	0097320740	6	6	Vite M 8 x 20 Screw Vis Schraube
16	00676R0700	6	6	Prigioniero M.8x20 Stud Goujon Stiftschraube
17	00399R0870	1	1	Flangia accopp. 7" T Flange Bride Flansch
18	0076250120	6	6	Rondella Washer Rondelle Unterlegscheibe
19	00323R0030	6	6	Dado M.8 H.8 Nut Ecrou Mutter
20	00A23R0190	1	1	Albero a gomiti a flangia Crankshaft Vilebrequin Kurbelwelle
21	00879R0880	1	1	Supporto copripuleggia Support Support Lager
22	00738R0110	5	5	Ribattino D.3x8 Rivet Rivet Niete
23	00601R0530	1	1	Perno supporto copripuleggia Journal Axe Zapfen
24	0011650040	2	2	Anello seeger D.5 Snap ring Circlip Sicherungsring
25	00613R0170	1	1	Piastrina Safety plate Support Sicherungsblech
26	00601R0730	1	1	Perno x attacco rapido Journal Axe Zapfen
27	0032400030	1	1	Dado Nut Ecrou Mutter
28	00555R0320	1	1	Molla copripuleggia Spring Ressort Feder

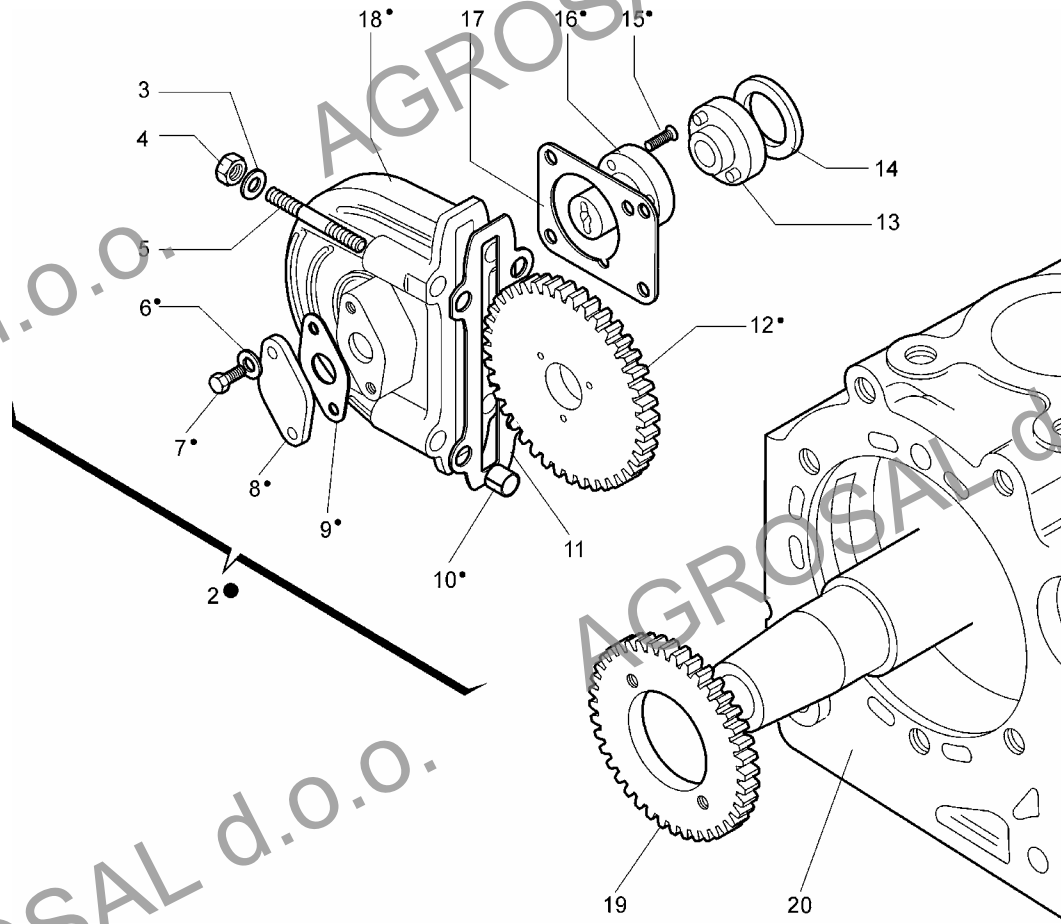

Nr. No.	CODE	MD 170 Q.ty	MD 171 Q.ty	DENOMINAZIONE - DESCRIPTION - DENOMINATION - BENENNUNG			
2	00880R0950	1	1	Kit supporto pompa idraulica	Support	Support	Lager
3	0076250120	4	4	Rondella	Washer	Rondelle	Unterlegscheibe
4	00323R0030	4	4	Dado M.8 H.8	Nut	Ecrou	Mutter
5	00676R0230	4	4	Prigioniero M.8x51	Stud	Goujon	Stiftschraube
6	00771R0010	2	2	Rondella piana 5,3x10	Washer	Rondelle	Unterlegscheibe
7	00993R0780	2	2	Vite M.5x12	Screw	Vis	Schraube
8	00231R0950	1	1	Coperchio	Cover	Couvercle	Deckel
9	00448R0990	1	1	Guarnizione	Gasket	Joint	Dichtung
10	00850R0570	2	2	Spina elastica	Taper pin	Goupille	Kegelstift
11	00450R0870	1	1	Guarnizione	Gasket	Joint	Dichtung
12	00469R0680	1	1	Ingranaggio	Gear	Engrenage	Zahnrad
13	00814R0690	1	1	Semigiunto per GR.1	Half coupling	Demi-accoupl.	Kupplung
14	00042R0020	1	1	Anello riduz. per GR.1	Ring	Bague	Ring
15	00998R0040	3	3	Vite M5x20	Screw	Vis	Schraube
16	00602R0310	1	1	Perno pompa idraulica	Journal	Axe	Zapfen
17	00448R0010	1	1	Guarnizione pompa idraulica GR.1	Gasket	Joint	Dichtung
18	00880R0650	1	1	Supporto pompa idraulica	Support	Support	Lager
19	00469R0690	1	1	Ingranaggio compando pompa	Gear	Engrenage	Zahnrad
20	00A26R0270	1	1	Carter motore per pompa idraulica	Crankcase	Carter moteur	Kurbelgehäuse