

AGROSAL d.o.o.



LOMBARDINI
A KOHLER COMPANY

8LD



AGROSAL d.o.o.

Gregorčičeva ulica 38, 5270 Ajdovščina
telefon: 05 368 90 96, fax: 05 368 90 97
e-mail: info@agrosal.si, www.agrosal.si

**INTAKE AND EXHAUST**

POS.	CODE	DESCRIPTION	Qty
1	3700.179	AIR CLEANER	1
1a	3700.180	air cleaner	1
2	3240.021	nut M 8	3
3	7565.007	washer diam. 8	3
4	4776.062	gasket	1
5	7565.007	washer diam. 8	3
6	3240.021	nut M 8	3
7	4420.012	gasket	2
8	9400.048	suction line	1
9	5496.110	upper filter.element	1
10	8635.096	vibration-damping	1
11	4776.062	gasket	1
12	2486.078	inlet manifold	1
14	3240.164	nut M 8	4
15	3525.080	spacer	1
16	4776.032	gasket h= 7 diam. 154	1
17	5496.075	filtering element	1
18	7565.007	washer diam. 8	4
19	3240.069	nut	4
20	9170.018	muffler end (d.36,5/38)	1
21	3240.018	nut M 8	1
22	7300.091	connection	1
23	4670.014	copper gasket diam.12	1
24	<----->	see Pos. 1	0
25	4115.048	hook	2
26	4420.011	gasket	2
27	5462.056	eXhaust muffler	1
28	7565.007	washer diam. 8	1
29	1770.005	bolt M 8 X 1,25 X 22	1
30	2485.081	ehXhaust manifold	1
31	3825.020	flange for muffler	1
32	2942.021	eXhausting elbow	1
33	3200.002	wing nut M 6	1
34	4775.137	gasket	1
36	7625.092	washer diam. 6,5	1
37	1301.069	cyclonic prefilter (Ø 138)	1
37a	2125.056	prefilter cap	1
39	2942.020	prefilter support	1
40	<----->	gasket	0

A

8LD

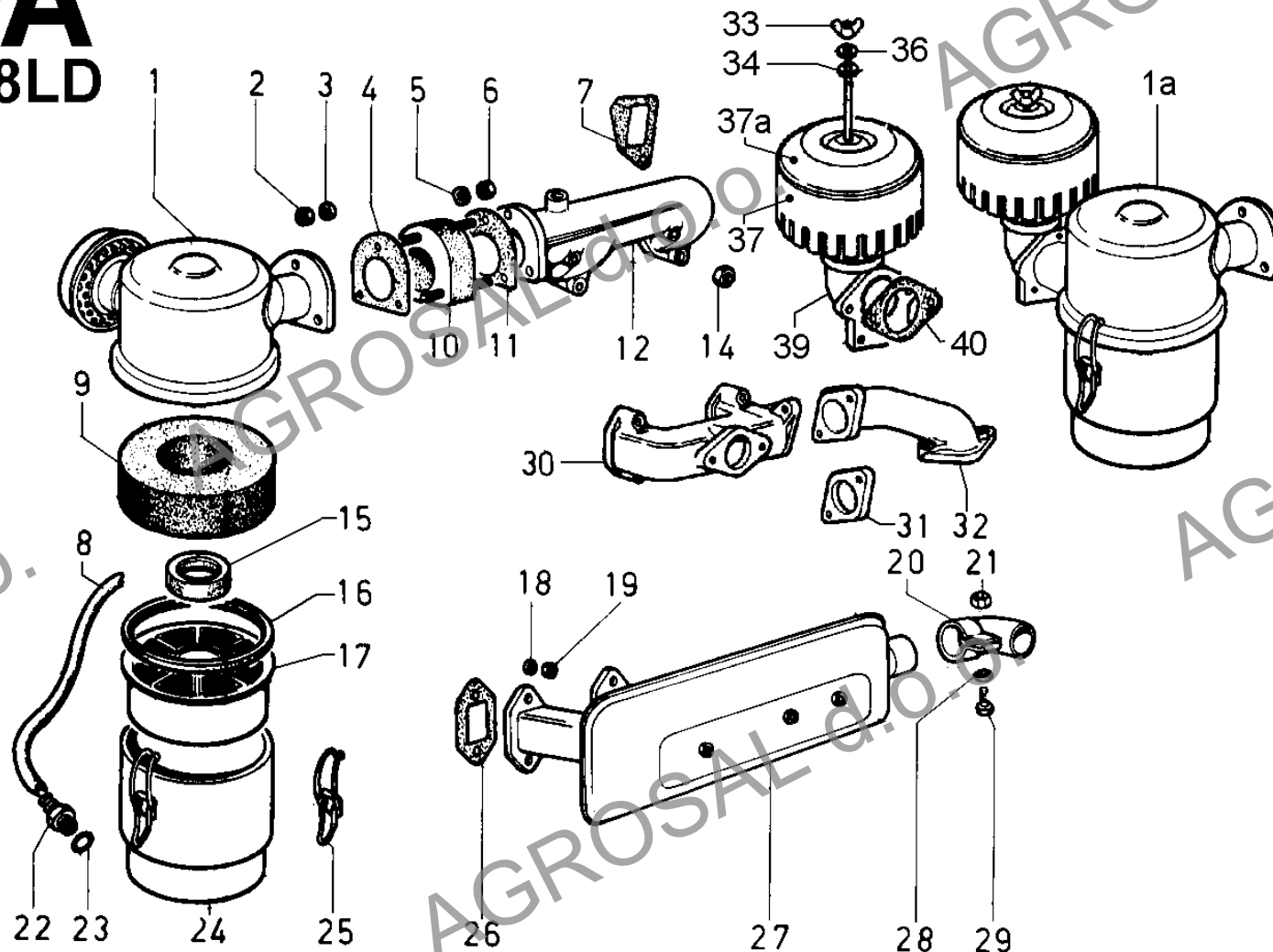

**LOMBARDINI**

A KOHLER COMPANY

Group: 8LD

Engine: 8LD 600-2 Drawing: B

CONNECTING ROD/PISTON SET/CYLINDER

POS.	CODE	DESCRIPTION	Qty
1	1526.020	CONNECTING ROD	2
2	8210.083	ring set std.	2
2	8210.084	ring set +0,50	2
2	8210.085	ring set +1,00	2
3	<----->	PISTON SET +0,50 - no longer avail.	0
3	6502.048	PISTON SET std.	2
4	8480.026	gudgeon pin	2
5	1240.026	snap ring	4
6	1630.012	small end bearing	2
7	1780.135	bolt M 10 X 1,5 X 50	4
8	<----->	plate	0
11	1640.040	big end bushing std.	2
11	1640.052	big end bushing -0,25	2
11	1640.053	big end bushing -0,50	2

B

8LD

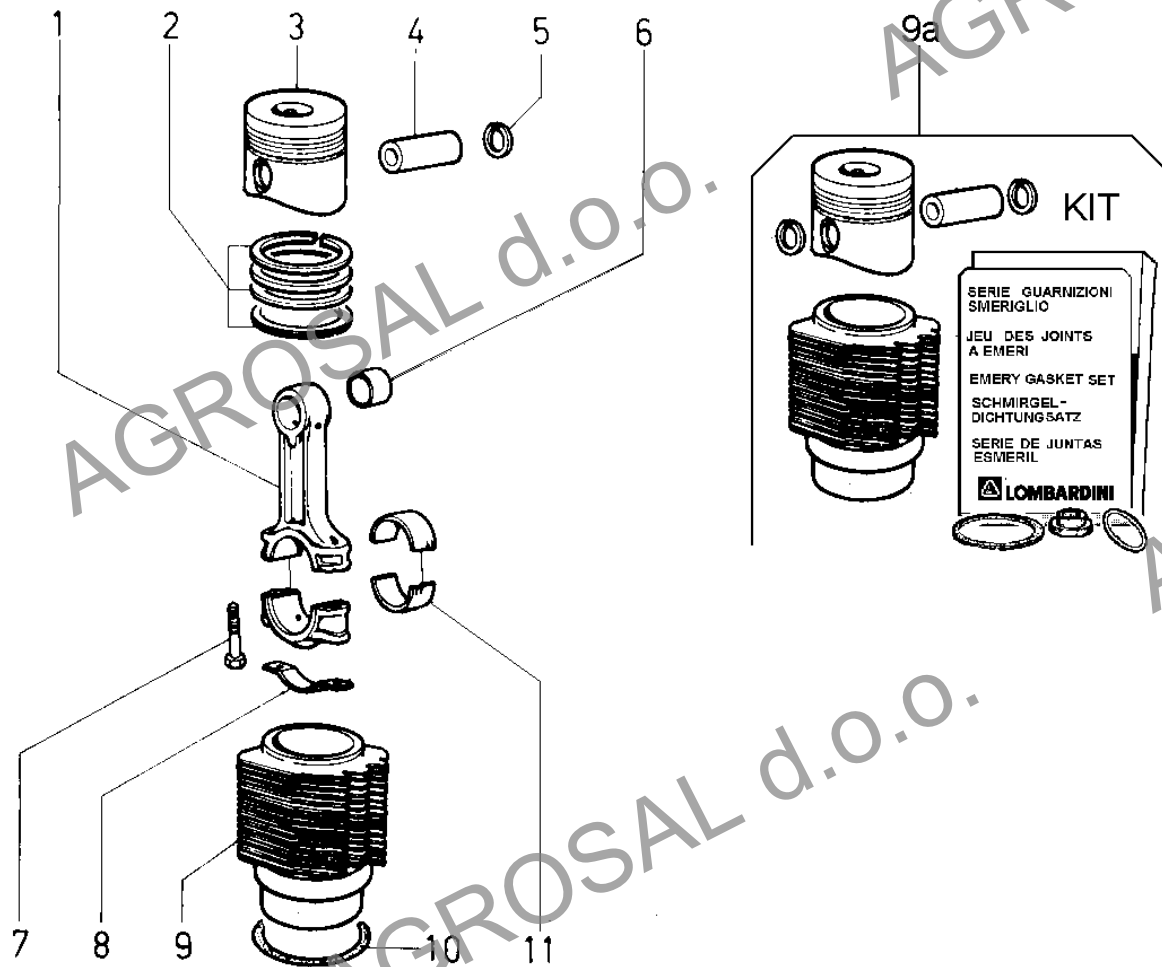

**LOMBARDINI**

Group: 8LD

A KOHLER COMPANY

Engine: 8LD 600-2 Drawing: I

CONTROLS

POS.	CODE	DESCRIPTION	Qty
1	7626.051	washer	1
2	<----->	lever - see Pos. I 33	0
4	1760.041	bolt M 6 X 1 X 40	1
5	3240.058	nut	1
6	<----->	see Pos. 39	0
7	1200.034	O ring 105	2
8	<----->	spring	0
9	1240.001	snap ring	1
10	<----->	lever - no longer avail.	0
11	9732.092	screw M 8 X 18	1
12	<----->	gasket	0
13	3240.008	nut M 6	1
14	5168.039	tabwasher	1
15	7625.007	washer diam. 6	1
16	1760.032	bolt M 6 X 1 X 14	1
17	8576.006	eXtra fuel device	1
18	6870.021	stud	1
19	<----->	pin	0
20	8430.023	lockpin 3 X 16	1
22	<----->	pin	0
24	7625.012	washer diam. 8,4	1
25	<----->	bolt M 6 X 1 X 55 - no longer avail.	0
26	3240.008	nut M 6	1
27	7565.004	washer diam. 6	2
28	1760.010	bolt M 6 X 1 X 30	2
29	5271.002	lever	1
30	5271.027	lever	1
31	<----->	pin	0
32	1760.006	bolt M 6 X 1 X 20	2
33	7865.072	GOVERN.HOUSING	1
34	<----->	cotter pin - no longer avail.	0
35	5655.048	spring	1
36	<----->	sleeve	0
37	7565.004	washer diam. 6	2
38	4776.031	gasket	1
39	2691.092	CONTROL COVER	1
40	9732.016	screw M 6 X 40	6
41	<----->	see Pos. 39	0
42	7625.098	washer diam. 8,4	1
43	6545.009	knob	1
44	<----->	see Pos. 39	0

1
8LD

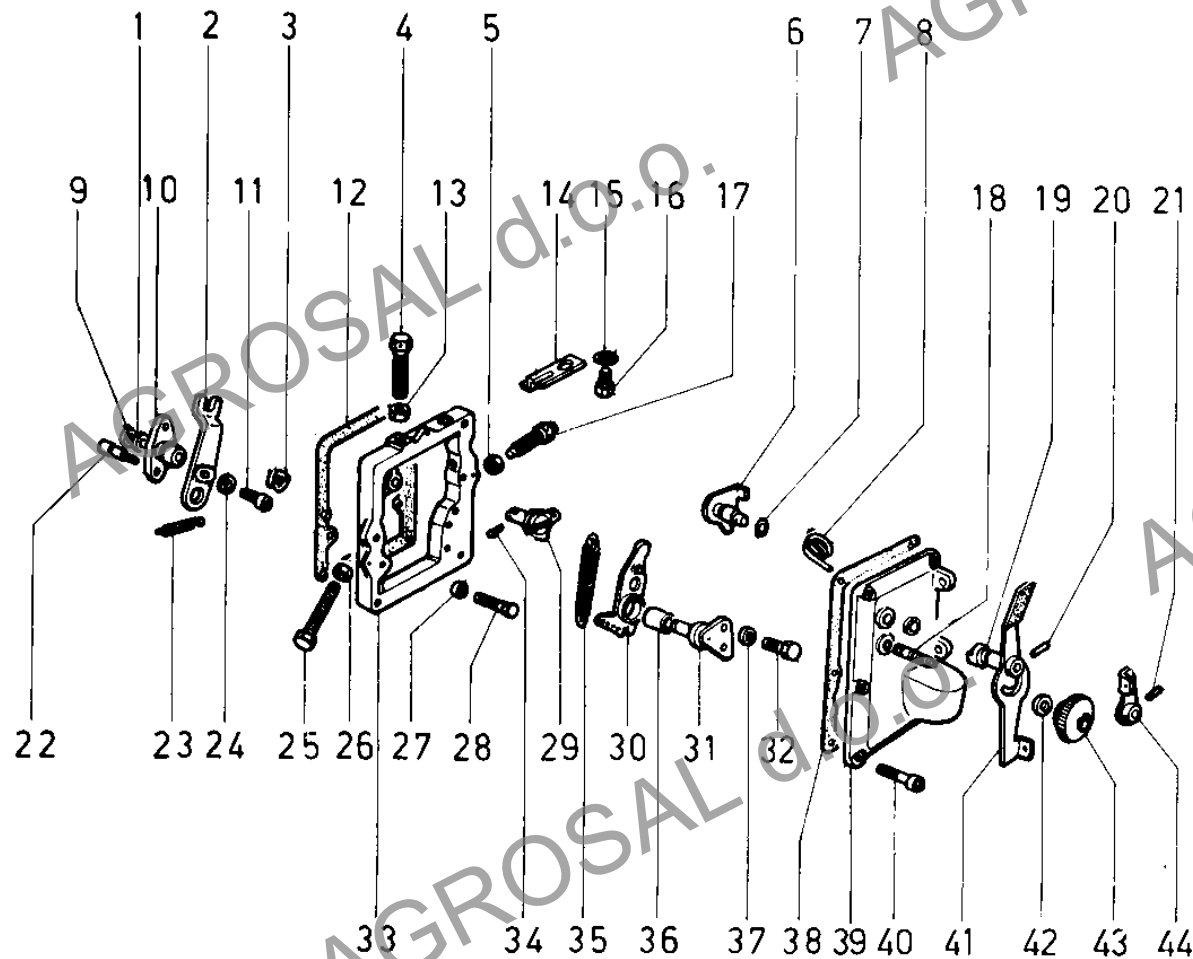

**LOMBARDINI**

A KOHLER COMPANY

Group: 8LD

Engine: 8LD 600-2 Drawing: G

COOLING SYSTEM

POS.	CODE	DESCRIPTION	Qty
1	4776.086	gasket	1
2	1770.002	bolt M 8 X 1,25 X 16	1
3	7565.007	washer diam. 8	1
4	7565.004	washer diam. 6	2
5	1760.003	bolt M 6 X 1 X 12	2
6	«-----»	shroud	0
7	5066.010	airtight plate	1
8	3240.003	nut M 4	2
9	7625.052	washer	1
10	2183.050	hinge link	1
11	9245.066	screw stay	1
12	«-----»	airtight plate	0
13	9790.039	screw M 6 X 12	4
15	7625.070	washer diam. 6	2
16	3350.046	deflector	1
17	2086.051	bell for blower without alternator or with 14A alternator	1
18	7625.112	washer	1
19	3203.015	nut	1
20	7625.012	washer diam. 8,4	3
21	8075.057	half-pulley	1
22	6320.026	spacer 1,00	1
23	3240.008	nut M 6	3
24	7565.004	washer diam. 6	3
25	6760.004	stud M 6 X 14 (23)	3
26	6320.027	spacer 2,00	1
27	3527.018	spacer	1
28	8075.058	half-pulley	1
29	8565.024	alternator stator	1
29	9718.193	BLASTER 12V 14A alternator	1
30	3002.003	ball bearing	1
31	2200.004	key	3
32	3450.044	spacer	1
33	1770.009	bolt M 8 X 1,25 X 35	3
34	3203.015	nut	1
35	6320.025	spacer 0,50	1
36	1760.017	bolt M 6 X 1 X 80	4
37	7565.004	washer diam. 6	4
38	3240.018	nut M 8	3
39	1105.010	blower shaft	1
40	3002.003	ball bearing	1
41	9718.024	blaster fan	1
42	1760.006	bolt M 6 X 1 X 20	2
43	7625.070	washer diam. 6	2
44	6927.023	guard	1
45	7625.112	washer	1
46	2440.034	belt (R.P.M.2000 >) mm 803	1
47	6975.095	pulley	1
48	6780.008	stud M 8 X 20 (32)	3
49	7565.007	washer diam. 8	3
50	9790.039	screw M 6 X 12	4
51	5151.017	panel	1

G

8LD

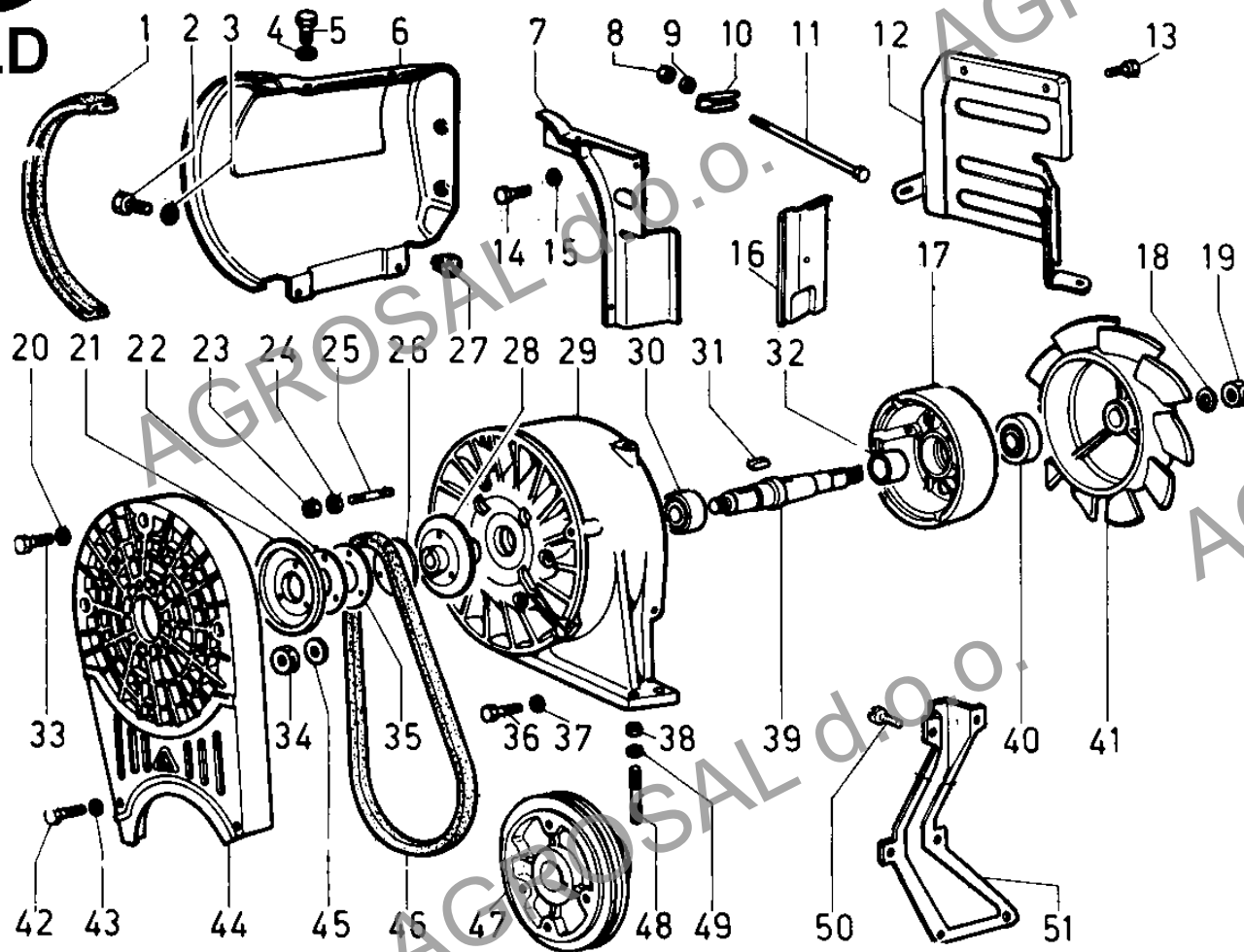

**CRANKCASE/GEAR COVER/MOUNTS**

POS.	CODE	DESCRIPTION	Qty
1	9732.074	screw M 8 X 20	1
2	6647.042	gear cover	1
3	1213.009	seal ring	1
4	4501.023	gasket	1
5	6780.049	intake stud M 8 X 20 (36)	5
6	8460.055	locating dowel	2
7	6850.090	cyl.head stud	8
8	1514.003	CRANKCASE	1
9	9765.009	screw M 8 X 10	1
10	9730.010	screw M 6 X 16	3
11	2615.031	cover	1
12	4776.034	gasket	1
13	3240.164	nut M 8	6
14	1970.073	sleeve	1
15	7565.011	washer diam.10	12
16	6780.064	stud M 8 X 30 (40)	1
17	1770.001	bolt M 8 X 1,25 X 12	1
18	4670.058	copper gasket diam. 8,2X12X1,5	1
19	1200.117	rubber oil seal	1
20	6428.075	engine mount	4
21	9730.100	screw M 8 X 25	9
22	9731.077	screw M 8 X 85	2
23	9732.075	screw M 8 X 50	1
24	<----->	cover - no longer avail.	0
25	4431.047	gasket	1
26	6780.068	stud M 8 X 18 (30)	1
27	<----->	cover	0
28	7565.007	washer diam. 8	3
29	3240.018	nut M 8	3
30	1780.006	bolt M 10 X 1,5 X 30	12

E
8LD

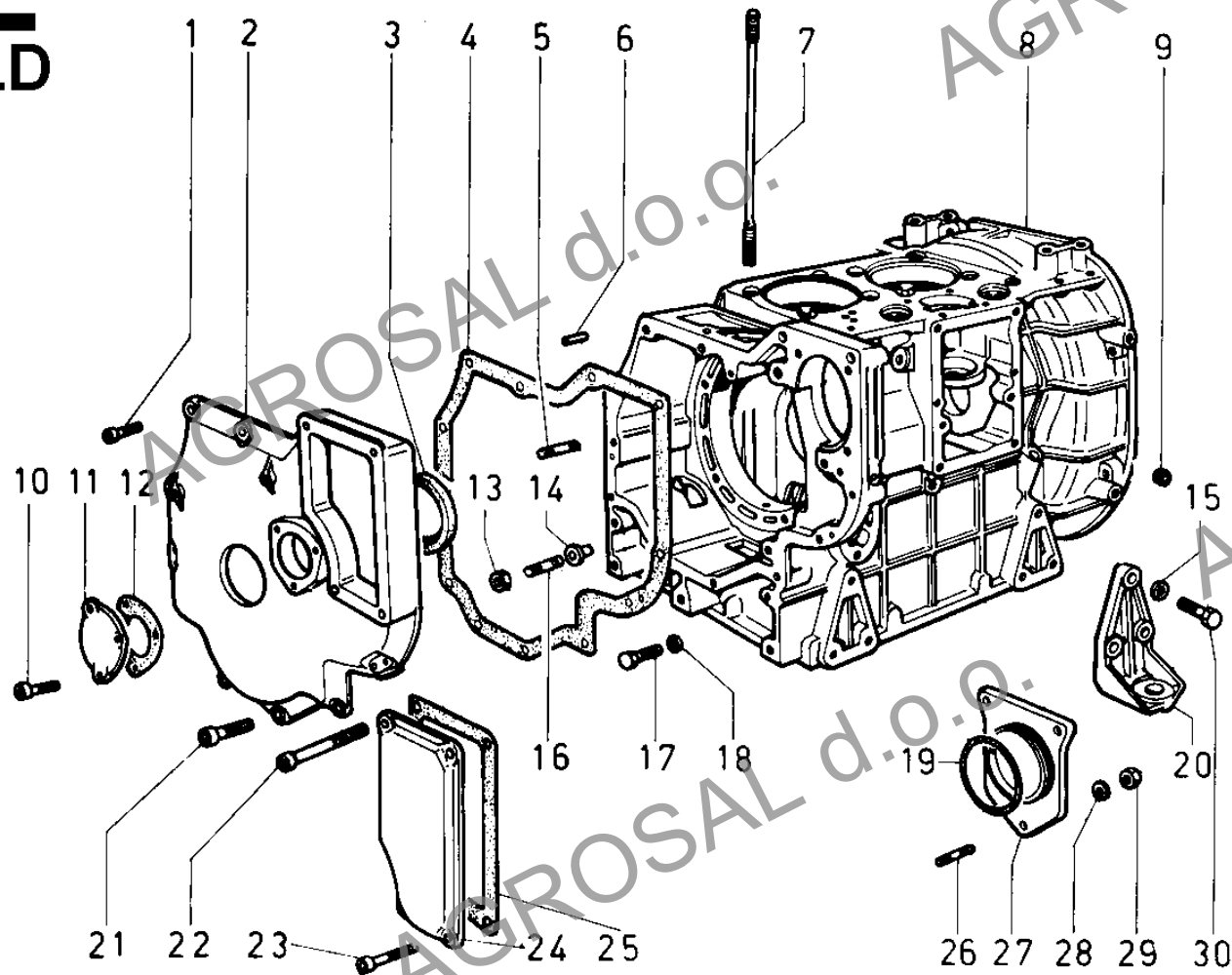

**LOMBARDINI**

A KOHLER COMPANY

Group: 8LD

Engine: 8LD 600-2 Drawing: C

CRANKSHAFT AND SUPPORTS/FLYWHEEL

POS.	CODE	DESCRIPTION	Qty
1	7530.020	washer	1
2	8675.204	support	1
3	1202.015	rubber oil seal	1
4	1611.131	bearing std. (gear side)	1
4	1611.132	bearing -0,25 (gear side)	1
4	1611.133	bearing -0,50 (gear side)	1
5	9000.073	eXpansion plug	4
6	1052.015	CRANKSHAFT	1
7	«-----»	bearing -0,50 (flywheel side) & +1,00 on eXtern.diameter	0
7	1611.147	bearing std. (flywheel side)	1
7	1611.148	bearing -0,50 (flywheel side)	1
7	1611.149	bearing -0,25 (flywheel side)	1
7	1611.150	bearing std.(flywheel side) & +1,00 on eXtern.diameter	1
7	1611.152	bearing -0,25 (flywheel side) & +1,00 on eXtern.diameter	1
8	1213.005	seal ring	1
9	9885.072	FLYWHELL with CROWN	1
10	5111.005	tabwasher	1
11	1861.045	bolt Es.50 l=52 d= -	1
12	3260.057	nut	1
13	3000.004	ball bearing	2
14	2280.042	key	2
15	1610.082	main bearing shell c. std.	1
15	1610.098	main bearing shell c. -0,25	1
15	1610.099	main bearing shell c. -0,50	1
16	5957.003	lockpin	1
17	1780.015	bolt M 10 X 1,5 X 70	1
18	5111.069	safety plate	1
19	8676.008	MIDDLE SUPPORT	1
20	9730.034	screw M 8 X 55	2
21	2280.056	crankshaft wooddruff key	1
22	2816.025	crown gear	1

C
8LD

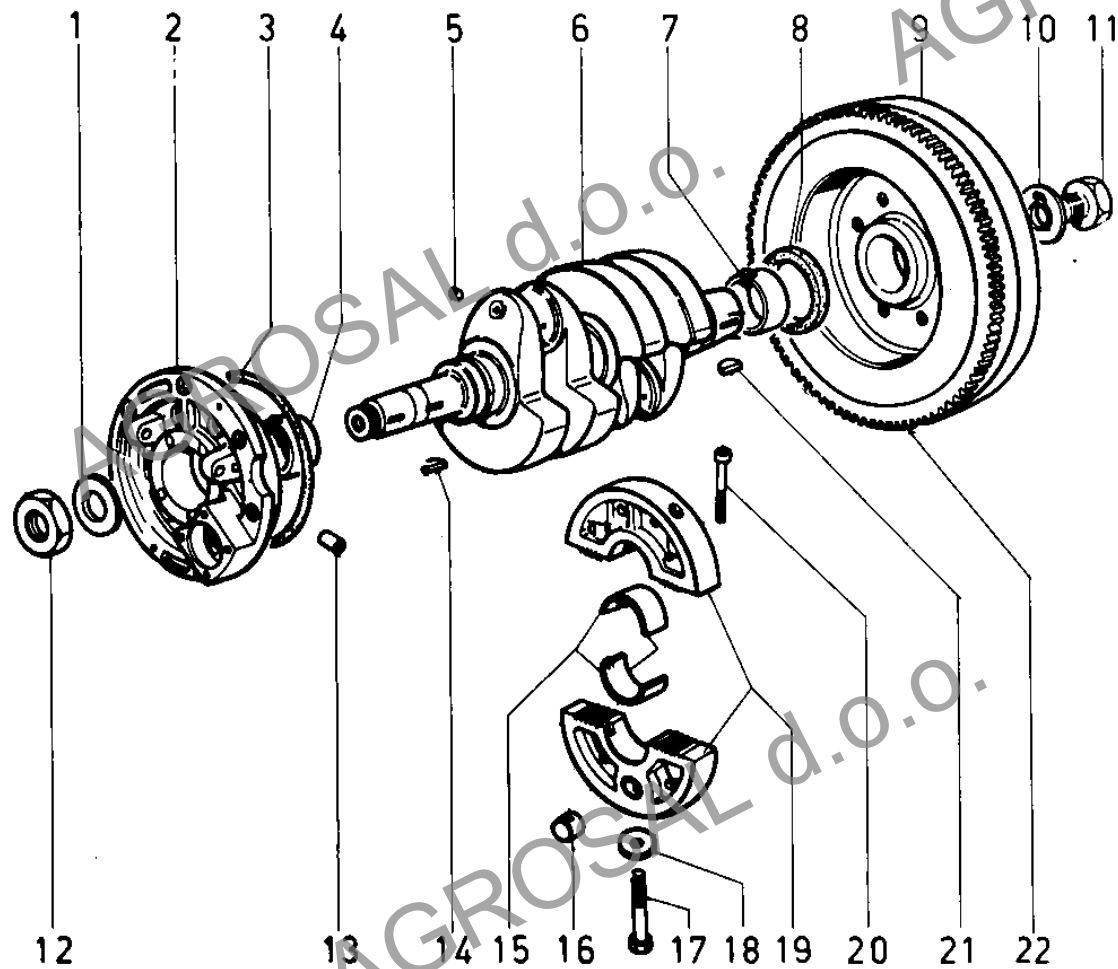

**LOMBARDINI**

A KOHLER COMPANY

Group: 8LD

Engine: 8LD 600-2 Drawing: L

CYLINDER HEAD/ROCKER ARM BOX/VALVES

POS.	CODE	DESCRIPTION	Qty
1	<----->	washer diam.10,5	0
2	3240.124	nut	8
3	8506.003	engine lifting eye	2
4	9731.040	screw M 8 X 60	4
5	9032.064	FILLER OIL CAP	1
6	1200.015	O ring 137 for filler oil cap	1
7	2125.079	rocker arm cover with hole for oil filling	1
8	6410.018	retainer with half-collets	4
9	4330.041	ROCKER ARM ASS.Y	1
10	3240.010	nut M 7	4
11	<----->	safety plate	0
12	3240.018	nut M 8	4
13	8655.004	ROCKER ARM SHAFT	2
14	3240.010	nut M 7	2
15	7701.022	washer	8
16	1240.007	snap ring	4
17	<----->	eXhaust v.guide +0,50	0
17	4845.248	eXhaust v.guide std.	2
18	1160.021	circlip	4
19	4845.182	inlet v.guide std.	2
19	4845.183	inlet v.guide +0,50	2
20	4400.021	gasket 0,50	2
21	<----->	ROCKER ARM COVER	0
22	9201.072	CYLINDER HEAD WITH SEATS AND GUIDES	2
23	1202.013	O ring 108	2
24	<----->	pin - no longer avail.	0
25	5755.004	valve spring	4
26	2135.072	cap	2
27	9850.055	screw	2
28	6780.091	stud M 8 X 38 (51)	4
29	9765.001	screw M 6 X 8	2
30	9850.002	rocker arm adjuster	4
31	<----->	see Pos. 9	0
32	9820.080	screw	2
33	4670.062	copper gasket diam. 6,2 X 10 X 1,5	2
34	8000.057	eXhaust v.seat	2
35	<----->	head gasket 0,65	0
35	4730.022	head gasket 0,80	2
35	4730.058	head gasket 1,00	2
35	4730.059	head gasket 0,60	2
35	4730.072	head gasket 0,70	2
35	4730.073	head gasket 0,90	2
35	4730.331	head gasket 1,05	2
35	4730.332	head gasket 1,10	2
36	8000.031	inlet v.seat	2
37	6780.085	stud M 8 X 35 (47)	4
38	6780.012	stud M 8 X 25 (37)	2
39	6780.059	stud M 8 X 80 (92)	2
40	3430.067	spring seat (bottom)	4
41	9685.040	eXhaust valve	2
42	9652.030	intake valve	2

L
8LD

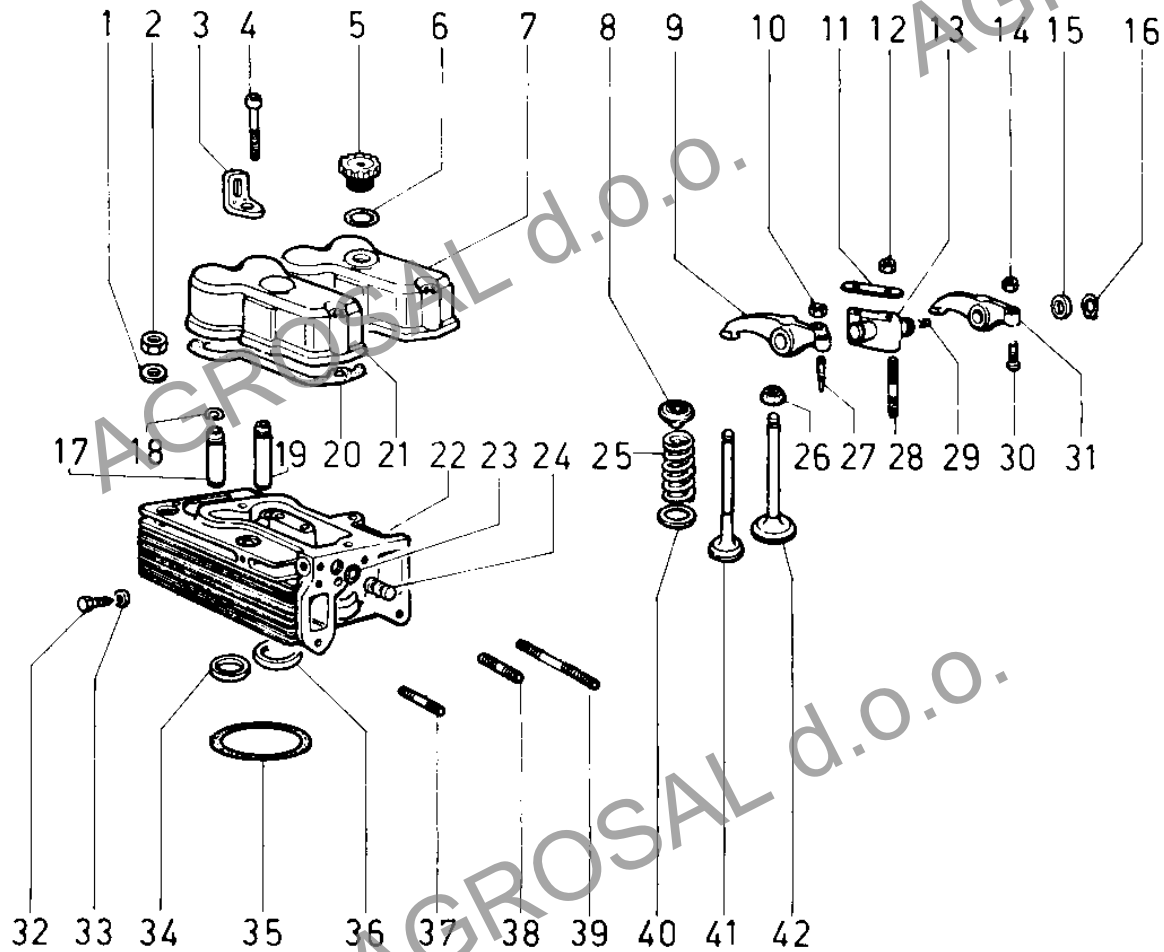

**FUEL SYSTEM**

POS.	CODE	DESCRIPTION	Qty
1	9371.101	bleeding pipe mm 745	1
2	3240.008	nut M 6	4
3	7565.004	washer diam. 6	4
4	3790.074	injector top plate	2
5	4670.058	copper gasket diam. 8,2X12X1,5	1
6	1901.029	union bolt M 8	1
7	4670.058	copper gasket diam. 8,2X12X1,5	1
9	1901.029	union bolt M 8	1
10	7301.006	connection	2
11	<----->	gasket	0
12	9600.057	rubber spacer	4
13	9730.139	screw M 6 X 60	2
14	1557.019	drilled block	2
15	1557.020	threaded block	2
16	9043.092	fuel tank cap	1
17	8102.085	FUEL TANK 10 lt (410X190X140)	1
18	6760.045	stud M 6 X 65 (80)	4
19	4670.058	copper gasket diam. 8,2X12X1,5	1
20	1755.002	bolt M 5 X 0,8 X 12	2
21	9374.099	high press pipe	1
22	3616.085	fuel tank strap mm 625	2
23	9375.276	fuel hose mm 430	1
24	4670.059	copper gasket diam.10	1
26	1901.030	union bolt M 10	1
27	6615.018	NOZZLE-HOLDER	2
28	6531.265	nozzle	2
29	3616.018	injector feed pipe saddle	2
30	5400.046	rubber sheathing	2
31	5575.006	spring	1
32	6585.051	feed pump	1
33	3240.164	nut M 8	1
34	3300.155	nut	1
35	4670.005	copper gasket 0,50	2
35	4670.006	copper gasket 1,00	2
36	9375.001	high press.pipe	1
37	8866.018	support	1
38	4701.006	gasket	1
39	3930.019	cup	1
40	9375.005	hose mm 235	1
41	4670.059	copper gasket diam.10	1
42	7565.007	washer diam. 8	1
43	8335.029	washer seal	2
44	7470.003	filler	2
45	1200.031	rubber oil seal	2
46	7265.008	connection	2
47	5755.034	valve spring	2
48	9572.012	delivery valve BOSCH	2
49	1200.268	rubber oil seal	1
50	4670.059	copper gasket diam.10	1
51	8836.016	support	1
52	4580.169	gasket 0,40	1
52	4580.170	gasket 0,80	1
53	6578.013	injection plunger	2

Group: 8LD
Engine: 8LD 600-2 Drawing: F

FUEL SYSTEM

POS.	CODE	DESCRIPTION	Qty
54	4760.015	valve gasket	2
55	9730.100	screw M 8 X 25	4
56	4670.050	copper gasket diam.12	1
57	1901.012	union bolt	1
58	1570.056	union bolt	1
59	9732.074	screw M 8 X 20	4
60	7565.007	washer diam. 8	4
61	2175.009	fuel filter cartridge	1
61	3730.015	FUEL FILTER	1
62	3630.008	clamp	1
63	4430.071	gasket	1
64	4490.017	gasket	1
65	1901.030	union bolt M 10	1
66	7200.060	drive rod	1
67	6780.028	stud M 8 X 55 (67)	2
68	4580.169	gasket 0,40	1
68	4580.170	gasket 0,80	1
69	9080.035	cap	1
70	4670.060	copper gasket diam.12	1
71	7625.010	washer diam. 8	4
72	4670.060	copper gasket diam.12	1
73	4670.058	copper gasket diam. 8,2X12X1,5	2
74	<----->	injector rack	0
75	2605.033	filter cover	1
76	1202.052	rubber oil seal	1
77	1760.162	bolt	1
78	<----->	plate	0
79	6590.034	injection pump	1
80	8400.048	taper pin	1
81	2800.003	cotter pin	1
82	4850.009	guide	1
83	4580.002	gasket 0,10	4
83	4580.009	gasket 0,50	1
83	4580.068	gasket 0,05	1
84	7980.020	cup	2
85	<----->	union bolt	0
88	6230.069	pin	1
89	1580.023	bushing	1
90	771R.001	washer diam. 5,3	1
91	6230.068	pin	2
92	<----->	see Pos. 39	0
93	7215.017	tappet	2
94	<----->	spring retainer bottom - see Pos. F 79	0
95	5625.002	spring	2
96	<----->	roller (no longer avail.)	0
111	7270.020	banjo union	1

F 8LD

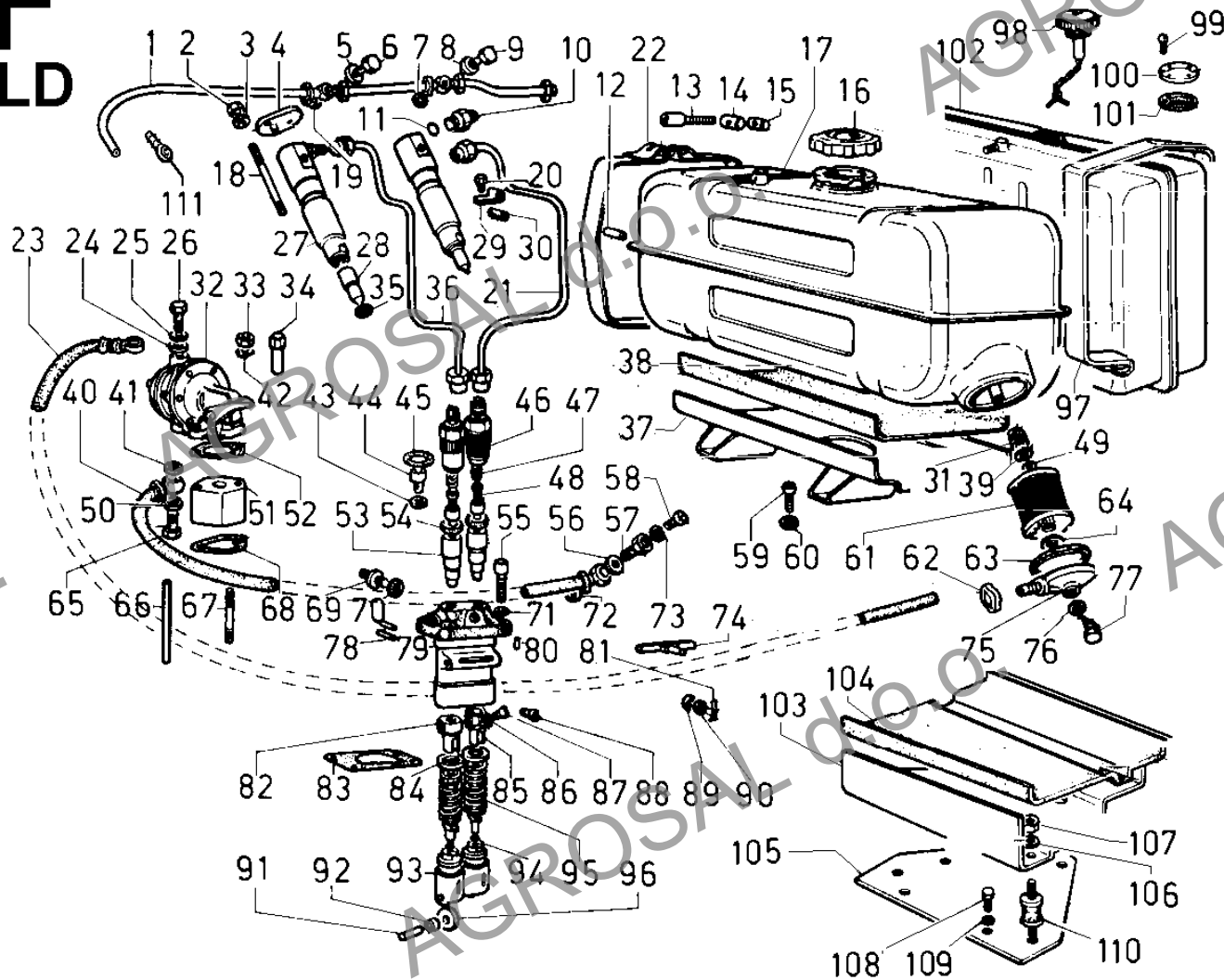

**LOMBARDINI**

A KOHLER COMPANY

Group: 8LD

Engine: 8LD 600-2 Drawing: H

LUBRICATING SYSTEM

POS.	CODE	DESCRIPTION	Qty
1	4670.058	copper gasket diam. 8,2X12X1,5	1
3	1901.050	union bolt M 8	1
4	4670.058	copper gasket diam. 8,2X12X1,5	1
6	1901.050	union bolt M 8	1
7	4670.016	copper gasket diam.14	1
8	«-----»	sleeve	0
9	4670.016	copper gasket diam.14	1
10	4670.058	copper gasket diam. 8,2X12X1,5	1
12	1901.050	union bolt M 8	1
13	9455.037	lubricating pipe	1
14	1400.369	dipstick	1
15	3240.043	nut	1
16	5715.025	spring	1
17	9455.042	lubricating pipe	1
18	1257.022	spacer	1
19	4670.058	copper gasket diam. 8,2X12X1,5	1
20	1257.023	spacer	1
21	4670.058	copper gasket diam. 8,2X12X1,5	1
22	1901.050	union bolt M 8	1
23	4670.016	copper gasket diam.14	1
24	1901.032	union bolt M 14	1
26	4670.016	copper gasket diam.14	1
27	«-----»	gasket	0
28	4217.011	coupling	1
29	7750.032	rotor	1
30	7750.056	rotor	1
31	1760.006	bolt M 6 X 1 X 20	2
32	«-----»	oil filter automotive type	0
32	3740.048	oil filter std	1
33	«-----»	gasket - no longer avail.	0
34	6647.071	OIL PAN std.	1
34	6647.095	OIL PAN AUTOMOTIVE TYPE	1
35	4670.016	copper gasket diam.14	2
36	8965.005	oil drain plug M 14	2
37	1240.018	snap ring	1
38	7490.015	washer	1
39	4936.056	gear	1
40	7565.007	washer diam. 8	1
41	1770.007	bolt M 8 X 1,25 X 30	1
43	7565.007	washer diam. 8	4
44	6605.054	LUBR.OIL PUMP	1
44	8780.021	oil pump support	1
45	2175.040	oil filter cartridge	1
46	4730.533	gasket	1
47	3740.160	OIL FILTER	1
48	4670.058	copper gasket diam. 8,2X12X1,5	1
49	7565.007	washer diam. 8	1
50	1770.065	bolt M 8 X 1,25 X 65	1
51	8965.034	plug M 8	1
52	«-----»	guard panel	0
53	9790.039	screw M 6 X 12	9
54	1770.039	bolt M 8 X 1,25 X 28	12
55	7555.029	washer diam. 8	12

Group: 8LD
Engine: 8LD 600-2 Drawing: H

LUBRICATING SYSTEM

POS.	CODE	DESCRIPTION	Qty
56	←----->	guard panel automotive type	0

H

8LD

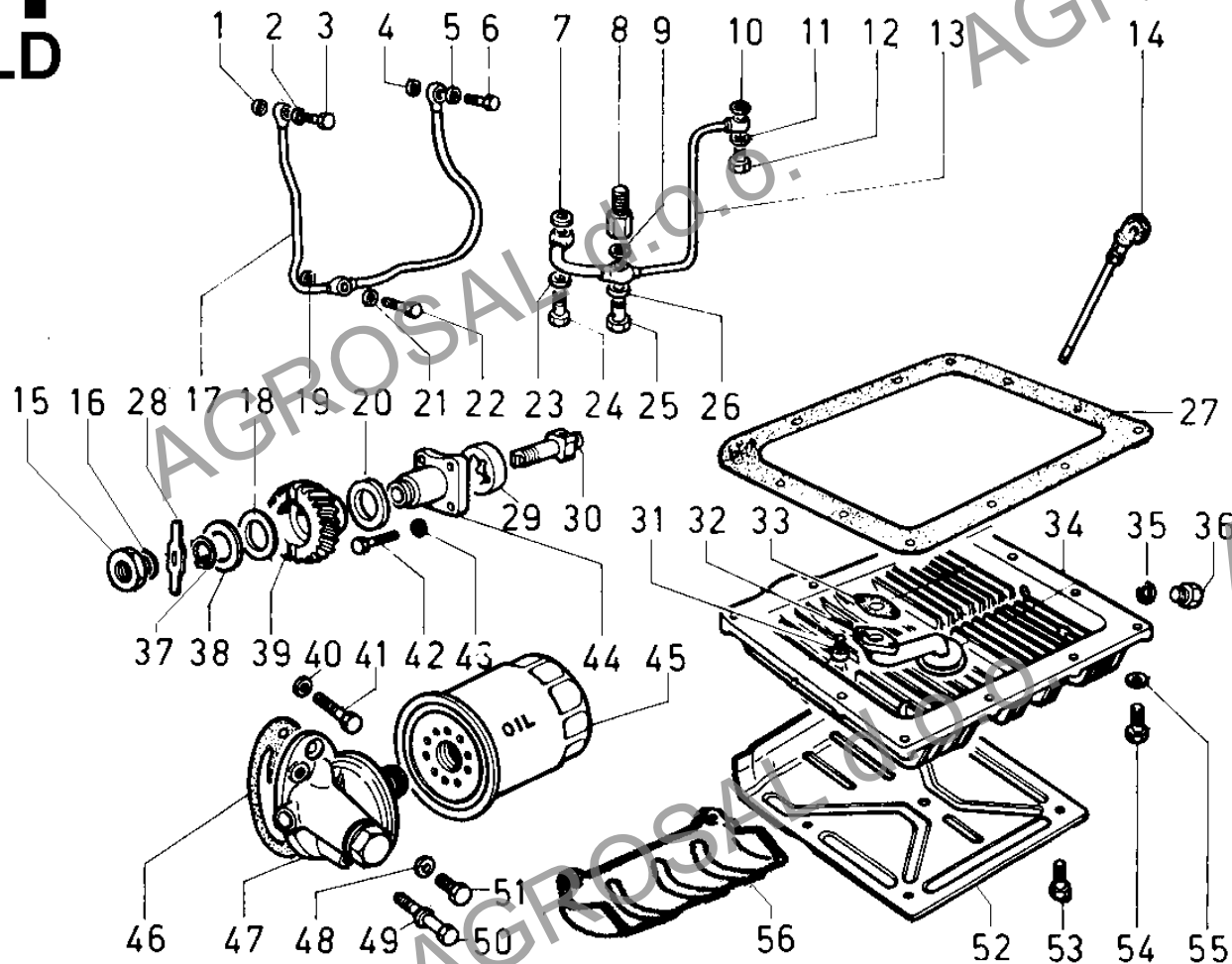

**LOMBARDINI**

A KOHLER COMPANY

Group: 8LD

Engine: 8LD 600-2 Drawing: H

LUBRICATING SYSTEM

POS.	CODE	DESCRIPTION	Qty
1	4670.058	copper gasket diam. 8,2X12X1,5	1
3	1901.050	union bolt M 8	1
4	4670.058	copper gasket diam. 8,2X12X1,5	1
6	1901.050	union bolt M 8	1
7	4670.016	copper gasket diam.14	1
8	<----->	sleeve	0
9	4670.016	copper gasket diam.14	1
10	4670.058	copper gasket diam. 8,2X12X1,5	1
12	1901.050	union bolt M 8	1
13	9455.037	lubricating pipe	1
14	1400.369	dipstick	1
15	3240.043	nut	1
16	5715.025	spring	1
17	9455.042	lubricating pipe	1
18	1257.022	spacer	1
19	4670.058	copper gasket diam. 8,2X12X1,5	1
20	1257.023	spacer	1
21	4670.058	copper gasket diam. 8,2X12X1,5	1
22	1901.050	union bolt M 8	1
23	4670.016	copper gasket diam.14	1
24	1901.032	union bolt M 14	1
26	4670.016	copper gasket diam.14	1
27	<----->	gasket	0
28	4217.011	coupling	1
29	7750.032	rotor	1
30	7750.056	rotor	1
31	1760.006	bolt M 6 X 1 X 20	2
32	<----->	oil filter automotive type	0
32	3740.048	oil filter std	1
33	<----->	gasket - no longer avail.	0
34	6647.071	OIL PAN std.	1
34	6647.095	OIL PAN AUTOMOTIVE TYPE	1
35	4670.016	copper gasket diam.14	2
36	8965.005	oil drain plug M 14	2
37	1240.018	snap ring	1
38	7490.015	washer	1
39	4936.056	gear	1
40	7565.007	washer diam. 8	1
41	1770.007	bolt M 8 X 1,25 X 30	1
43	7565.007	washer diam. 8	4
44	6605.054	LUBR.OIL PUMP	1
44	8780.021	oil pump support	1
45	2175.040	oil filter cartridge	1
46	4730.533	gasket	1
47	3740.160	OIL FILTER	1
48	4670.058	copper gasket diam. 8,2X12X1,5	1
49	7565.007	washer diam. 8	1
50	1770.065	bolt M 8 X 1,25 X 65	1
51	8965.034	plug M 8	1
52	<----->	guard panel	0
53	9790.039	screw M 6 X 12	9
54	1770.039	bolt M 8 X 1,25 X 28	12
55	7555.029	washer diam. 8	12

Group: 8LD
Engine: 8LD 600-2 Drawing: H

LUBRICATING SYSTEM

POS.	CODE	DESCRIPTION	Qty
56	←-----→	guard panel automotive type	0

H

8LD

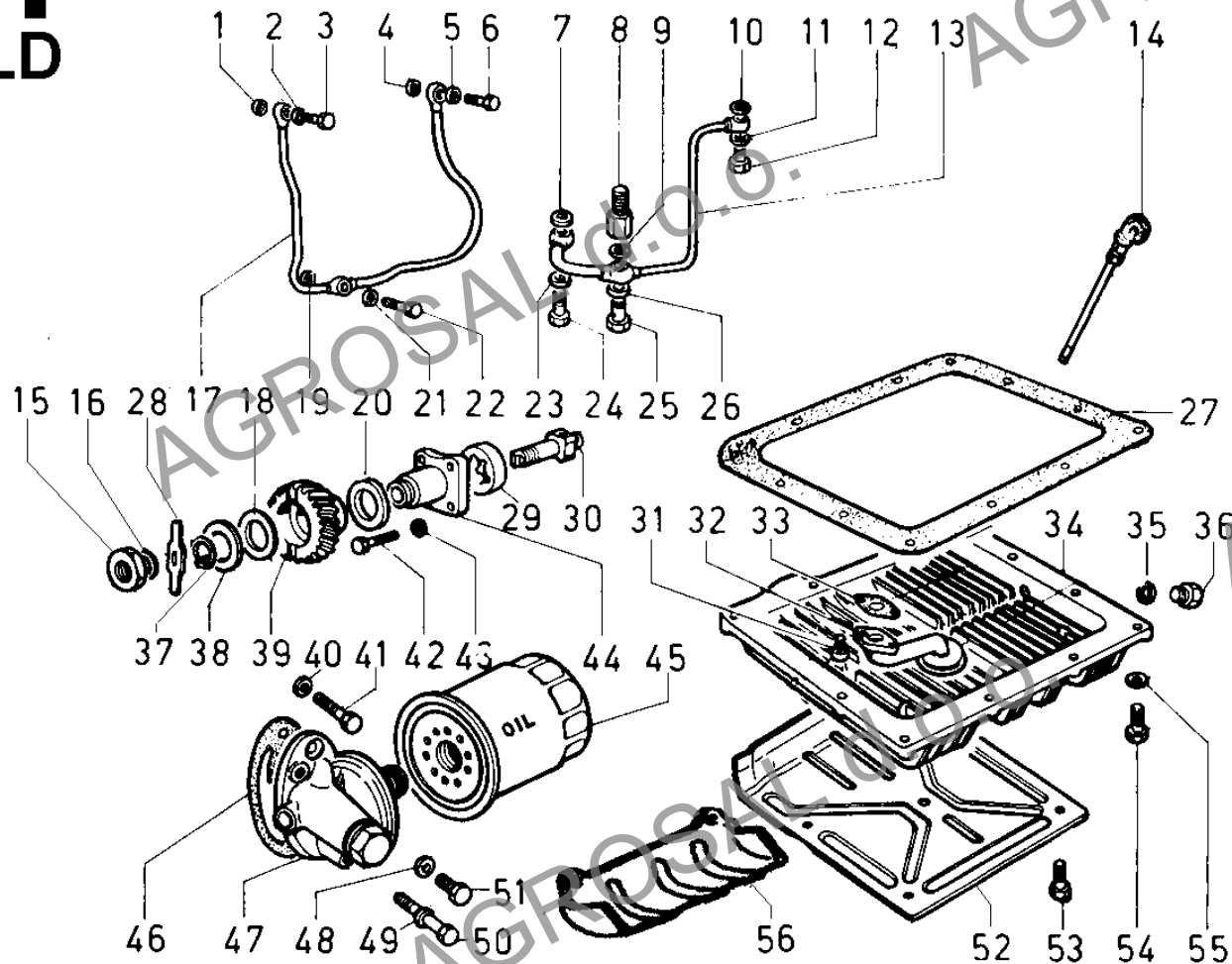

GASKET/RING SET

POS.	CODE	DESCRIPTION	Qty
1	<----->	GASKET SET - see Pos. N 1a	0
1a	8205.097	RING AND GASKET COMPLETE SET	1
1b	8185.018	EMERY GASKET SET	1
2	8150.010	O RING SET	1

N
8LD

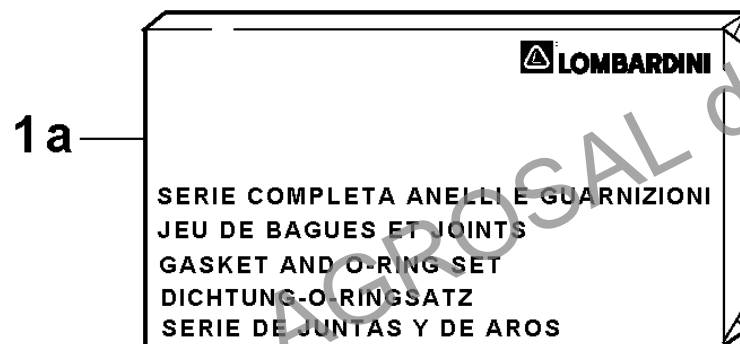
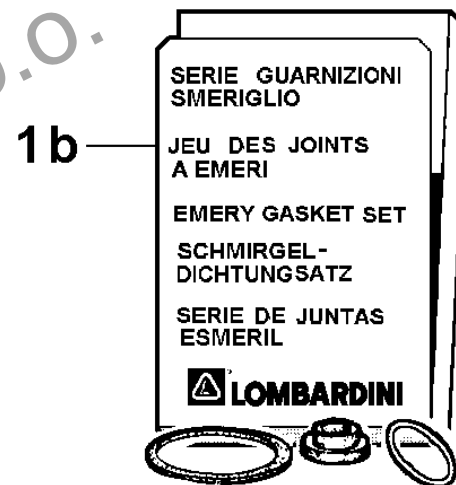
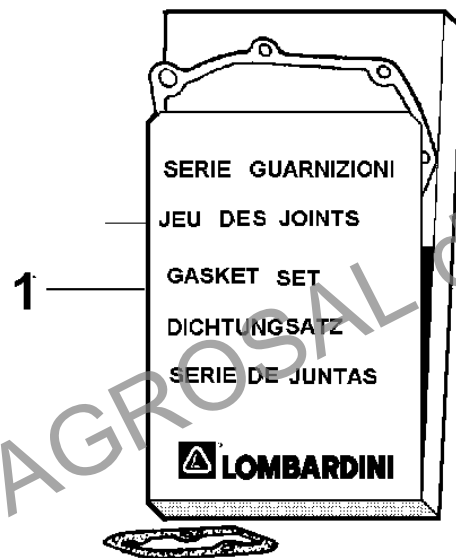

**LOMBARDINI**

A KOHLER COMPANY

Group: 8LD

Engine: 8LD 600-2 Drawing: M

STARTING

POS.	CODE	DESCRIPTION	Qty
1	<----->	switch cover	0
2	2900.110	dashboard 2 lights	1
3	7625.092	washer diam. 6,5	1
4	1760.005	bolt M 6 X 1 X 16	1
5	<----->	angle bracket	0
6	7565.007	washer diam. 8	1
7	1770.002	bolt M 8 X 1,25 X 16	1
8	2471.006	collar	1
9	5400.060	rubber sheathing	1
10	1770.001	bolt M 8 X 1,25 X 12	1
11	7625.010	washer diam. 8	1
12	4055.045	rope starting	1
13	<----->	lampe-socket - no longer avail.	0
14	7625.092	washer diam. 6,5	1
16	3617.020	clamp	1
17	3617.024	clamp	1
18	1157.158	volt.alternator 12V 14A - 3 wires	1
19	2145.014	regulator cap	1
20	6740.153	inlet regul.Saprisa	1
20	6740.154	inlet regul.Ducati	1
21	7362.228	voltage regulator. 12V 14/26A-6 contacts for alternator 3 wires	1
22	5175.162	lamp 12V	2
23	5041.020	key switch	1
24	7625.092	washer diam. 6,5	1
25	<----->	angle bracket	0
26	3240.019	nut M 8 alpha brass	1
27	3617.024	clamp	1
28	6491.005	pipe elbow	1
29	7625.061	washer diam. 8,4	2
30	<----->	switch cover	0
32	1760.005	bolt M 6 X 1 X 16	1
33	6491.013	pipe elbow	1
34	6745.050	oil switch 0,3 bar (M 12)	1
35	4670.014	copper gasket diam.12	1
36	5840.224	starting motor 12V 1,7KW	1
37	3240.066	nut M 10	2
38	7565.011	washer diam.10	2
39	6800.004	stud M 10 X 20 (35)	1
40	9730.046	screw M 10 X 35	1
41	9732.092	screw M 8 X 18	2

M

8LD

