

1.1.1 Componenti per rimorchi

Components for trailer

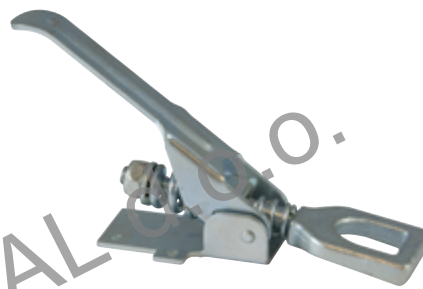

Ricambi & accessori per macchine agricole

SPARE PARTS & ACCESSORIES FOR AGRICULTURAL MACHINE

Tutti gli articoli della presente sezione, prodotti da AMA SPA e/o da terzi per conto di AMA, sono adattabili ("non originali") alle marche indicate ai sensi di quanto previsto dal REG. CE n. 1400/2002. I diritti sui marchi citati appartengono ai legittimi proprietari ed il loro uso ha l'esclusiva finalità di consentire all'utilizzatore la comparazione dei diversi prodotti. All items of this section, manufactured by AMA SPA and/or any third party on behalf of AMA, are adaptable ("non-original") to the brands listed under the provisions of the REG. CE n. 1400/2002. The rights on the trademarks belong to their respective owners and their usage is only aimed to allow the user to compare different products.

OCCHIONI GIREVOLI PER TIMONE

ANNEAUX TOURNANTS

TOWING EYES

DREHBARE ZUGÖSEN

ARGOLLA DE ENGANCHE GIRATORIO

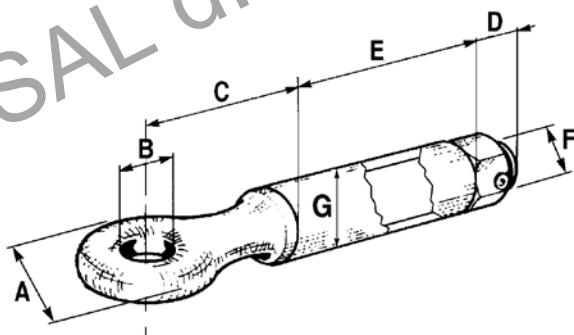

Art./Ref.	A mm	B mm	C mm	D mm	E mm	F mm	G mm	Massa trainabile/ Towable max load	Carico verticale/ Vertical load	Carico dinamico/ Dynamic load	Note/Note
00575	84	29	100	30	109	M24	42	3 t	200 daN	-	Non omologato/Not certified
01977	84	30	98		109		-	-	-	-	Grezzo, senza bussola girevole, non omologato / Rough, without swivel nut, not certified
00576	104	45	96	24	150	M30	51	6 t	-	1100 daN	Vecchia omologazione Cat. E leggero/ Old certification Cat. E light/
00577	105	45	98	33	146.5	M33	63	6 t	-	2300 daN	vecchia omologazione cat. E medio DGM-RA 988/ old certification cat. E medium DGM-RA 988
00578	112	45	98	33	146.5	M33	63	12 t	-	2090 daN	vecchia omologazione cat. F DGM-RA 987/ old certification cat. F DGM-RA 987
01120	131	52	110	60	150	M42	82	17 t	3000 daN	-	non omologato/not certified
02752	122	50,8	90	33	135	M33	60	14 t	1700 daN	-	tipo Francia/France type
02716	95	35	110	33	145	M33	60	6 t	-	-	nuova omologazione cat. E DGM-RA 1398/ new certification cat. E DGM-RA 1398
02726	62	22	90	24	110	M24	42	3 t	250 daN	1000 daN	nuova omologazione cat. E1 DGM-RA 1483 3t V0,25/ new certification cat. E1 DGM-RA 1483 3t V0,25
73050	95	35	110	26	145	M33	60	6 t	500 daN	3000 daN	Omologazione Cat. E2 DGM-RA 1408/ Certification Cat. E2 DGM-RA 1408
02728	95	35	110	26	145	M33	60	6 t	1500 daN	4500 daN	nuova omologazione cat. E3 DGM-RA 1407/ new certification cat. E3 DGM-RA 1407
73051	109	45	130	33	150	M33	63.5	12 t	-	-	Omologazione Cat. F DGM-RA 1399/ Omologation Cat. F DGM-RA 1399
02751	120	50	150	36	145	M36	70	14 t	2000 daN	5050 daN	nuova omologazione cat. F2 F2DGM-RA 1408 14t V2/ new certification cat. F2DGM-RA 1408 14t V2
81052	120	50	150	39	150	M39	76	14 t	2000 daN	5750 daN	Omologazione. F2 DGM-RA 1408/ Certification F2 DGM-RA 1408
02735	152	68	170	39	150	M39	76	20 t	-	-	nuova omologazione cat. F1DGM-RA 1400 20t V0/ new certification cat. F1DGM-RA 1400 20t V0
02769	160	76.2	190	48	170	M45x3	89	20 t	2500 daN	8800 daN	nuova omologazione cat. F3 DGM-RA 1700/ new certification cat. F3 DGM-RA 1700
81051	152	68	170	45	170	M45x3	89	20 t	2500 daN	9200 daN	Omologazione Cat. F3 DGM-RA 3*0240/ Omologation Cat. F3 DGM-RA 3*0240

OCCHIONE "GERMANIA"

ANNEAU "GERMANIA"
 "GERMANY" TOWING EYE
 "GERMANIA" ZUGÖSE
 ARGOLLA DE ENGANCHE "GERMANIA"

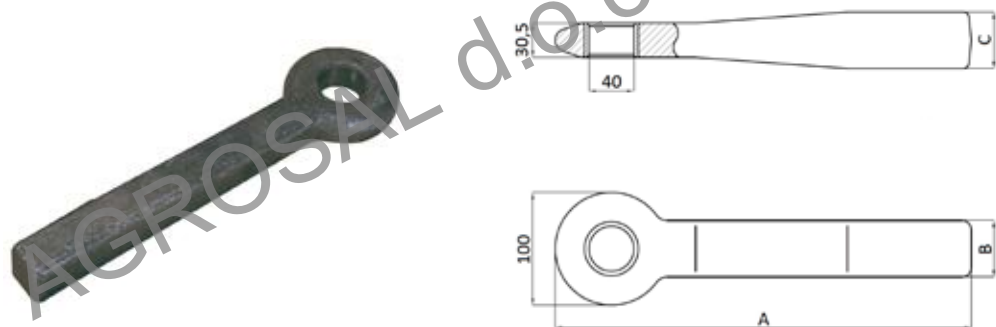

Art./Ref.	A mm	B mm	C mm	Massa trainabile/Towable max load	Carico verticale/Vertical load
00537	380	40	40	3 t	450 daN
00539	370	50	50	7 t	1000 daN
00547	380	55	65	10 t	1450 daN

OCCHIONE "INGLESE"

ANNEAU "INGLESE"
 "ENGLISH" TOWING EYE
 "INGLESE" ZUGÖSE
 ARGOLLA DE ENGANCHE "INGLESE"

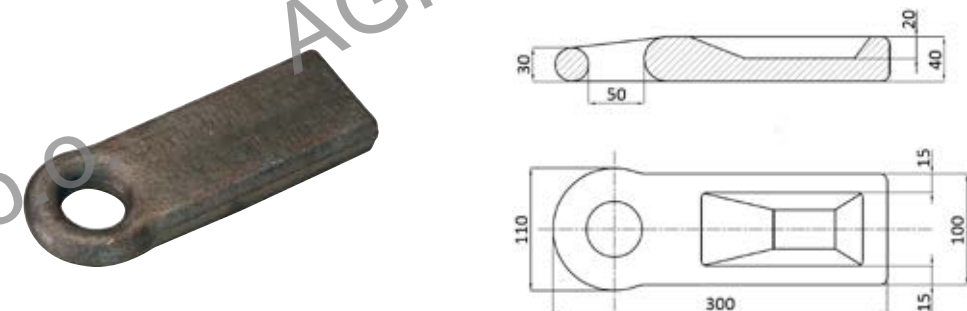

Art./Ref.	Massa trainabile/Towable max load	Carico verticale/Vertical load
10529	20 t	2300 daN

OCCHIONE "INGLESE" LEGGERO

ANNEAU "INGLESE" LÉGER
 "ENGLISH" LIGHT TOWING EYE
 "INGLESE" ZUGÖSE LEICHTGEWICHT
 ARGOLLA DE ENGANCHE LIGERO "INGLESE"



Art./Ref.	Massa trainabile/Towable max load	Carico verticale/Vertical load
88889	20 t	1500 daN

OCCHIONE "FRANCIA"

ANNEAU "FRANCIA"
 "FRANCE" TOWING EYE
 "FRANCIA" ZUGÖSE
 ARGOLLA DE ENGANCHE "FRANCIA"

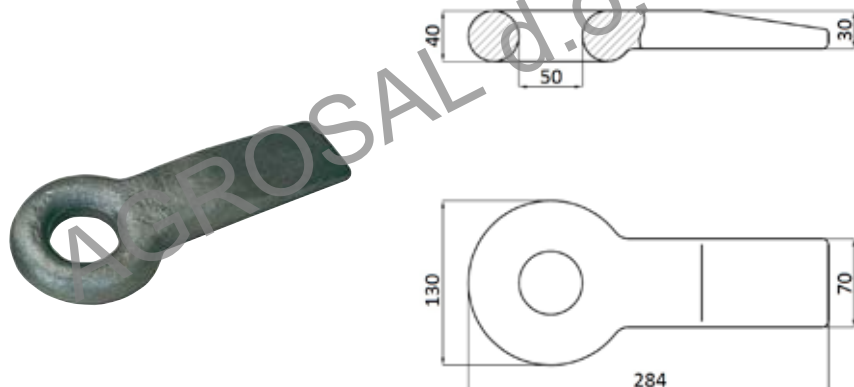

Art./Ref.	Massa trainabile/Towable max load	Carico verticale/Vertical load
00535	25 t	1100 daN

OCCHIONE "BELGIO"

ANNEAU "BELGIO"
 "BELGIUM" TOWING EYE
 "BELGIO" ZUGÖSE
 ARGOLLA DE ENGANCHE "BELGIO"

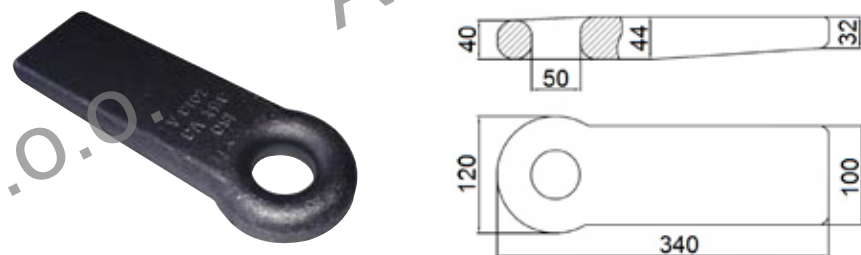

Art./Ref.	Massa trainabile/Towable max load	Carico verticale/Vertical load
88890	35 t	3000 daN

OCCHIONE "BELGIO" LEGGERO

ANNEAU "BELGIO" LÉGER
 "BELGIUM" LIGHT TOWING EYE
 "BELGIO" ZUGÖSE LEICHTGEWICHT
 ARGOLLA DE ENGANCHE LIGERO "BELGIO"

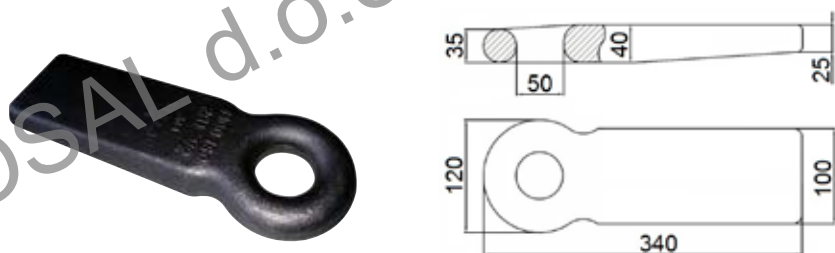

Art./Ref.	Massa trainabile/Towable max load	Carico verticale/Vertical load
88891	28 t	2000 daN

OCCHIONI FLANGIATI

ANNEAUX A FLASQUE

WELDABLE PLATE

ZUGÖSEN MIT FLANSCHEN

LASTRA SOLDABL

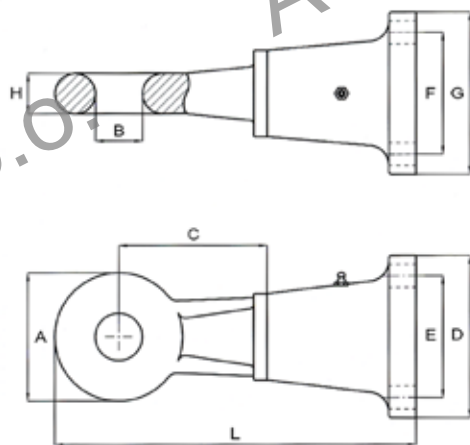

Art./ Ref.	Pos.	Diametro vite/ Screw diameter	A mm	B mm	C mm	D mm	E mm	F mm	G mm	H mm	L mm	Massa trainabile/ Towable max load	Carico verticale/ Vertical load	Note/Note
88892	1	M16	95	35	110	120	90	90	120	30	268	6 t	1500 daN	Omologazione 3*0250 - cat. E3/Certification 3*0250 cat. E3/
88893	2	M16	95	35	110	132	100	110	142	30	270	6 t	1500 daN	Omologazione 3*0250 - cat. E3 /Certification 3*0250 - cat. E3/
88894	3	M22	152	68	170	154	100	110	154	42	405	20 t	0	Omologazione 3*0212 - cat. F1 /Certification 3*0212 - cat. F1/
88895	3	M22	120	50	150	154	100	110	154	35	369	14 t	2000 daN	Omologazione 3*0213 - cat. F2/Certification 3*0213 - cat. F2/
88896	4	M22	152	68	170	154	100	110	154	42	405	20 t	2500 daN	Omologazione 3*0214 - cat. F3/Certification 3*0214 - cat. F3 /
88897	5	M22	160	76,2	190	154	100	110	154	42	429	20 t	2500 daN	Omologazione 3*0215 - cat. F3/Certification 3*0215 - cat. F3/
88898	5	M20	152	68	170	200	145	145	200	42	403	20 t	2500 daN	Omologazione 3*0252 - cat. F3/Certification 3*0252 - cat. F3/
88899	6	M20	160	76,2	190	200	145	145	200	42	427	20 t	2500 daN	Omologazione 3*0251 - cat. F3/Certification 3*0251 - cat. F3/
88900	7	M16	120	50	90	132	100	110	142	35	262	14 t	1700 daN	Tipo Francia/Francia type
88901	7	M16	120	50	90	132	100	110	142	35	262	20 t	2000 daN	Tipo Francia/Type Francia
88902	7	M22	126	50,8	110	154	100	110	154	41	332	28 t	2600 daN	Non omologato/Not certified
88903	7	M22	122	50,8	110	154	100	110	154	35	330	30 t	3500 daN	Non omologato/Not certified
88904	7	M22	126	50,8	110	154	100	110	154	41	332	38 t	4500 daN	Non omologato/Not certified
88905	8	M20	122	50,8	110	200	145	145	200	35	328	30 t	3500 daN	Non omologato/Not certified
88906	9	M20	126	50,8	110	200	145	145	200	41	330	38 t	4500 daN	Non omologato/Not certified

PIASTRA A SALDARE

PLAQUES A SOUDER

PLATE WELDING

ANSCHWEISSPLATTE

PLACA DE SOLDADURA

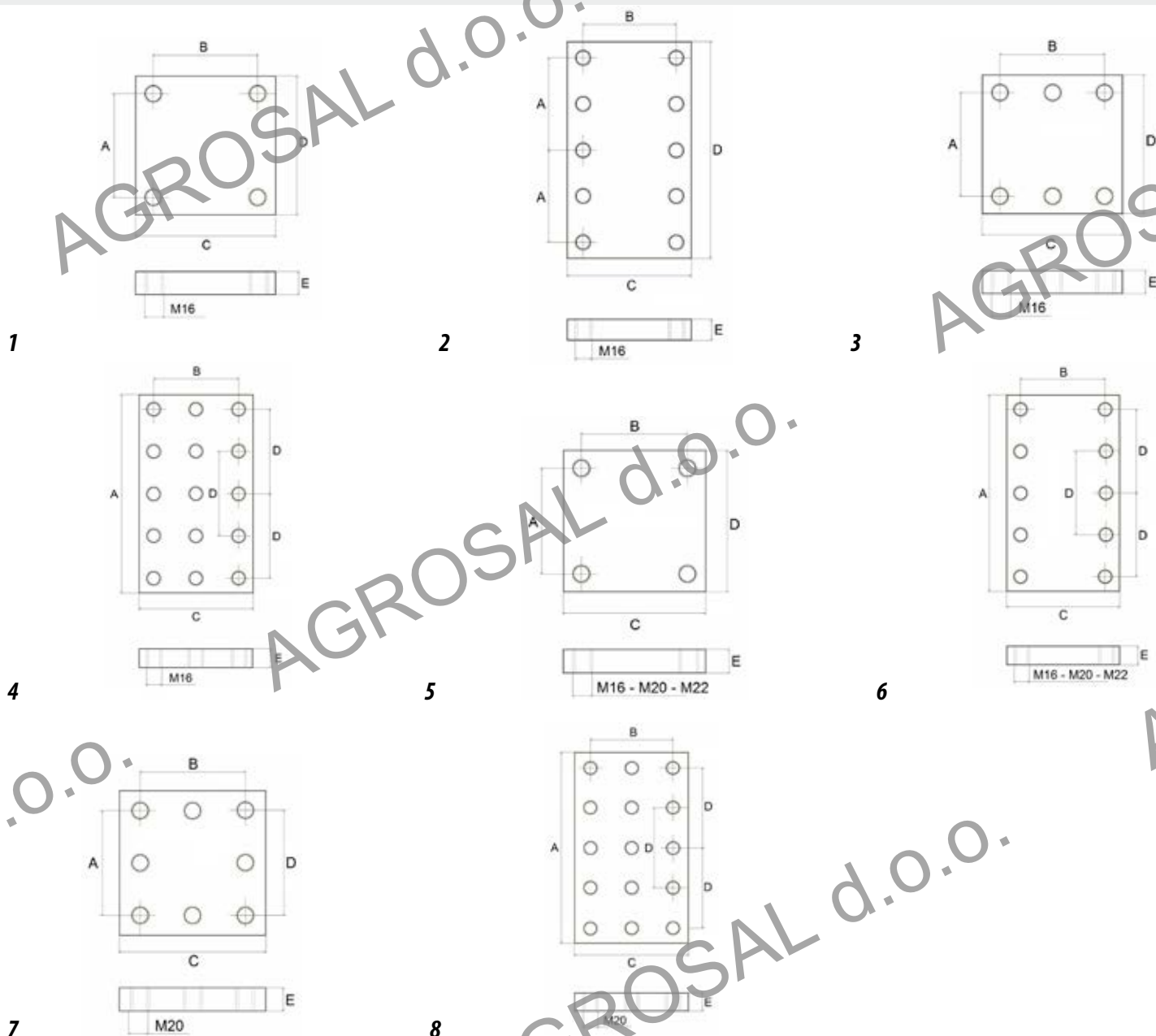

Art./Ref.	Pos.	Diametro vite/Screw diameter	A mm	B mm	C mm	D mm	E mm	Tipo/Type	Note/Note
88907	1	M16	90	90	130	130	20	4 fori	per art. 88892/for item 88892
88908	2	M16	90	90	130	220	20	10 fori	per art. 88892/for item 88892
88909	3	M16	110	100	160	160	30	6 fori	per art. 88900 - 88901 - 88893/for items 88900 - 88901 - 88893
88910	4	M16	270	100	160	110	30	15 fori	per art. 88900 - 88901 - 88893/for items 88900 - 88901 - 88893
88911	5	M22	110	100	160	160	30	4 fori	per art. 88894 - 88895 - 88896 - 88897 - 88902 - 88903 - 88904 /per art. 88894 - 88895 - 88896 - 88897 - 88902 - 88903 - 88904 /for item 88894 - 88895 - 88896 - 88897 - 88902 - 88903 - 88904/per art. 88894 - 88895 - 88896 - 88897 - 88902 - 88903 - 88904/per art. 88894 - 88895 - 88896 - 88897 - 88902 - 88903 - 88904
88912	6	M22	270	100	160	110	30	10 fori	per art. 88894 - 88895 - 88896 - 88897 - 88902 - 88903 - 88904 /per art. 88894 - 88895 - 88896 - 88897 - 88902 - 88903 - 88904/per art. 88894 - 88895 - 88896 - 88897 - 88902 - 88903 - 88904/per art. 88894 - 88895 - 88896 - 88897 - 88902 - 88903 - 88904
88913	7	M20	200	145	200	145	30	8 fori	per art. 88898 - 88899 - 88905 - 88906/for items 88898 - 88899 - 88905 - 88906
88914	8	M20	345	145	160	145	30	15 fori	per art. 88898 - 88899 - 88905 - 88906/per art. 88898 - 88899 - 88905 - 88906/for items 88898 - 88899 - 88905 - 88906/per art. 88898 - 88899 - 88905 - 88906/per art. 88898 - 88899 - 88905 - 88906

GANCI DI TRAINO PER AUTOCARRI

CROCHETS POUR CAMIONS
HOOK FOR TRUCKS
SEIL HAKEN
GANCHO DE TIPO



Note: Solo per uso agricolo
Notes: Only for agricultural use

Art./Ref.	Tipo/Type	A mm	B mm	C mm	D mm	E mm
02056	Leggero	71	78	27	60	13
02057	Medio	100	92	30	72	17

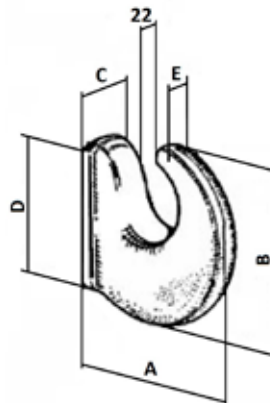

GANCIO TRAINO

CHAPES D'ATTELAGE A BROCHE
TOWING HITCHES
ANHÄNGERKUPPLUNG
GANCHO DE TIRO



Max carico statico
Max static load

1500 Kg

3000 Kg

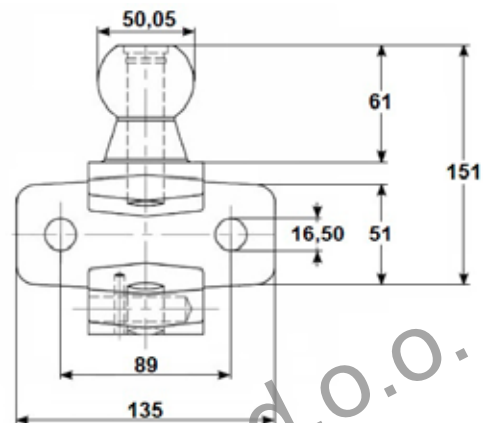

Note: Solo per uso agricolo
Notes: Only for agricultural use

Art./Ref.
39886

GANCIO TRAINO SUPER

CHAPES D'ATTELAGE A BROCHE "SUPER"
TOWING HITCHES
ANHÄNGERKUPPLUNG "SUPER"
GANCHO DE TIRO SUPER



Max carico statico
Max static load

3500 Kg

3500 Kg

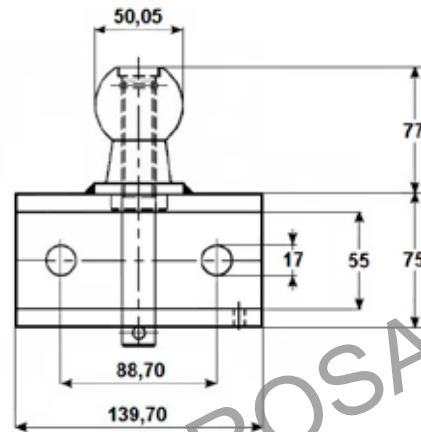

Note: Solo per uso agricolo
Notes: Only for agricultural use

Art./Ref.
39885

GANCIO TRAINO FISSO

CHAPES D'ATTELAGE FIXE
FIXED TOWING HITCH
FESTE ANHÄNGERKUPPLUNG
GANCHO DE TIRO FIJO



Note: Solo per uso agricolo
Notes: Only for agricultural use

Art./Ref.
02740

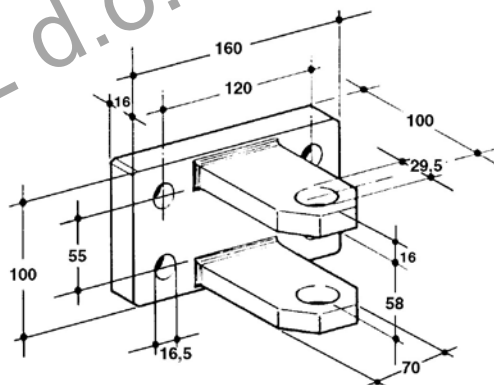
GANCIO TRAINO

CHAPE D'ATTELAGE A BROCHE
TOWING HITCH
ANHÄNGERKUPPLUNG
GANCHO DE TIRO



Note: Massa trainabile: 6000 Kg - Carico verticale max: 1500 daN
Notes: Towable max load: 6000 Kg - Max vertical load: 1500 daN

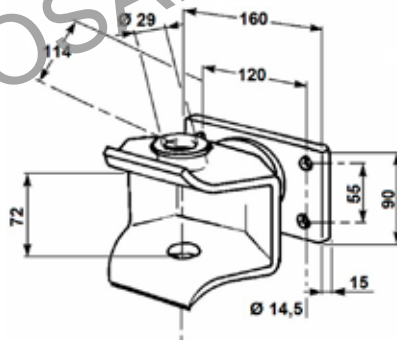

Art./Ref.	Tipo/Type	Note/Note
00257	Girevole	Cat. "C" - Spina art. 00259 non inclusa - Omologazione IGM-GA 276-C/Cat. "C" - Pin art. 00259 not included - Omologation IGM-GA 276-C
15924	Fisso	Cat. "B" - Spina art. 00259 inclusa - Omologazione DGM-GA 806 -B/Cat. "B" - Pin art. 00259 included - Omologation DGM-GA 806-B

SPINA AUTOMATICA

BROCHE AUTOMATIQUE
AUTOMATIC PIN
AUTOMATISCHER KUPPLUNGSBOLZEN
PERNO AUTOMÁTICO



Note: Per art. 02257 - 15924
Notes: For item 02257 - 15924

Art./Ref.
00259

GANCIO TRAINO CUNA C

CHAPE D'ATTELAGE A BROCHÉ CUNA C
 CUNA C TOWING HITCH
 ANHÄNGERKUPPLUNG CUNA C
 GANCHO DE TIRO CUNA C

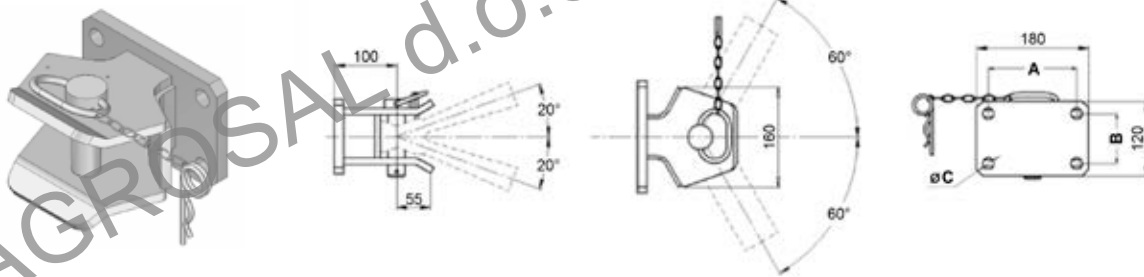

Note: Omologazione DGM*3*0225 GA / EU e3 00-3049, Ø perno 28 mm con sistema shock absorber. Massa trainabile: 6000 Kg. Carico verticale max: 1500 daN

Notes: Homologation DGM*3*0225 GA / EU e3 00-3049, pin Ø 28 mm with shock absorber device. Towable max load: 6000 Kg. Max vertical load: 1500 daN

Art./Ref.	A mm	B mm	C mm
89027	140	80	18
85531	120	55	16

GANCIO TRAINO CUNA D2

CHAPE D'ATTELAGE A BROCHÉ CUNA D2
 CUNA D2 TOWING HITCH
 ANHÄNGERKUPPLUNG CUNA D2
 GANCHO DE TIRO CUNA D2

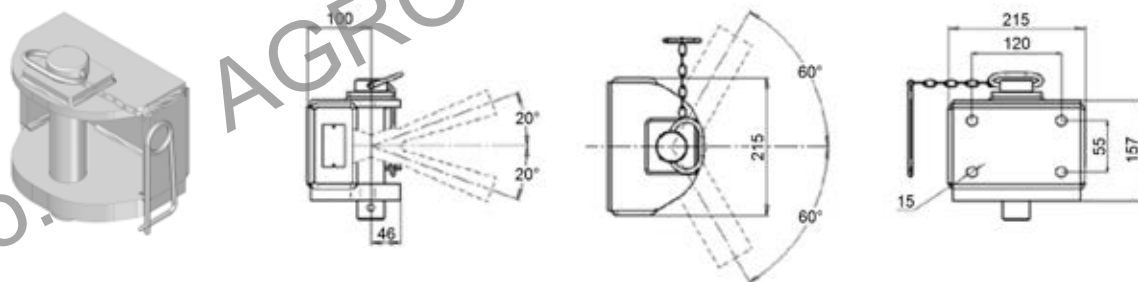

Note: Omologazione DGM*3*0255 GA / EU e3 00-3050, Ø perno 43 mm. Perno e coppiglia inclusi. Massa trainabile: 14000 Kg. Carico verticale max: 2000 daN

Notes: Homologation DGM*3*0255 GA / EU e3 00-3050, pin Ø 43 mm. Pin and split pin included. Towable max load: 14000 Kg. Max vertical load: 2000 daN

Art./Ref.
89028

GANCIO TRAINO CEE

CHAPE D'ATTELAGE A BROCHÉ CEE
 CEE TOWING HITCH
 ANHÄNGERKUPPLUNG CEE
 GANCHO DE TIRO CEE

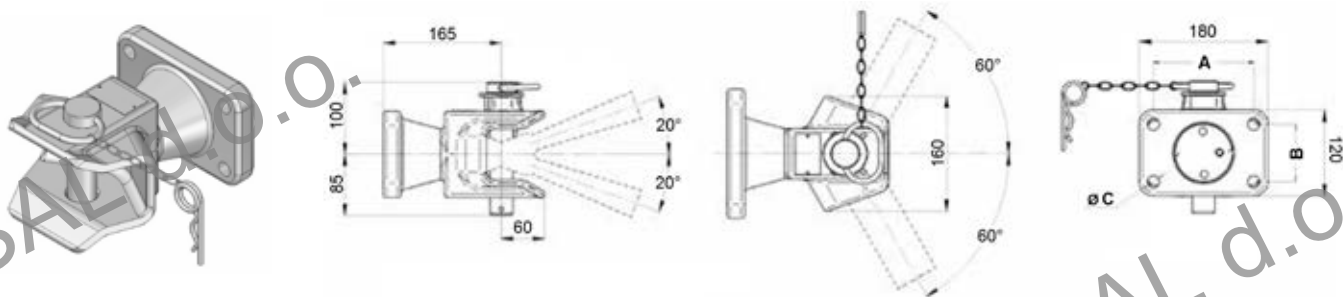

Note: Omologazione EU e11 00-3003, perno Ø 31 mm con dispositivo shock absorber per applicazioni alta velocità. Massa trainabile: 5000 Kg. Carico verticale max: 1500 daN

Notes: Homologation EU e11 00-3003, pin Ø 31 mm with shock absorber device for high speed application. Towable max load: 5000 Kg. Max vertical load: 1500 daN

Art./Ref.	A mm	B mm	C mm
89025	120	55	15
89026	140	80	17

GANCIO TRAINO CEE SEMIAUTOMATICO

CHAPE D'ATTELAGE A BROCHÉ CEE SEMI-AUTOMATIQUE
 SEMIAUTOMATIC CEE TOWING HITCH
 HALBAUTOMATISCHE ANHÄNGERKUPPLUNG CEE
 GANCHO DE TIRO CEE SEMIAUTOMÁTICO

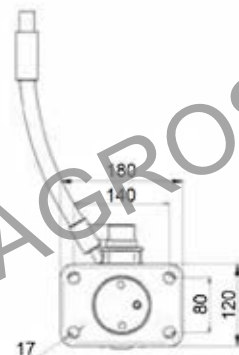
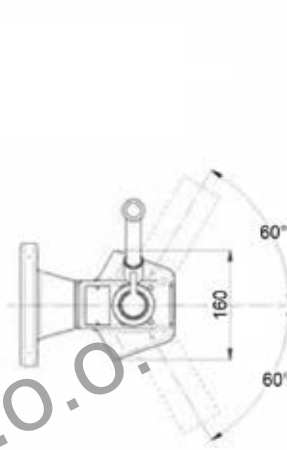
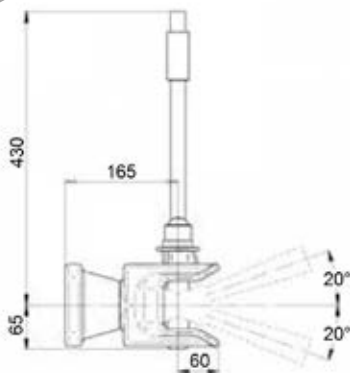
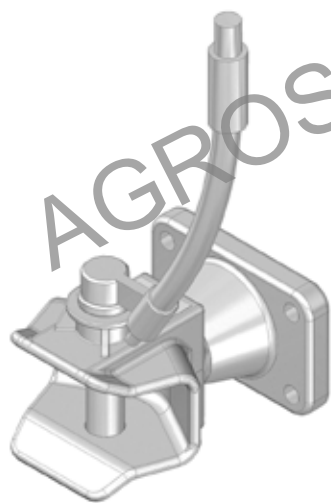

Note: Omologazione EU e11 00-3003, Ø perno 31 mm con dispositivo shock absorber per applicazioni alta velocità.

Notes: Homologation EU e11 00-3003, pin Ø 31 mm with shock absorber device for high speed application.

Art./Ref.	Massa trainabile/Towable max load	Carico verticale/Vertical load
89023	5000 Kg	1500 daN
89024	8000 Kg	2000 daN

LEVE A RICAMBIO PER GANCI 89023 E 89024

LEVIERS A RECHANGE POUR CROCHETS 89023 ET 89024
 SPARE LEVER FOR HOOK 89023 AND 89024
 ERSATZHEBEL FÜR ANHÄNGERKUPPLUNGEN 89023 UND 89024
 PALANCA DE REPUESTO POR ENGANCHE 89023 Y 89024

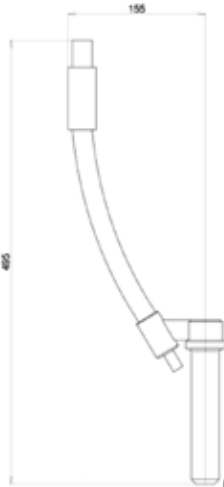
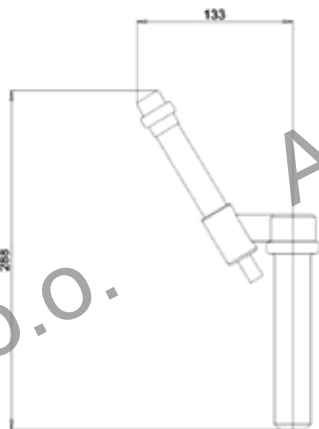

Note: Per ganci art. 89023 - 89024

Notes: For towing hitch item 89023 - 89024

Art./Ref.
89029
89030

GANCIO TRAINO CEE AUTOMATICO

CHAPE D'ATTELAGE A BROCHÉ CEE AUTOMATIQUE
 AUTOMATIC CEE TOWING HITCH
 AUTOMATISCHE ANHÄNGERKUPPLUNG CEE
 GANCHO DE TIRO CEE AUTOMÁTICO

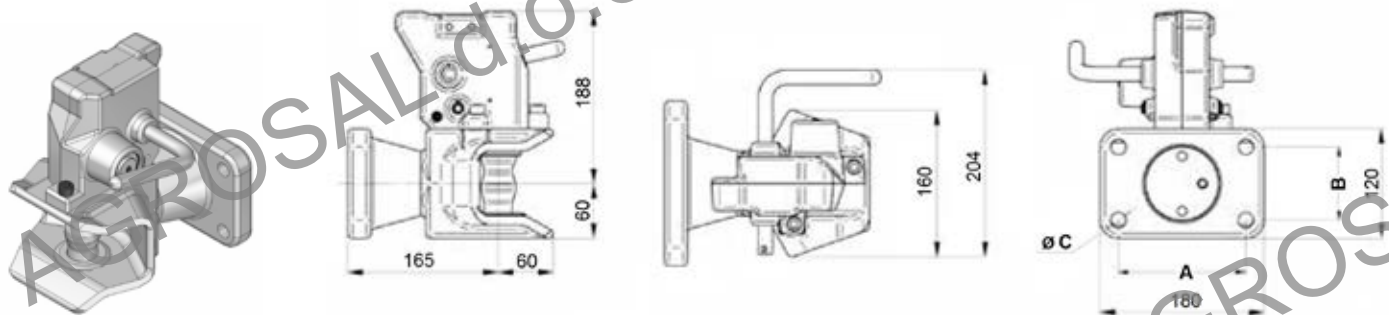

Note: Omologazione EU e11 00-3002, Ø perno 38 mm con dispositivo shock absorber per alta velocità. Massa trainabile: 5000 Kg. Carico verticale max: 1500 daN
Notes: Homologation EU e11 00-3002, pin Ø 38 mm with shock absorber device for high speed application. Towable max load: 5000 Kg. Max vertical load: 1500 daN

Art./Ref.	A mm	B mm	C mm
89021	120	55	15
89022	140	80	17

GIUNTI A SFERA CON PULSANTE

JOINTS A SPHERE AVEC POUSSOIR
 SPHERE JOINT WITH BUTTON
 ANHÄNGE-KUPPLUNGEN MIT KNOPF
 JUNTAS ESFERICAS CON INTERRUPTOR

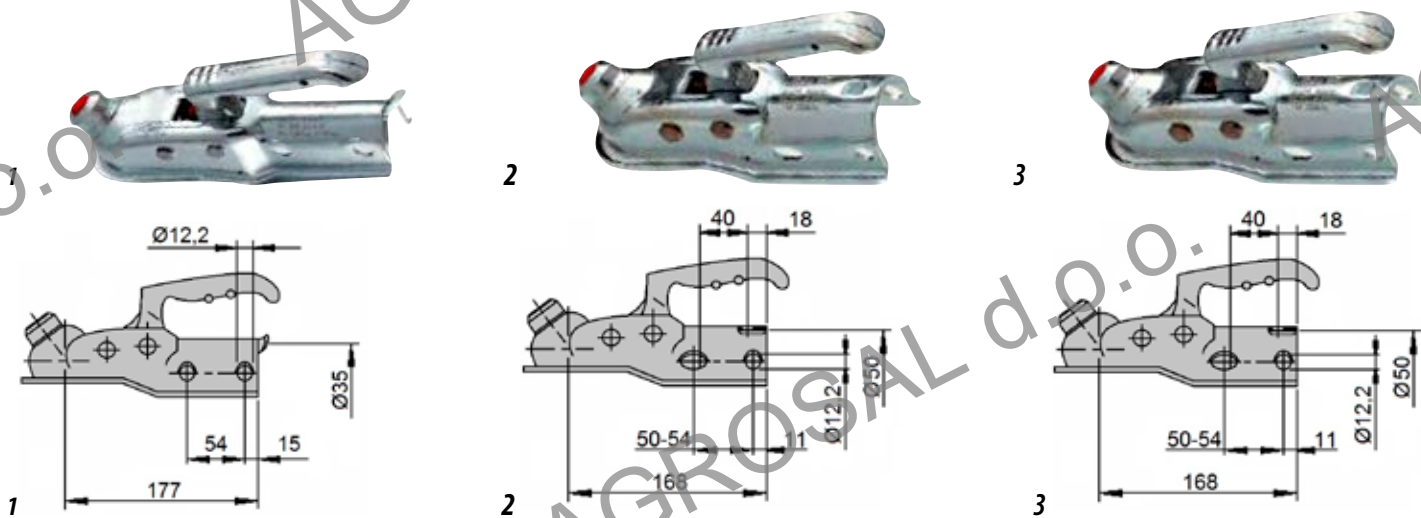

Note: I giunti sono provvisti di indicatore di sicurezza (Fig.1). Il giunto è stato agganciato correttamente quando si evidenzia il cilindro verde.
Notes: Joints are provided with security indicator (Fig.1). The joint has been hitched up correctly when the green cylinder is visible.

Art./Ref.	Pos.	Portata Kg/Portata Kg	Note/Note
75268	1	1600	Ø 35 Carico d'appoggio 120 kg Coppia serraggio 86 Nm/Ø 35 Support load 120 kg Tightening torque 86 Nm
75269	2	1600	Ø 50 Carico d'appoggio 120 kg Coppia serraggio 86 Nm/Ø 50 Support load 120 kg Tightening torque 86 Nm
75270	3	3000 2300 (a croce)	Ø 50 Carico d'appoggio 120 kg Coppia serraggio 86 Nm/Ø 50 Support load 120 kg Tightening torque 86 Nm

TESTINE AGGANCO TRAINI

CHAPE D'ATTELAGE TIRAGE
TRAILER HITCH COUPLINGS
ANHÄNGE-KUPPLUNG
CABEZALE DE ENGANCHE

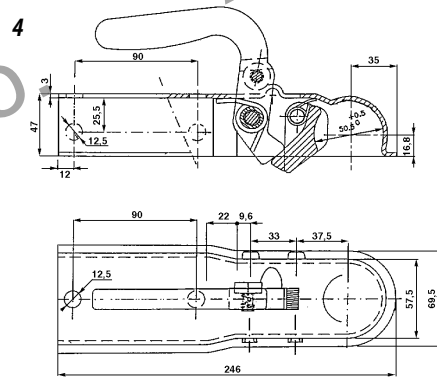
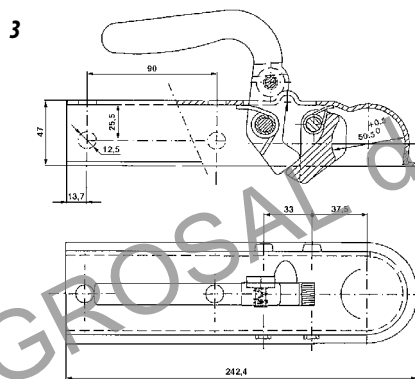
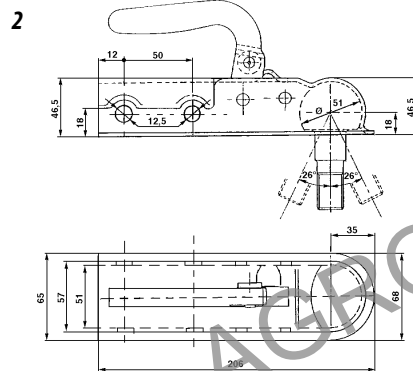
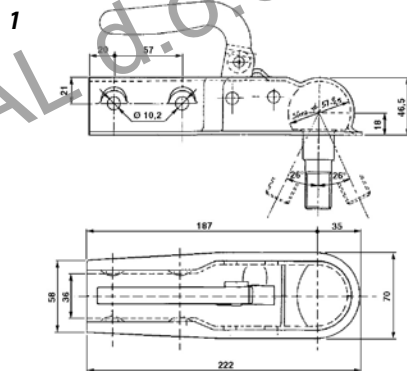

Art./Ref.	Pos.	Massa trainabile/Towable max load	Note/Note
11772	1	3500	Attacco posteriore Ø,50mm / Rear connection Ø,50 mm Attacco anteriore Ø,50 / Front connection Ø,50mm Omologazione DGM 51252/R1 / Omologation DGM 51252/R1
11773	2	3500	Attacco posteriore Ø,60mm / Rear connection Ø,60 mm Attacco anteriore Ø,50 / Front connection Ø,50mm Omologazione DGM 51254/R1 / Omologation DGM 51254/R1
11774	3	1000	Attacco posteriore Ø,50mm / Rear connection Ø,50 mm Attacco anteriore Ø,50 / Front connection Ø,50mm Omologazione DGM 51252/R1 / Omologation DGM 51252/R1
11775	4	1000	Attacco posteriore Ø,60mm / Rear connection Ø,60 mm Attacco anteriore Ø,50 / Front connection Ø,50mm Omologazione DGM 51254/R1 / Omologation DGM 51254/R1

ATTACCHI A SFERA PER RIMORCHI 50 MM

TOWBALL
BOULE D'ATTELAGE
KUPPLUNGSKUGEL
BOLAS DE ENGANCHE

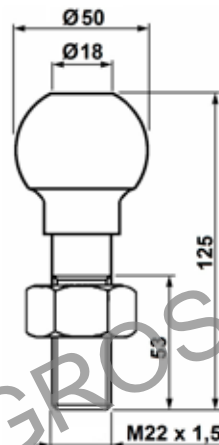

Note: Applicabili a tutti i modelli di testine d'aggancio (Art. 11772 - 11773 - 11774 - 11775). Solo per uso agricolo.
Notes: Suitable for all types of trailer hitch couplings (item 11772 - 11773 - 11774 - 11775). Only for agricultural use.

Art./Ref.	Massa trainabile/Towable max load
11776	3500 Kg

PERNO TRAINO A SFERA

AXE ATTELAGE A SPHERE
 BALL TOWING PIN
 KUPPLUNGSKUGEL MIT VORSTECKER
 PERNO TIRO CON RÓTULA

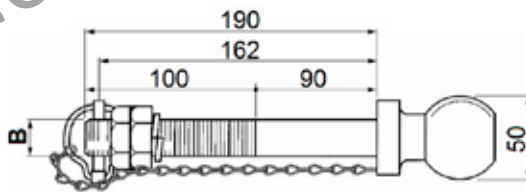

Note: Solo per uso agricolo.
Notes: Only for agricultural use.

Art./Ref.	B mm	B inch
09598	22	7/8"
09599	25	1"

LEVA FRENO A MANO

LEVIER FREIN A MAIN
 HAND BRAKE LEVER
 HANDBREMSHEBEL
 PALANCA DE FRENO MANUAL

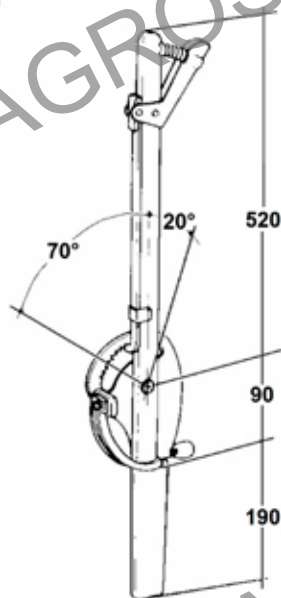

Art./Ref.
00570

SCATOLINA PER LEVA FRENO

BRIDE POUR LEVIER FREIN
 HAND BRAKE LEVER SUPPORT
 HALTERUNG FÜR HANDBREMSHEBEL
 SOPORTE PARA PALANCA DE FRENO

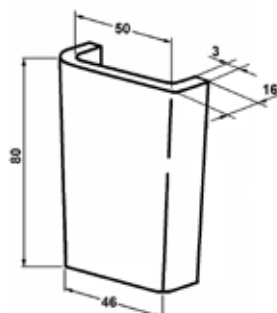
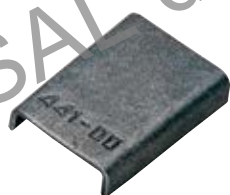

Art./Ref.
01197

LEVA FRENO PARCHEGGIO - DESTRA

LEVIER FREIN STATIONNEMENT - DROIT
 PARKING BRAKE LEVER - RIGHT
 HANDBREMSHEBEL - RECHTS
 PALANCA FRENO APARCAMIENTO - DERECHA

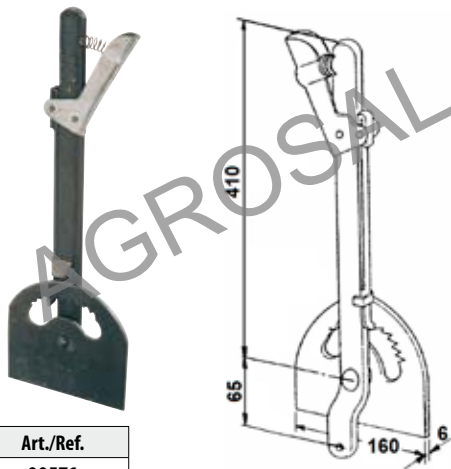

Art./Ref.
00571

LEVE FRENO A MANO TIPO FRANCIA

LEVIERS FREIN A MAIN TYPE FRANCE
 HAND BRAKE LEVERS FRENCH TYPE
 HANDBREMSHEBEL FRANKREICH TYP
 PALANCAS DE FRENO MANUAL TIPO FRANCIA

Note: Verniciata rossa
Notes: Red painted

Art./Ref.	A mm	B mm	C mm	Peso Kg/Weight Kg
88925	500	240	150	2,3
88926	590	265	200	2,6
88927	800	265	200	3,3

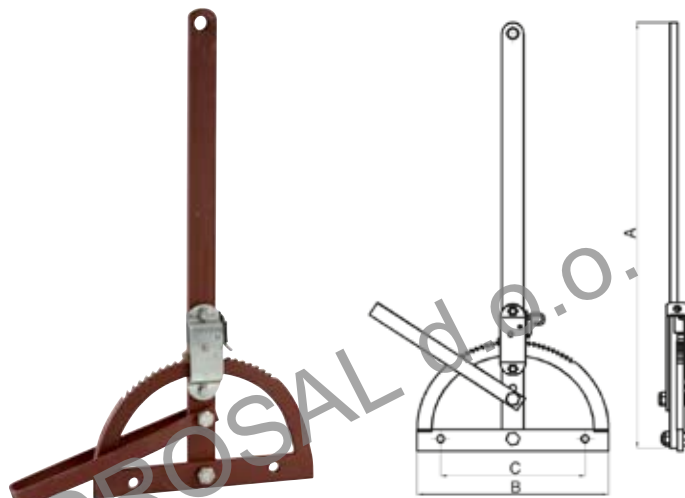
FRENO DI STAZIONAMENTO PER RIMORCHI

FREIN DE STATIONNEMENT REMORQUES
 PARKING BRAKE FOR TRAILERS
 PARKENBREMSE FÜR ANHÄNGER
 FRENO DE APARCAMIENTO PARA REMOLQUES

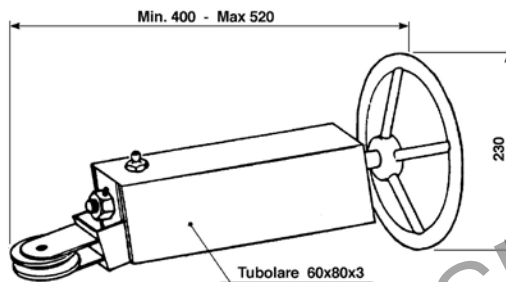

Art./Ref.
00010

FRENO A VITE CON RULLO

FREIN À VIS AVEC ROULEAU
 SPINDLE BRAKE WITH ROLLER
 SPINDELBREMSE MIT ROLLE
 FRENO DE HUSILLO CON RODILLO



Note: Verniciato nero.
Notes: Painted black.

Art./Ref.
59168

LEVA FRENO A MANO ADATTABILE A FIAT

LEVIER FREIN A MAIN TYPE FIAT
 HAND BRAKE LEVER FIAT TYPE
 HANDBREMSHEBEL TYP FIAT
 PALANCA DE FRENO MANUAL TIPO FIAT

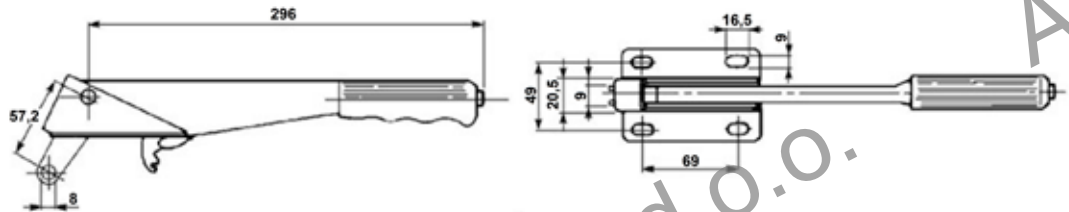

Note: Leva fornita completa di manopola e verniciata nera. RAPPORTO LEVA: 1 x 5,20
Notes: Black painted lever supplied with grip handle. LEVER RATIO: 1 x 5,20

Art./Ref.
12697

LEVA FRENO TIPO CORTO CON FORCELLA CHIUSA E CARRUCCOLA IN NYLON

LEVIER FREIN TYPE COURT AVEC FOURCHE FERMÉE ET POULIE EN NYLON
 BRAKE LEVER SHORT TYPE WITH NYLON PULLEY
 KURZER HANDBREMSHEBEL MIT NYLONROLLE
 PALANCA FRENO TIPO CORTO CON HORQUILLA CERRADA Y PLEA DE NYLON

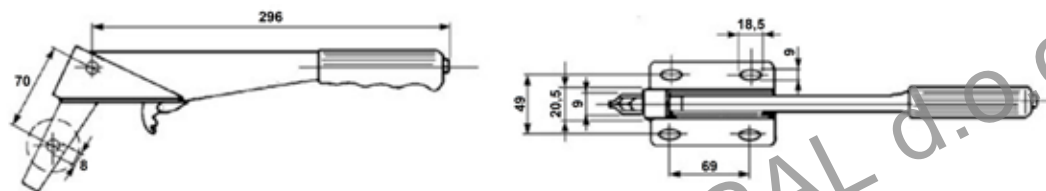

Note: Leva fornita completa di manopola e verniciata nera. RAPPORTO LEVA: 1 x 4,23
Notes: Black painted lever supplied with grip handle. LEVER RATIO: 1 x 4,23

Art./Ref.
12698

CARRUCOLA CON PERNO

POULIE AVEC PIVOT
PULLEY WITH PIN
NYLONROLLE MIT BOLZEN
POLEA CON PERNO

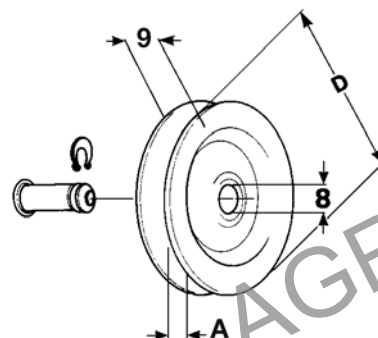

Art./Ref.	A mm	D mm	Tipo/Type	Brand	Applicazione/Application
00125	4	47,5	Nylon	A.M.A.	12698
00032	6	69,5	Acciaio	A.M.A.	12697

LEVE FRENO A MANO PER MULETTI

LEVIERS FREIN A MAIN POUR MACHINES INDUSTRIELLES
HAND BRAKE LEVERS FOR INDUSTRIAL MACHINES
HANDBREMSHEBEL FÜR HUBSTAPLER
PALANCAS FRENO MANUAL PARA CARRETILLAS ELEVADORAS

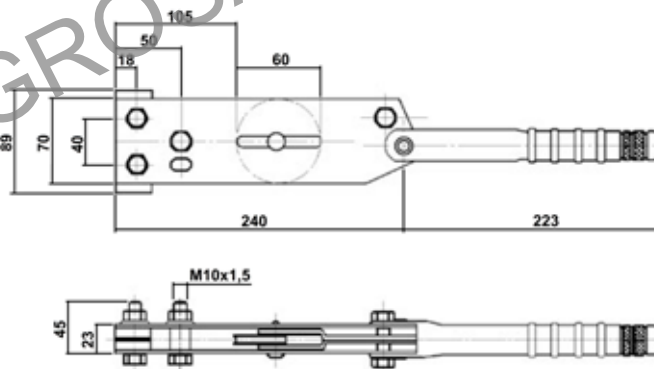

Note: Forza max applicabile alla leva: 200 N. Forza max applicabile al cavo: 3000 N. Corsa: 60mm

Notes: Max force on lever: 200 N. Max force on cable: 3000 N. Stroke: 60 mm

Art./Ref.	Tipo/Type
01395	Senza carrucola/Without pulley
01394	Carrucola acciaio/Steel pulley

LEVA FRENO A MANO ADATTABILE A ALKO

LEVIER FREIN A MAIN TYPE ALKO
HAND BRAKE LEVER ALKO TYPE
HANDBREMSHEBEL TYP ALKO
PALANCA DE FRENO MANUAL TIPO ALKO



Art./Ref.
00896

SUPPORTO PER LEVA FRENO

BRIDE POUR LEVIERS FREIN
HAND BRAKE LEVER SUPPORT
HALTER ZU HANDBREMSHEBEL
SOPORTE PARA PALANCA FRENO

Art./Ref.
00925



CAPOGUAINA

ARRETOIR POUR GAINES
SHEATH STOP
HÜLSE-SEILENDE
TOPE CHAPA DE PROTECCIÓN

Art./Ref.
00897



CAVO PER LEVA FRENO

CABLE POUR LEVIER FREIN
CABLE FOR BRAKE LEVER
BREMSSSEILZÜGE
CABLE PARA PALANCA FRENO

Art./Ref.	Tipo/Type	Lunghezza mm/Lenght mm
05626	Terminale a vite M10/Brake cable end screw M10	5000
05627	Terminale occhio Ø 12 mm/Brake cable end eye Ø 12 mm	5000
05628	Terminale a vite M12/Brake cable end screw M12	5000
05629	Terminale occhio Ø 10 mm/Brake cable end eye Ø 10 mm	7000
05630	Terminale a vite M10/Brake cable end screw M10	7000
05631	Terminale occhio Ø 12 mm/Brake cable end eye Ø 12 mm	7000
05632	Terminale a vite M12/Brake cable end screw M12	7000



CUNEI D'ARRESTO

COINS D'ARRET
STOP CHOCK
UNTERLEGKEIL
PUNTALES DE SUJECIÓN

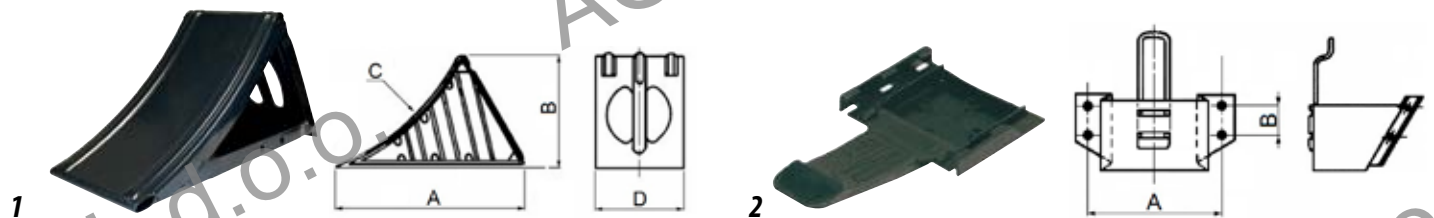

Art./Ref.	Pos.	A mm	B mm	C mm	D mm	Portata Kg/Portata Kg	Note/Note
05952	1	225	100	290	90	1500	No omologazione / Plastica/No homologation / Plastic
05954	1	320	150	360	120	1600	Omologato / Verniciato/Homologated / Varnished
05956	1	380	190	460	160	5000	Omologato / Verniciato/Homologated / Varnished
05958	1	470	230	600	200	6500	Omologato / Verniciato/Homologated / Varnished
05951	2	95	20	-	-	-	Supporto per art. 05952/Support for item 05952
05953	2	145	40	-	-	-	Supporto per art. 05954/Support for item 05954
05955	2	185	60	-	-	-	Supporto per art. 05956/Support for item 05956
05957	2	230	80	-	-	-	Supporto per art. 05958/Support for item 05958

CUNEI E SUPPORTI ADATTABILI A FIAT - FORD - NEW HOLLAND

COIN D'ARRET ET SUPPORT ADAPTABLE FIAT-FORD-NEW HOLLAND

BRAKE BLOCKS AND SUPPORT ADAPTABLE FIAT-FORD-NEW HOLLAND

BREMASKEIL UND HALTERUNG PASSEND ZU FIAT-FORD-NEW HOLLAND

BLOQUEO RUEDA Y SOPORTE ADAPTABLE FIAT-FORD-NEW HOLLAND



Art./Ref.	Descrizione/Description	Brand	Applicazione/Application	Rif. Orig./Orig. Ref.
17201	supporto cuneo/ support	FIAT	F100, F100DT, F110, F110DT, F115, F115DT, F120, F120DT, F130, F130DT, F140, F140DT, serie 90, SERIE 93, serie 94,	5115840
		FORD	3435, 3935, 4135, 4635, 4835, 5635, 6635, 8260,	
		NEW HOLLAND	L60, L65, L75, L85, L95, LB115, LB75, M100, M115, M135, M160, NH75TLB, NH85TLB, NH95TLB, TL100, TL70, L80, TL90, TM115, TM125, TM135, TM150, TM165, TN55, TN55D, TN55S, TN65, TN65D, TN65S, TN70, TN75, TN75D, TN75S	
17202	Cuneo d'arresto/ Brake block	FIAT	100.90-100.90 DT, 110.90-110.90 DT, 115.90-115.90 DT, 130.90-130.90 DT, 140.90-140.90 DT, 160.90-160.90 DT, 180.90-180.90 DT, 45.66-45.66 DT, 45.66S-45.66S DT, 50.66-50.66 DT, 50.66-60.66 DT, 50.66S-50.66S DT, 50.66S-50.66S DT, 55.46-55.46 DT, 55.56-55.56 DT, 55.66-55.66 DT, 55.66S-55.66S DT, 55.88-55.88 DT, 55.90-55.90 DT, 56.66S-56.66S DT, 60.46-60.46 DT, 60.56-60.56 DT, 60.66-60.66 DT, 60.66-60.66 DT, 60.66S-60.66S DT, 60.88-60.88 DT, 60.90-60.90 DT, 60.90-60.90 DT, 60.93-60.93 DT, 60.93-60.93 DT, 60.94-60.94 DT, 65.46-65.46 DT, 65.56-65.56 DT, 65.56-65.56 DT, 65.66-65.66 DT, 65.66S-65.66S DT, 65.88-65.88 DT, 65.90-65.90 DT, 65.93-65.93 DT, 65.94-65.94 DT, 70.56-70.56 DT, 70.66-70.66 DT, 70.66S-70.66S DT, 70.88-70.88 DT, 70.90-70.90 DT, 72.93-72.93 DT, 72.94-72.94 DT, 80.66-80.66 DT, 80.66S-80.66S DT, 80.88-80.88 DT, 80.90-80.90 DT, 82.93-82.93 DT, 82.94-82.94 DT, 85.90-85.90 DT, 85.90-85.90 DT, 88.93-88.93 DT, 88.94-88.94 DT, 90.90-90.90 DT, F100, F100 DT, F110, F110 DT, F115, F115 DT, F120, F120 DT, F130, F130 DT, F140, F140 DT,	5112736
		FORD	3435, 3935, 4135, 4635, 4835, 5635, 6635, 7635, 8160, 8260, 8360, 8560,	
		NEW HOLLAND	L60, L65, L75, L85, L95, LB115, LB115CP, LB75, LB75CP, LB85, LB90, LB95, M100, M115, M135, M160, NH75TLB, NH85TLB, NH95TLB, T4020V, T4030V, T4040N, T4040V, T4050N, T4050V, TL100, TL100A, TL55F, TL65, TL65A, TL65F, TL70, TL70A, TL75F, TL80, TL80A, TL90, TL90A, TM115, TM120, TM125, TM135, TM140, TM150, TM155, TM165, TM175, TM190, TN55, TN55D, TN55S, TN55V, TN60SA, TN60VA, TN65, TN65D, TN65N, TN65S, TN65V, TN70, TN70D, TN70DA, TN70F, TN70NA, TN70S, TN70SA, TN70VA, TN75, TN75A, TN75D, TN75FA, TN75N, TN75NA, TN75S, TN75SA, TN75V, TN75VA, TN80F, TN85FA, TN85SA, TN95F, TN95FA, TN95NA, TN95VA, TV140	

PIEDI D'APPOGGIO TELESCOPICI

BEQUILLE CRIC

TELESCOPIC PARKING JACK

ABSTELLSTÜTZE

PIE APOYO TELESCOPICO

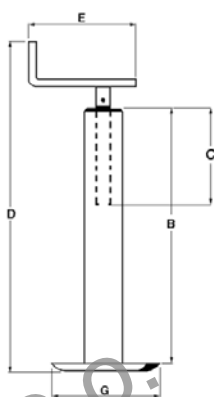

Art./Ref.	B mm	C mm	D mm	E mm	G mm	Sezione tubo mm/Hose section mm	Carico verticale/Vertical load	Note/Note
01058	385	210	532	192	95	40 x 40	200	Senza cuscinetto reggispira/without bearing
00500	400	250	528	192	160	50 x 50	300	Senza cuscinetto reggispira/without bearing
00502	470	255	620	192	160	50 x 50	300	Senza cuscinetto reggispira/without bearing
00503	570	255	708	192	160	50 x 50	500	Senza cuscinetto reggispira/without bearing
00506	460	255	610	213	160	60 x 60	600	Senza cuscinetto reggispira/without bearing
00507	570	255	710	213	160	60 x 60	600	Senza cuscinetto reggispira/without bearing
00508	495	300	610	213	160	70 x 70	1000	-
03958	600	400	740	213	160	70 x 70	1000	-
00351	695	500	810	213	220	70 x 70	1000	-
00509	500	300	615	213	220	80 x 80	1200	-

MOLLE FERMALEVA PER SERVOTIMONE

RESSORT FERMA-LEVE BRUT POUR BEQUILLES
 ROUGH SPRINGS GRIPS FOR PARKING JACKS
 BLOCKIERUNGSFEDER ROH FUER STUETZFUESSE
 MUELLE DE DETENCIÓN DE PALANCA DE APOYO

Note: Grezza

Notes: Rough

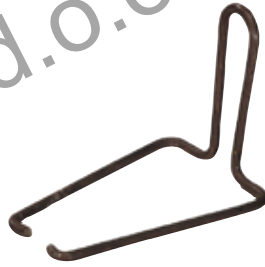

Art./Ref.	Sezione tubo mm/Hose section mm
17648	40 - 60
17649	70 - 80

STABILIZZATORE FISSO ZINCATO

STABILISATEUR FIXE ZINGUE
 GALVANISED FIXED STABILIZER
 STÜTZE VERZINKT FIX
 ESTABILIZADOR FIJO CINCADO



Art./Ref.	Sezione tubo mm/Hose section mm
15882	Ø 48 mm

PIEDE D'APPOGGIO CON ATTACCO REGOLABILE

BEQUILLE AVEC FIXATION REGLABLE
 PARKING JACK WITH ADJUSTABLE CONNECTION
 STÜTZFUSSE MIT REGULIERBAREM BEFESTIGUNGSTEIL
 PIE DE APOYO CON ENGANCHE AJUSTABLE

Note: Allungamento 330 mm - Carico verticale 4 ton

Notes: Extension 330 mm - Vertical load 4 ton

Art./Ref.	A mm	B mm	Sezione tubo mm/Hose section mm	Carico verticale/Vertical load
02430	125	470	60 x 60	600 Kg
02431	190	500	70 x 70	1000 Kg
02432	190	500	80 x 80	1200 Kg

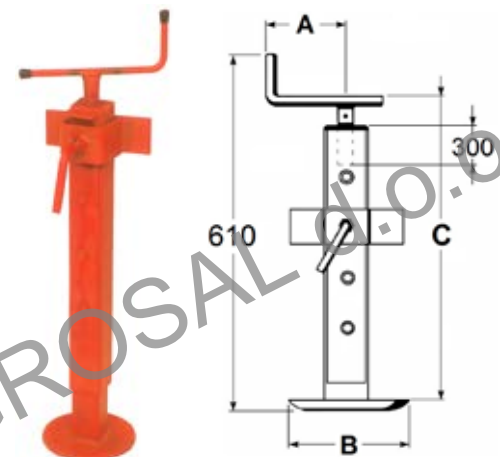

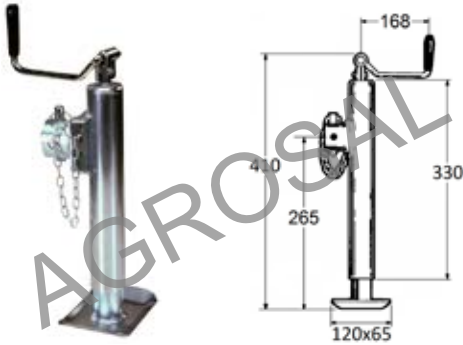
PIEDE D'APPOGGIO RIBALTABILE MONTAGGIO A TUBO
BEQUILLE BASCULANTE, FIXATION PAR TUBE
SWIVEL JACK, TUBE MOUNTING
KLAPPBARER STÜTZFUSS, ROHRANSCHLUSS
PIE DE APOYO BASCULANTE - MONTAJE POR TUBO

Art./Ref.	Sezione tubo mm/Hose section mm	Allungamento mm/Extension mm	Carico verticale/Vertical load
02434	57	250	1300 Kg

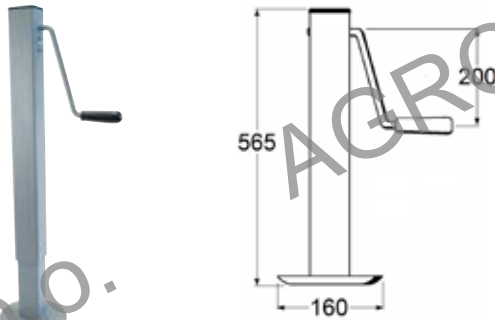
SERVOTIMONI CON MANOVELLA LATERALE
BEQUILLE AVEC MANIVELLE LATERALE
PARKING JACK WITH LATERAL HANDLE
STÜTZFUSS MIT SEITLICHER KURBEL
PIE DE APOYO CON MANIVELA LATERAL

Art./Ref.	Sezione tubo mm/Hose section mm	Allungamento mm/Extension mm	Carico verticale/Vertical load
01082	60 x 60	300	800 Kg

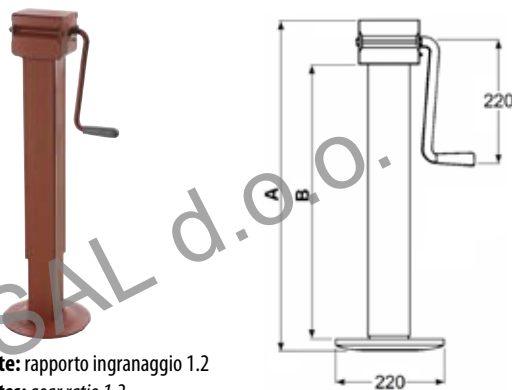
SERVOTIMONE CON MANOVELLA LATERALE
BEQUILLE AVEC MANIVELLE LATERALE
PARKING JACK WITH LATERAL HANDLE
STÜTZFUSS MIT SEITLICHER KURBEL
PIE DE APOYO CON MANIVELA LATERAL

Note: rapporto ingranaggio 1.2

Notes: gear ratio 1.2

Art./Ref.	A mm	B mm	Sezione tubo mm/Hose section mm	Allungamento mm/Extension mm	Carico verticale/Vertical load
01083	620	500	70 x 70	330	3000 Kg
01084	620	500	80 x 80	300	4000 Kg
17706	870	750	80 x 80	530	2800 Kg

SOLLEVATORE A TRE SFILATE PER RIMORCHI TANDEM, A DUE VELOCITÀ

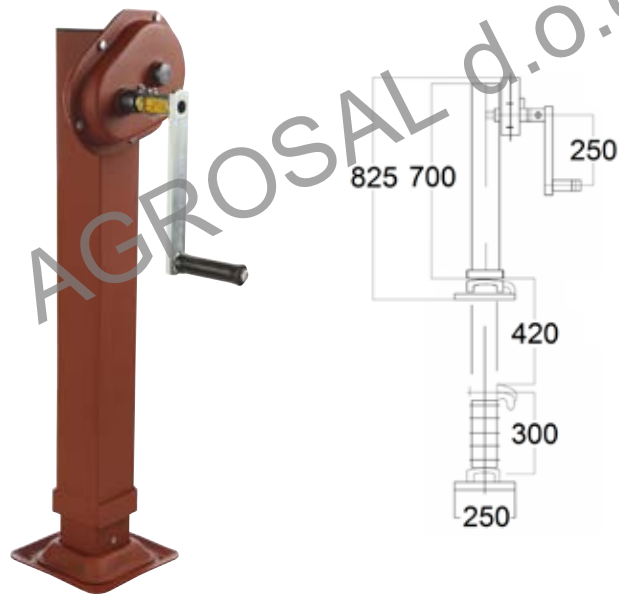
BEQUILLE A TROIS ELEMENTS POUR REMORQUES A ESSIEU CENTRAL, A DEUX VITESSES
 THREE-STAGE LANDING GEAR FOR TANDEM TRAILERS, WITH DOUBLE SPEED
 STÜTZWINDE FÜR TANDEM-ANHÄNGER, DREISTÜFIG, ZWEIGÄNGIG
 SOLLEVATORE A TRE SFILATE PER RIMORCHI TANDEM, A DUE VELOCITÀ



Art./Ref.	Sezione tubo mm/Hose section mm	Allungamento mm/Extension mm	Carico verticale/Vertical load	Peso Kg/Weight Kg
50430	110 x 110	420	10000 Kg	43,5

PIEDE D'APPOGGIO CON RIDUTTORE, DUE VELOCITÀ

PIEDS-BÉQUILLE AVEC RÉDUCTEUR, DEUX VITESSES
 PARKING JACK WITH REDUCTION GEARS, DOUBLE SPEEDS
 STÜTZFÜSSE MIT GETRIEBE, ZWEI-GÄNGIG
 PIE DE APOYO CON ENGRANAJE, VELOCIDAD DOBLE

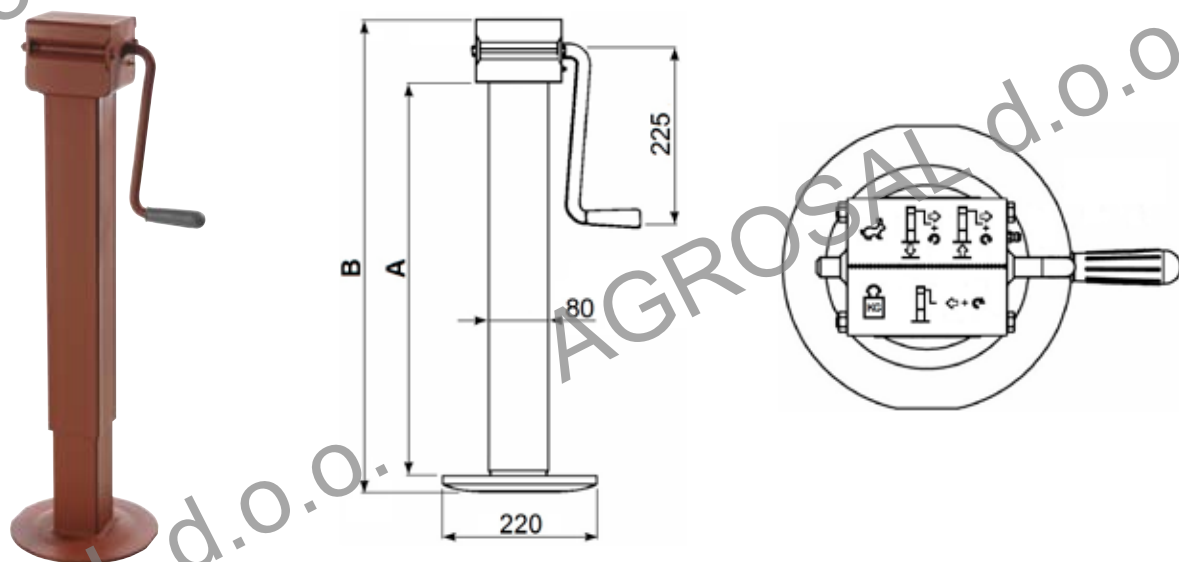

Note: Carico verticale: 4000 Kg
 MARCIA RIDOTTA: spingere la maniglia all'interno (posizione naturale) - Ideale per il sollevamento del carico.
 MARCIA VELOCE: tirare la maniglia verso l'esterno - ideale per avvicinare o allontanare l'appoggio dal terreno

Notes: Vertical load: 4000 Kg
 LOW SPEED: push the handle (start position) - ideal to lift the load
 HIGH SPEED: pull the handle - ideal to lower or to lift the jack from the ground

Art./Ref.	A mm	B mm	Peso Kg/Weight Kg
85494	600	720	18,4
85495	750	870	19,4

SERVOTIMONE CON RIBALTAMENTO SEMIAUTOMATICO E BLOCCAGGIO RUOTA A MOLLA

BEQUILLE A ROUE AVEC BLOCAGE PAR RESSORT

WHEEL JACK WITH SPRING LOCK

STÜTZRAD MIT FEDERVORRICHTUNG

PIE DE APOYO A RUEDA BLOQUEO CON RESORTE

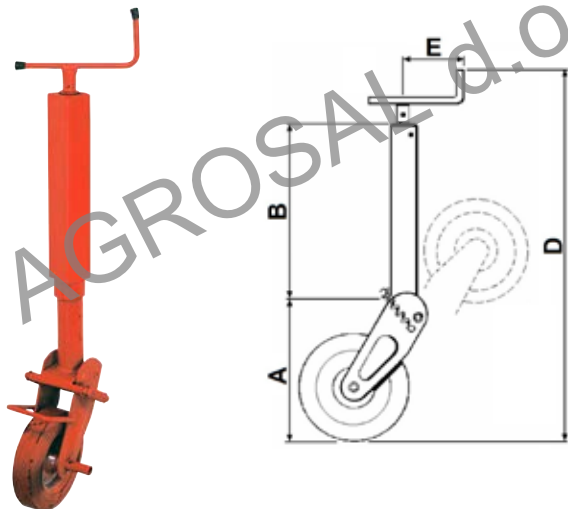

Art./Ref.	A mm	B mm	D mm	E mm	Sezione tubo mm/ Hose section mm	Allungamento mm/ Extension mm	Carico verticale/ Vertical load	Note/Note	Spessore mm/ Thickness mm	Diametro vite/ Screw diameter
00510	290	390	830	125	60 x 60	240	200 Kg	Ruota in gomma 200 x 60/Rubber wheel 200 x 60	3	22
00512	340	480	960	190	60 x 60	260	300 Kg	Ruota in gomma 250 x 80/Rubber wheel 250 x 80	3	22
00514	310	390	850	125	70 x 70	240	700 Kg	Ruota in ferro 230 x 60/Steel wheel 230 x 60	4	22
00516	380	500	960	190	70 x 70	300	800 Kg	Ruota in ferro 300 x 100/Steel wheel 300 x 100	4	22
09799	330	460	940	185	70	300	1000 Kg	Ruota in ferro 275 x 70/Steel wheel 275 x 70	4	22
00511	330	460	940	185	70	300	1000 Kg	Ruota in ferro 275 x 70/Steel wheel 275 x 70	4	29
00513	380	500	960	190	90	300	1500 Kg	Ruota in ferro 300 x 100/Steel wheel 300 x 100	4	29

SERVOTIMONE CON RIBALTAMENTO MANUALE E BLOCCAGGIO RUOTA A SPINA

BEQUILLE A ROUE AVEC BLOCAGE A VERROU

WHEEL JACK WITH PIN LOCK

STÜTZRAD MIT SPERRBOLZ

PIE DE APOYO CON RUEDA BLOQUEO CON AGUJA

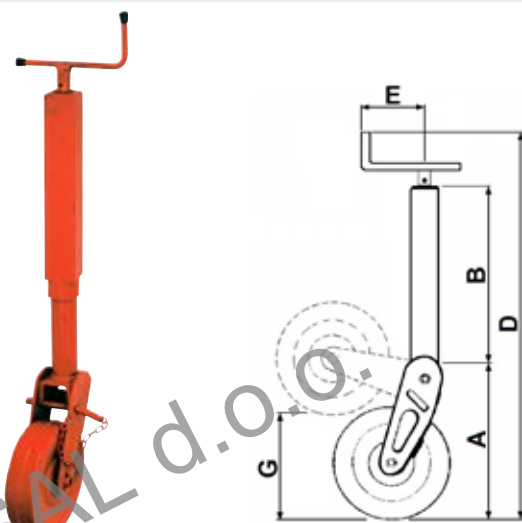

Note: Diametro vite: 22 mm

Notes: Screw diameter: 22 mm

Art./Ref.	A mm	B mm	D mm	E mm	G mm	Sezione tubo mm/ Hose section mm	Allungamento mm/ Extension mm	Carico verticale/ Vertical load	Note/Note	Spessore mm/ Thickness mm
02073	310	390	850	125	295	60 x 60	220	700 Kg	Ruota in ferro 230 x 60/Steel wheel 230 x 60	3
00520	340	480	960	190	280	70 x 70	300	800 Kg	Ruota in ferro 280 x 80/Steel wheel 280 x 80	4

SERVOTIMONE CON MANOVELLA LATERALE A RIBALTAMENTO SEMIAUTOMATICO CON BLOCCAGGIO RUOTA A MOLLA

BEQUILLE LEGERE A ROUE AVEC MANIVELLE LATERALE ET BLOCAGE À RESSORT
 WHEELED PARKING JACK WITH SIDE HANDLE AND SPRING LOCKING, LIGHT TYPE
 STUETZRAD LEICHT MIT SEITLICHER KURBEL UND BLOCKIERUNGSFEDER
 PIE DE APOYO CON RUEDA, LIGERO Y CON MANIVELA LATERAL Y SISTEMA DE BLOQUEO CON RESORTE

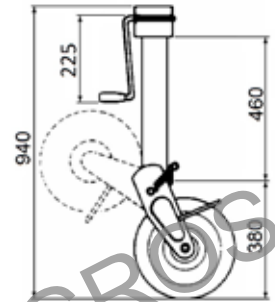

Art./Ref.	Sezione tubo mm/ Hose section mm	Allungamento mm/ Extension mm	Carico verticale/ Vertical load	Note/Note	Spessore mm/ Thickness mm	Diametro vite/ Screw diameter
17550	Ø 90 mm	300	2000	Ruota in ferro 310x90/ Steel wheel 310x90	4	28

SERVOTIMONE TIPO CRIC CON ATTACCO RIBALTABILE

BEQUILLE CRIC FIXATION BASCULANTE
 PARKING JACK TIPPING CONNECTION
 STÜTZFUSS MIT KLAPPBAREM BEFESTIGUNGSTEIL
 PIE DE APOYO TIPO CRIC - ENGANCHE BASCULANTE

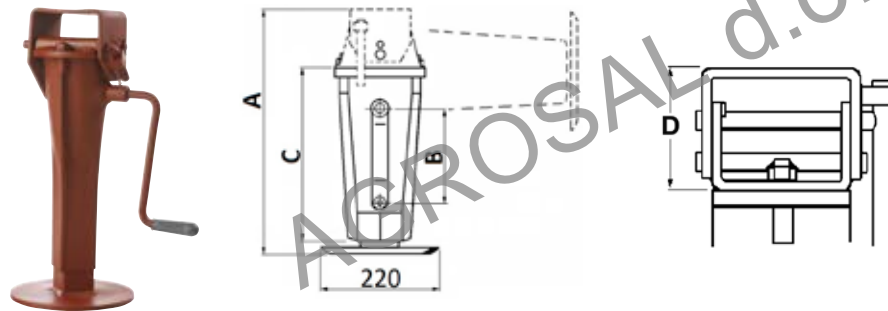

Note: Rapporto d'ingranaggio: 1 : 2,5 Sezione tubo: 70 mm
 Notes: Gear ratio: 1 : 2,5 Tube section: 70 mm

Art./Ref.	A mm	B mm	D mm	Allungamento mm/Extension mm	Carico verticale/Vertical load
01053	460	220	125	170	6000 Kg
01059	485	230	70	200	4000 Kg
02289	635	230	70	260	4000 Kg

SERVOTIMONE LEGGERO A RUOTA

BEQUILLE LEGERE A ROUE
 WHEEL JACK
 STÜTZRAD
 PIES DE APOYO CON RUEDA

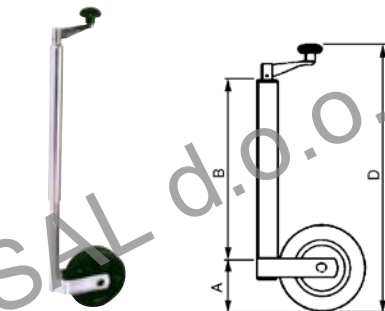

Note: Ruota in plastica
 Notes: Plastic wheel

Art./Ref.	A mm	B mm	D mm	Sezione tubo mm/Hose section mm	Allungamento mm/Extension mm	Carico verticale/Vertical load	Note/Note
12350	95	390	565	Ø 35 mm	220	75 Kg	Ruota 160 x 40/Wheel 160 x 40
12351	150	360	590	Ø 42 mm	190	150 Kg	Ruota 200 x 50/Wheel 200 x 50
12353	135	390	610	Ø 48 mm	195	150 Kg	Ruota 245 x 70/Wheel 245 x 70

SERVOTIMONE LEGGERO RUOTA

BEQUILLE LEGERE A ROUE

WHEEL JACK

STÜTZRAD

PIES DE APOYO CON RUEDA

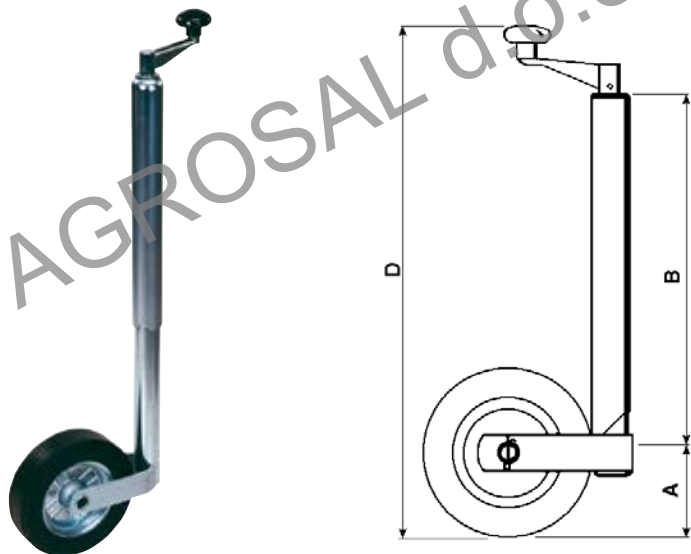
Note: Ruota gommata con disco in lamiera

Notes: Rubber wheel with sheet metal disc

Art./Ref.	A mm	B mm	D mm	Sezione tubo mm/Hose section mm	Allungamento mm/Extension mm	Carico verticale/Vertical load	Note/Note
00518	150	350	575	48	190	150	Ruota 200 x 50 /Wheel 200 x 50
12352	150	430	720	60	250	400	Ruota 255 x 80 /Wheel 255 x 80

SERVOTIMONE LEGGERO A RUOTA

BEQUILLE LEGERE A ROUE

WHEEL JACK

STÜTZRAD

PIES DE APOYO CON RUEDA

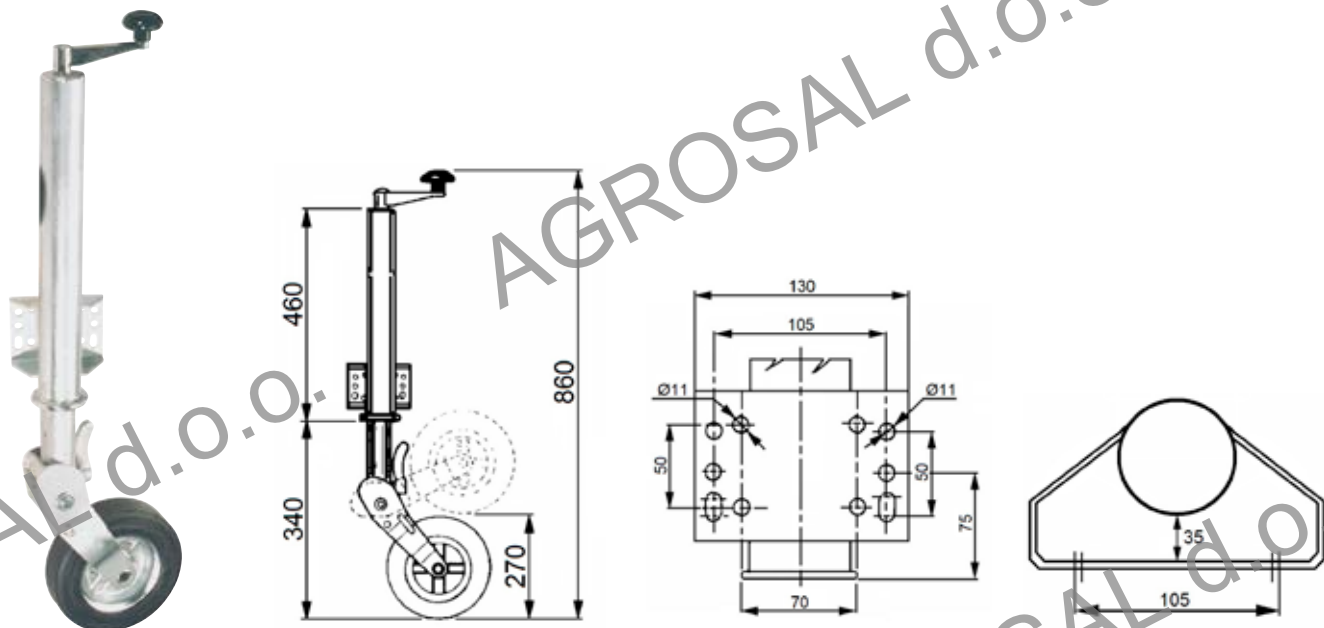
Note: Ruota gommata con disco in lamiera ribaltabile con supporto di fissaggio

Notes: Rubber wheel with tilting plate disc with fixing support

Art./Ref.	Sezione tubo mm/Hose section mm	Allungamento mm/Extension mm	Carico verticale/Vertical load	Note/Note
12354	Ø 60 mm	200	400	Ruota 200 x 60 /Wheel 200 x 60

MORSETTO DI FISSAGGIO PER SERVOTIMONE

SUPPORT COULISSANT ZINGÉE
 GALVANIZED PLATED CLAMP BRACKET
 VERZINKTE KLEMMHALTERUNG
 SOPORTE DE REGLAJE GALVANIZADO

Note: Fissaggio: da avvitare.

Notes: Fixing: bolt mount.



Art./Ref.	Brand	Applicazione/Application
12359	A.M.A.	12352, 12354

MORSETTO DI FISSAGGIO REGOLABILE ZINCATO PER SERVOTIMONE

SUPPORT COULISSANT ZINGÉE
 GALVANIZED PLATED CLAMP BRACKET
 VERZINKTE KLEMMHALTERUNG
 SOPORTE DE REGLAJE GALVANIZADO

Art./Ref.	A mm	Brand	Applicazione/Application
00527	48	A.M.A.	00518, 12353
12357	35	A.M.A.	12350
12356	42	A.M.A.	12351

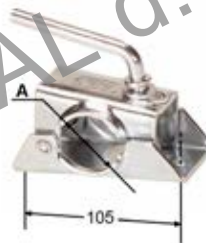

SERVOTIMONI IDRAULICI CON RITORNO A MOLLA

BEQUILLE HYDRAULIQUES
 HYDRAULIC JACKS
 HYDRAULISCHE STÜTZFÜSSE
 SERVOMANDOS DE DIRECCIÓN HIDRÁULICOS - VUELA CON RESORTE

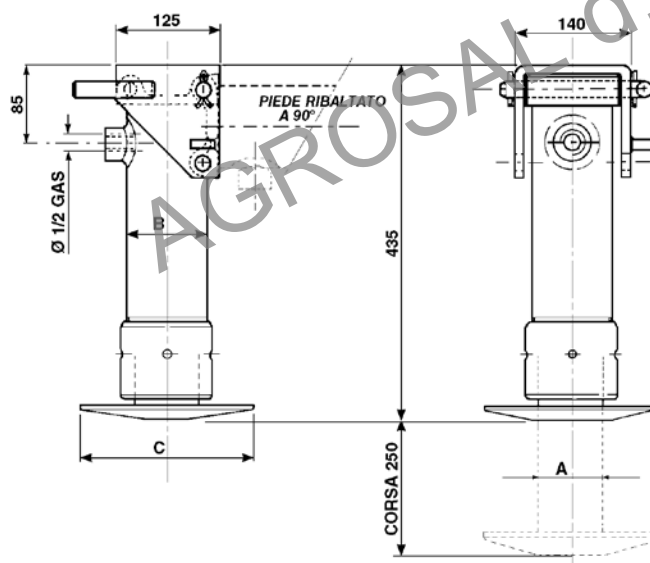

Note: Allungamento: 250 mm

Notes: Extension: 250 mm

Art./Ref.	A mm	B mm	C mm	Carico verticale/Vertical load	Note/Note
04622	65	80	160	100 bar = 3300 kg / 150 bar = 4970 kg	olio 0,8 lt
04623	85	100	215	100 bar = 5670 kg / 150 bar = 8500 kg	olio 1,5 lt

PIEDI IDRAULICI COMPLETI DI VALVOLA DI BLOCCO

BEQUILLE HYDRAULIQUES AVEC CLAPET DE BLOCAGE
 HYDRAULIC PARKING JACK WITH BUILT-IN SAFETY VALVE
 HYDRAULISCHE STÜTZFUSSE MIT SPERRBLOCKVENTIL
 PIE HIDRÁULICO DE APOYO CON VÁLVULA DE BLOQUE

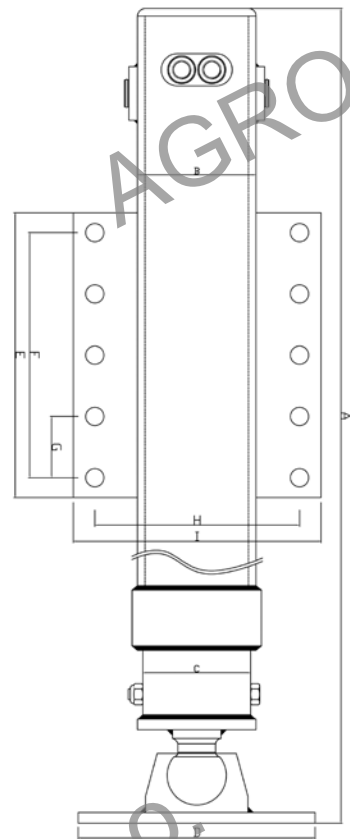
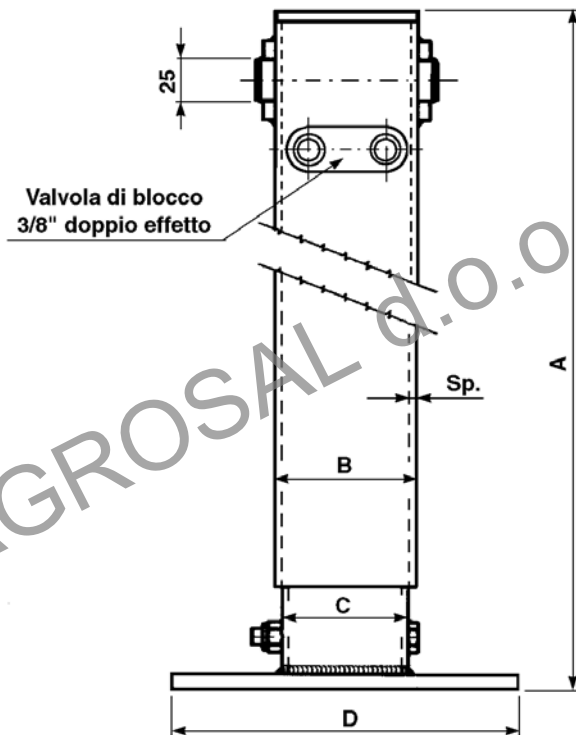

Note: Completi di valvola di blocco pilotata a doppio effetto da 3/8". Senza kit tubi. Grezzi.

Notes: Equipped with double acting check valve 3/8". Without hoses kit. Rough

Art./Ref.	A mm	B mm	C mm	D mm	E mm	F mm	G mm	H mm	I mm	Allungamento mm/ Extension mm	Carico verticale/Vertical load	Spessore mm/ Thickness mm
11016	635	90x90	80x80	220	-	-	-	-	-	350	a 100bar 1963kg, a 150bar 2945kg	4
83824	675	80X80	70X70	350	-	-	-	-	-	400	a 100bar 1256kg, a 150bar 1884kg	4
83825	762	80X80	70X70	350	-	-	-	-	-	400	a 100bar 1256kg, a 150bar 1884kg	4
10454	675	100x100	90x90	180	-	-	-	-	-	400	a 100bar 1963kg, a 150bar 2945kg	4
10455	775	100x100	90x90	180	-	-	-	-	-	500	a 100bar 1963kg, a 150bar 2945kg	4
10456	675	100x100	90x90	180	-	-	-	-	-	400	a 100bar 2824kg, a 150bar 4241kg	4
10457	775	100x100	90x90	180	-	-	-	-	-	500	a 100bar 2824kg, a 150bar 4241kg	4
11021	785	110x110	100x100	250	-	-	-	-	-	500	a 100bar 3848kg, a 150bar 5772kg	4
82796	985	110X110	100X100	250	-	-	-	-	-	700	a 100bar 3800kg, a 150bar 5700kg	4
83817	762	100X100	90X90	180	265	228	57	190	230	400	a 100bar 1900kg, a 150bar 2900kg	4
83818	862	100X100	90X90	180	265	228	57	190	230	500	a 100bar 1900kg, a 150bar 2900kg	4
83819	762	100X100	90X90	180	265	228	57	190	230	400	a 100bar 2800kg, a 150bar 4200kg	4
83821	862	100X100	90X90	180	265	228	57	190	230	500	a 100bar 2800kg, a 150bar 4200kg	4
83822	872	110X110	100X100	250	265	228	57	190	230	500	a 100bar 3800kg, a 150bar 5700kg	4
83823	1072	110X110	100X100	250	265	228	57	190	230	700	a 100bar 3800kg, a 150bar 5700kg	4

CHIUSURE A PALLA CON GOLFARO

FERMETEURE AVEC VERROU
EYEBOLT CLOSING
VERSCHLUSS MIT BALLENGRIFF
CIERRE A PELOTA CON TOPE

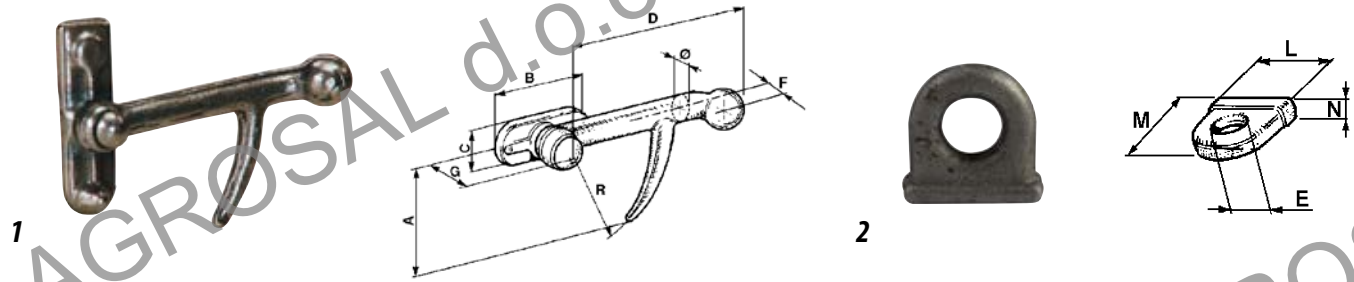

Art./Ref.	Pos.	Sezione tubo mm/Hose section mm	Tipo/Type	A mm	B mm	C mm	D mm	E mm	F mm	G mm	L mm	M mm	N mm	P mm
03518	1	12	Destra - Leggerissima/Right - Lightes	50	72	21	106	-	10	24	-	-	-	56
03519	1	12	Sinistra - Leggerissima/Left - Lightes	50	72	21	106	-	10	24	-	-	-	56
03520	2	-	-	-	-	-	-	9,5	-	-	27	26	11	-
03521	1	13	Destra - Leggera/ Right - Lightes	65	50	26	130	-	12	28	-	-	-	81
03522	1	13	Sinistra - Leggera/ Left - Lightes	65	50	26	130	-	12	28	-	-	-	81
03523	2	-	-	-	-	-	-	12	-	-	31	30	12	-
03524	1	16	Destra - Media/ Right - Medium	70	55	30	155	-	13	33	-	-	-	93
03525	1	16	Sinistra - Media/ Left - Medium	70	55	30	155	-	13	33	-	-	-	93
03526	2	-	-	-	-	-	-	14,5	-	-	35	33	12	-
03527	1	15x20	Destra - Pesante lunga/ Right - Heavy long	80	75	35	180	-	12	40	-	-	-	107
03528	1	15x20	Sinistra - Pesante lunga/ Left - Heavy long	80	75	35	180	-	12	40	-	-	-	107
03529	2	-	-	-	-	-	-	17,5	-	-	42	42	15	-

CHIUSURA AD ANELLO QUADRO

FERMETEURE AVEC PLAQUETTE
SQUARE EYE CLOSING WITH PLATE
VERSCHLUSS MIT PLÄTTCHEN
CIERRE A ANILLO CUADRO CON PLATO

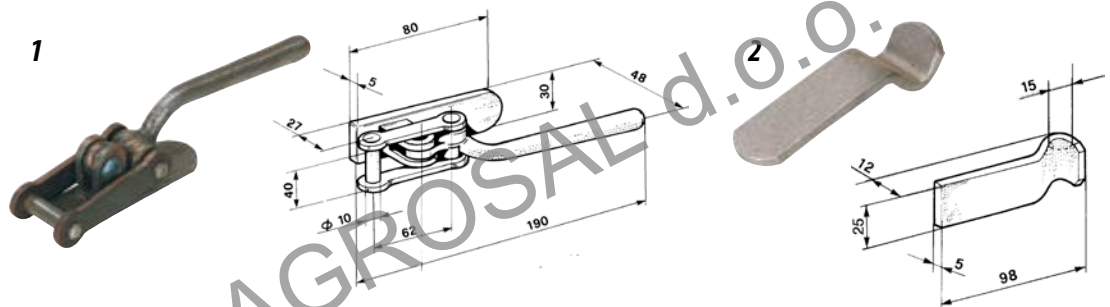

Art./Ref.	Pos.
00590	1
11761	2

CHIUSURA REGISTRABILE AD OCCHIO

FERMETEURE REGLABLE
ADJUSTABLE CLOSING
VERSTELLBARER VERSCHLUSS
CIERRE AJUSTABLE A OJO CON GANCHO

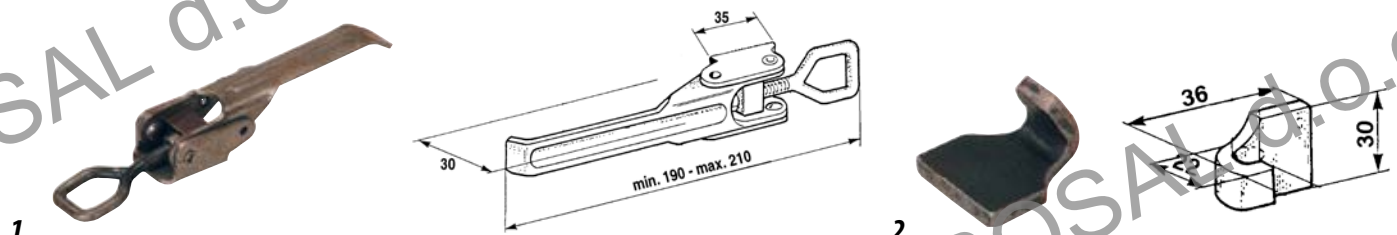

Art./Ref.	Pos.
02741	1
11762	2

CHIUSURA REGISTRABILE ADATTABILI A SCOTT

FERMETURE REGLABLE ADAPTABLE SCOTT
 ADJUSTABLE CLOSING ADAPTABLE TO SCOTT
 VERSTELLBARER VERSCHLUSS PASSEND ZU SCOTT
 CIERRE AJUSTABLE ADAPTABLE A SCOTT

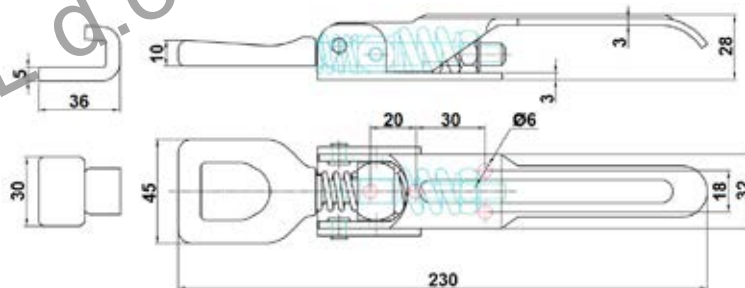
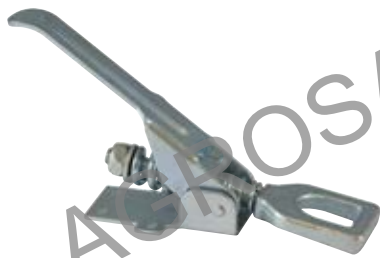

Note: Zincata. Peso: 52 gr

Notes: Galvanized. Weight: 52 gr

Art./Ref.
88922

CHIUSURA REGISTRABILE A "T"

FERMETURE REGLABLE LEGERE
 LIGHT ADJUSTABLE CLOSURE
 VERSCHLUSS VERSTELLBAR
 CIERRE AJUSTABLE A "T"

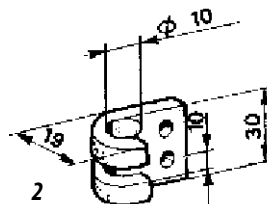
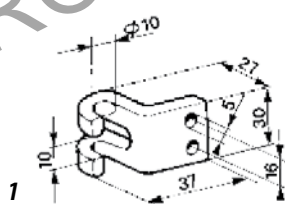

Art./Ref.	Pos.	Note/Note
11763	1	Zincata/ Galvanized
11764	2	Grezzo/ Rough
11765	2	Zincata/ Galvanized
04619	3	Grezzo/ Rough
11811	3	Zincata/ Galvanized

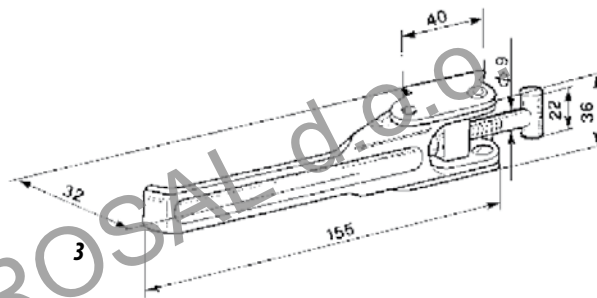
CHIUSURA REGISTRABILE TIPO FRANCIA

FERMETURE REGLABLE TYPE FRANCE AVEC GACHE
 HEAVY ADJUSTABLE CLOSURE
 VERSTELLBARER VERSCHLUSS SCHWER
 CIERRE AJUSTABLE TIPO "FRANCIA"

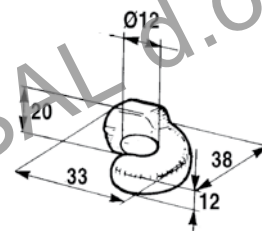
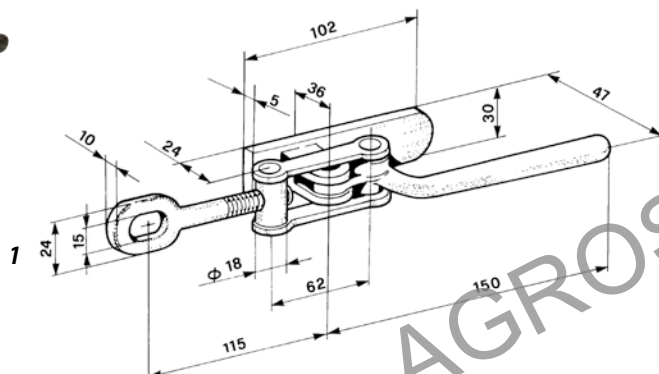

Art./Ref.	Pos.
00641	1
11766	2

CHIUSURA REGISTRABILE TIPO EXTRA

FERMETEURE REGLABLE "EXTRA"
 ADJUSTABLE CLOSURE
 VERSTELLBARER VERSCHLUSS EXTRA TYP
 CIERRE AJUSTABLE TIPO "EXTRA"

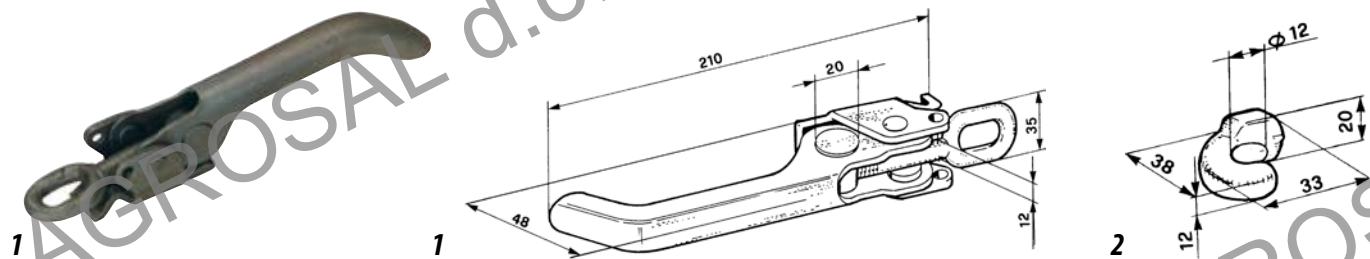

Art./Ref.	Pos.
04620	1
11766	2

PERNO A MOLLA

AXE A RESSORT
 SPRING PIN
 BOLZEN MIT FEDER
 PERNO DE MUELLE

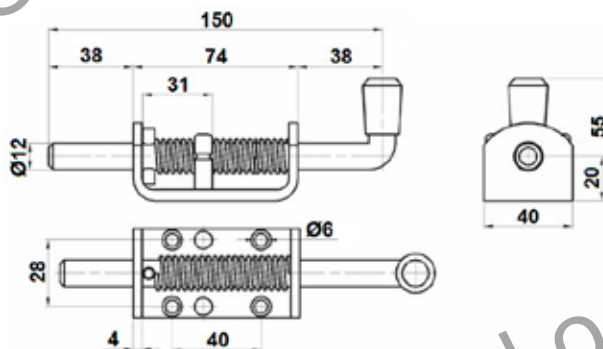

Note: Peso: 355 gr
 Notes: Weight: 355 gr

Art./Ref.	Tipo/Type
88923	Zincato/ Galvanized
88924	Acciaio inox/ Stainless steel

CHIUSURA FERMA UTENSILE DA Ø 28 A Ø 40 MM

FERMETURE DE Ø 28 A Ø 40 MM
 CLOSING Ø 28 TO Ø 40 MM
 VERSCHLUSS VON Ø 28 BIS Ø 40 MM
 CIERRE DE Ø 28 A Ø 40 MM

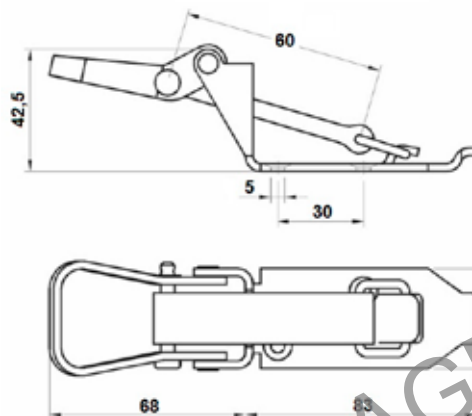

Note: Zincata. Peso: 145 gr
 Notes: Galvanized. Weight: 145 gr

Art./Ref.
88928

CHIUSURA PER RIMORCHIO

FERMETURE DE REMORQUE

CLOSING FOR TRAILER

SCHLIESSEN FÜR KIPPANHÄNGER

CIERRE PARA REMOLQUE



Art./Ref.
59160

CHIUSURA CON MOLLA

FERMETURE A RESSORT

SPRING CLOSING

EXZENTERVERSCHLUSS MIT FEDER

CIERRE DE MUELLE



Art./Ref.
59161

FASCIA BLOCCAGGIO CHIUSURA

BANDE BLOCAGE DE FERMETURE

BAND LOCK CLOSURE

BAND FÜR VERSCHLUSS

BANDA DE BLOQUEO CIERRE

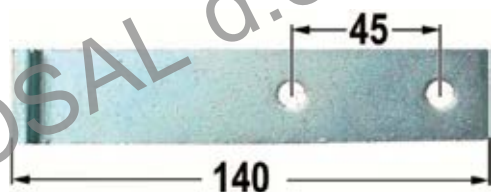

Art./Ref.	Brand	Applicazione/Application
59174	A.M.A.	59160, 59161

CHIUSURA UNIVERSALE M50

FERMETURE UNIVERSAL M50
 UNIVERSAL TRAILER CLOSURE M50
 UNIVERSALVERSCHLUSS M50
 CIERRE UNIVERSAL M50

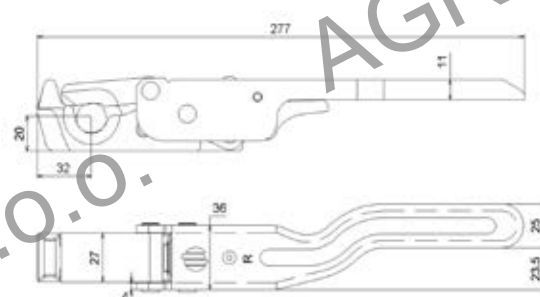
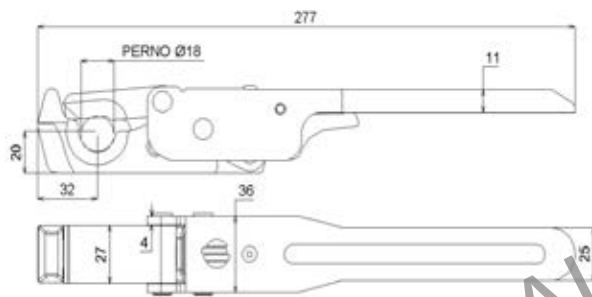

Note: Versione in acciaio forgiato e lamiera P12 tranciata.
 Impiegata in allestimenti fissi e ribaltabili con sponde in ferro. Agevola la chiusura della sponda trascinando nella sua sede il perno vincolato alla sponda.
 E' dotata di un dispositivo che ne evita l'apertura accidentale.

Notes: Version in casting and metal sheet P12.
 Application on steel panels tippers or platforms.
 Equipped with a safety trigger avoiding incidental openings.

Art./Ref.	Pos.	Tipo/Type
59169	1	Dritto/Straight
59172	2	Destra/Right
59173	3	Sinistra/Left

PERNO PER CHIUSURA M50

AXE POUR FERMETURE M50
 PIN FOR M50 CLOSURE
 BOLZEN FÜR VERSCHLUSS M50
 PERNO PARA CIERRE M50

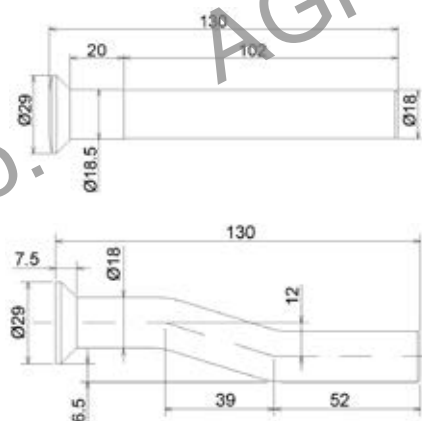

Note: Per art. 59169 - 59172 - 59173

Notes: For item 59169 - 59172 - 59173

Art./Ref.	Pos.	Tipo/Type
59170	1	Dritto/Straight
59171	2	Curvo/Curved

CHIUSURA UNIVERSALE TRILATERALE

FERMETURE UNIVERSELLE
TIPPING TRAILER CLOSURE
UNIVERSALVERSCHLUSS
CIERRE UNIVERSAL TRILÁTERO

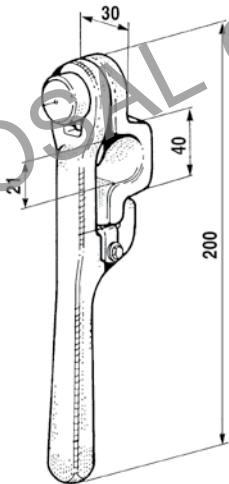

Art./Ref.
00658

PIANTONE PER CHIUSURA ART. 00658

AXE POUR FERMETURE ART. 00658
PIN FOR CLOSURE ART. 00658
BOLZEN FÜR VERSCHLUSS ART. 00658
PERNO PARA CIERRE ART. 00658

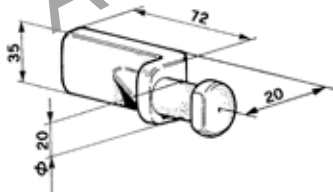

Art./Ref.
00659

CHIUSURA MAROTTA BREVETTATA

FERMETURE MAROTTA
MAROTTA FITTING PATENTED
VERSCHLUSS "MAROTTA" PATENTIERT
CIERRE MAROTTA PATENTADO

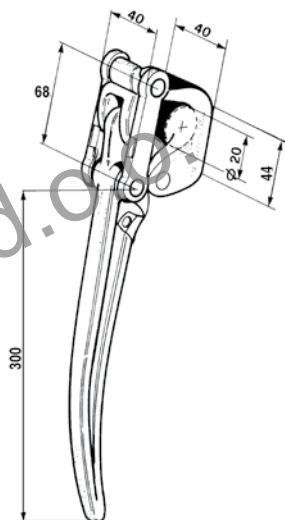

Art./Ref.
03990

PIANTONE Ø 20 PER CHIUSURA ART. 03990

AXE Ø 20 POUR FERMETURE ART. 03990
PIN Ø 20 FOR SMALL ART. 03990
BOLZEN FÜR VERSCHLUSS ART. 03990
PERNO Ø 20 PARA CIERRE ART. 03990

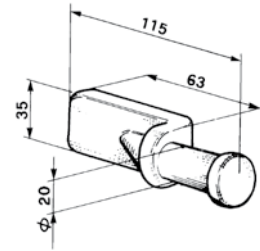

Art./Ref.
04871

CERNIERE POSTERIORI

CHARNIERE ARRIERE
REAR HINGE
HECKSCHARNIER
CHARNIERA POSTERIOR

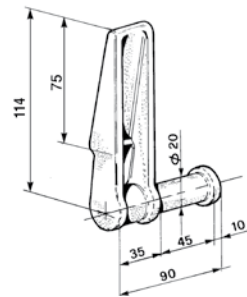

Art./Ref.	Tipo/Type
04047	Sinistra/Left
00599	Destra/Right

CHIUSURA UNIVERSALE

FERMETURE UNIVERSELLE A SOUDER AVEC CRAN
UNIVERSAL CLOSURE WITH SAFETY HOOK
UNIVERSALVERSCHLUSS ZUM ANSCHWEISSEN
CIERRE UNIVERSAL SOLDADO CON SEGURO

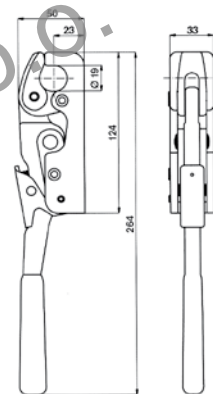

Art./Ref.
37040

PIANTONE Ø 20 PER CHIUSURA UNIVERSALE ART. 37040

AXE Ø 20 POUR FERMETURE UNIVERSELLE
PIN Ø 20 FOR SMALL CLOSURE
BOLZEN Ø 20 FÜR UNIVERSALVERSCHLUSS
PERNO Ø 20 PARA CIERRE UNIVERSAL



Art./Ref.
37041

PERNO RIBATTUTO

AXE RÉPOND
RIVETTED PIN
BOLZEN ENTGEGNETE
PERNO RESPONDIÓ

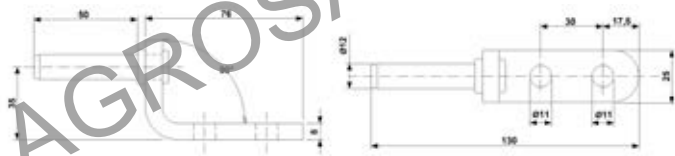

Note: Zincato.
Notes: Galvanized.

Art./Ref.
59166

PIANTONI

AXES
PINS
BOLZEN
PERNOS

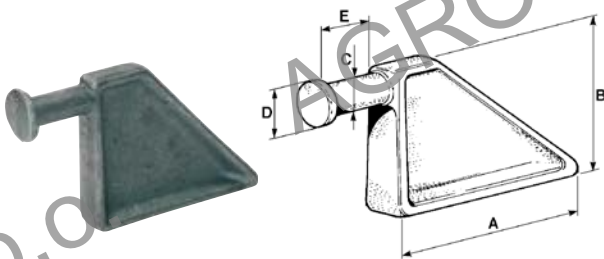

Art./Ref.	A mm	B mm	C mm	D mm	E mm
00601	128	108	20	32	45
08004	130	110	24	34	48
01577	130	120	30	41	45
02018	135	130	40	52	55

CHIUSURE A BLOCCO

FERMETURE A BLOC
LINK BLOCK LOCKS
SPERRVERSCHLUSS
CIERRE CON BLOQUE

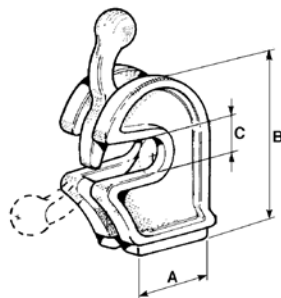

Art./Ref.	A mm	B mm	C mm
00602	62	115	20
08003	62	114	24
01576	78	122	30
02017	98	140	40

PIANTONE LEGGERO

AXE
LIGHT SHOOT TYPE
LEICHTER BOLZ
PERNO LIGERO

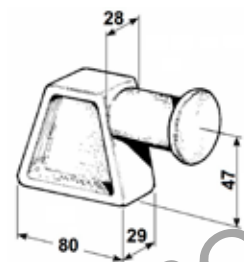

Art./Ref.
02007

CHIUSURA A BLOCCO LEGGERA

FERMETURE A BLOC LEGERE
LIGHT LINK-BLOC TYPE
LEICHTER SPERRVERSCHLUSS
CIERRES LIGEROS CON BLOQUE

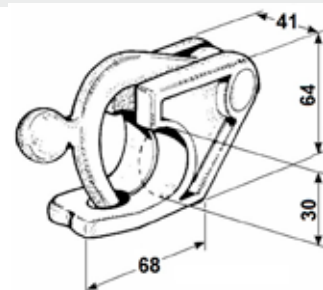

Art./Ref.
02008

CHIUSURA A CADUTA

FERMETURE A CHUTE
DROP CLOSURE
FALL-VERSCHLUSS
CIERRE A CAÍDA

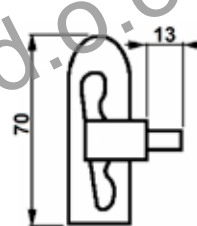

Art./Ref.
12434

CHIUSURA A CADUTA CON VITE CORTA

FERMETURE A CHUTE
DROP CLOSURE WITH SHORT SCREW
FALL-VERSCHLUSS MIT KURZER SCHRAUBE
CIERRE A CAÍDA CON TORNILLO CORTO

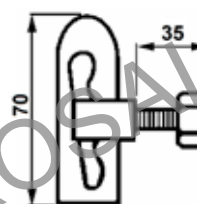

Art./Ref.
12433

CHIUSURA A MOLLA

FERMETURE A RESSORT
SPRING CLOSING
VERSCHLUSS
CIERRE DE MUELLE

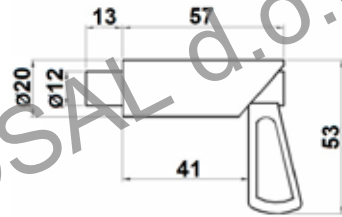

Note: Zincata. Peso: 15 gr
Notes: Galvanized. Weight: 15 gr

Art./Ref.
88917

CHIUSURA A MOLLA CON PIASTRA VERTICALE

FERMETURE A RESSORT AVEC PLAQUE VERTICALE
SPRING CLOSING WITH VERTICAL PLATE
VERSCHLUSS MIT SENKRECHTER PLATTE
CIERRE DE MUELLE CON LASTRA VERTICAL

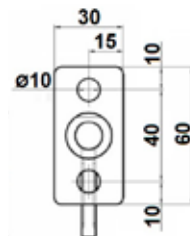
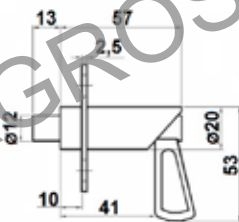

Note: Zincata. Peso: 18 gr
Notes: Galvanized. Weight: 18 gr

Art./Ref.
88918

CHIUSURA CON MOLLA CON PIASTRA ORIZZONTALE

FERMETURE A RESSORT AVEC PLAQUE HORIZONTALE
SPRING CLOSING WITH HORIZONTAL PLATE
VERSCHLUSS MIT WAAGERECHTER PLATTE
CIERRE DE MUELLE CON LASTRA HORIZONTAL

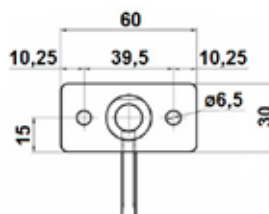
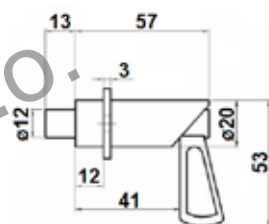

Note: Zincata. Peso: 18 gr
Notes: Galvanized. Weight: 18 gr

Art./Ref.
88919

MANIGLIA FISSA

POIGNEE FIXATION
TIE HANDLE
SPERRSTIFT
MANILLA DE FIJACIÓN

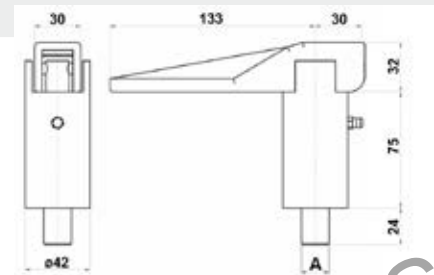

Note: Zincata.
Notes: Galvanized.

Art./Ref.	A mm	Peso Kg/Weight Kg
88929	18	1,25
88930	25	1,3

CERNIERE PIATTE E BOMBATE E PERNI PER CERNIERE

CHARNIERES PLATES ET BOMBES ET AXES
HINGES AND PIN
SCHARNIERE UND BOLZEN
CIERRES PLANAS Y PERNOS PARA CIERRES

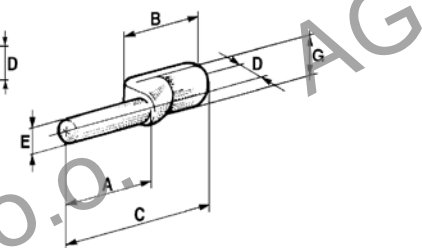
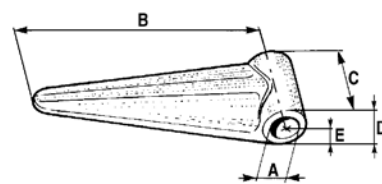

3

Art./Ref.	Pos.	Tipo/Type	A mm	B mm	C mm	D mm	E mm	G mm	Brand	Applicazione/Application
01568	1	Piatta micro/ Micro flat	9	68	24	18	9	-	-	-
01569	3	-	30	30	60	9	8	19	A.M.A.	01568
00624	1	Piatta mignon/ Mignon flat	12	54	30	19	10	-	-	-
00591	1	Piatta leggerissima/ Lightes flat	12	85	30	18	9	-	-	-
00595	2	Bombata leggera/ Light swelled	12	92	30	22	11	-	-	-
00603	3	-	40	40	80	12	11	27	A.M.A.	00591, 00595, 00624
00594	1	Piatta leggera/ Light flat	14	92	30	22	11	-	-	-
00596	2	Bombata media/ Medium swelled	14	110	35	24	12	-	-	-
00604	3	-	50	50	100	17	13	30	A.M.A.	00594, 00596
00597	2	Bombata pesante/ Heavy swelled	16	122	44	27	14	-	-	-
06116	1	Viberti corta/ Viberti short	16	137	33	27	14	-	-	-
00605	3	-	50	55	105	16	15	30	A.M.A.	00597, 06116

CERNIERA PIATTA PER SPONDE CON BORDINO

CHARNIERE PLATE
HINGE
SCHARNIER
CIERRE PARA REJA CON BORDE

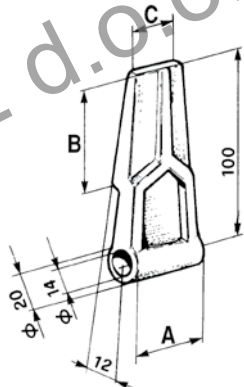

Art./Ref.	A mm	B mm	C mm
02758	38	60	25
02760	46	63	30

PERNO PER CERNIERA ART. 02758 - 02760

AXE POUR CHARNIERE REF. 02758-02760
HINGE PIN FOR ART. 02758-02760
BOLZEN FÜR SCHARNIER ART.02758-02760
PERNO PARA CIERRE 02758-02760

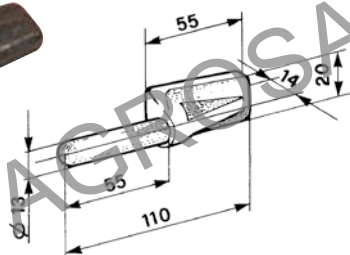

Art./Ref.
02761

CERNIERA POSTERIORE Ø 20 MM

CHARNIERE ARRIERE Ø 20 MM
REAR HINGE Ø 20 MM
HECKSCHARNIER Ø 20 MM
CHARNELA POSTERIOR Ø 20 MM

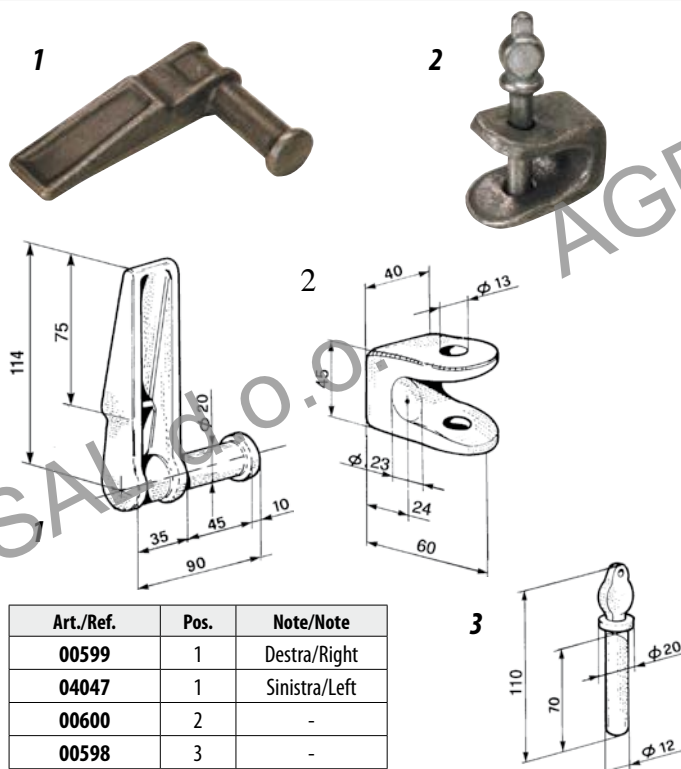

Art./Ref.	Pos.	Note/Note
00599	1	Destra/Right
04047	1	Sinistra/Left
00600	2	-
00598	3	-

CERNIERA POSTERIORI Ø 16 MM

CHARNIERE ARRIERE Ø 16 MM
REAR HINGE Ø 16 MM
HECKSCHARNIER Ø 16 MM
CIERRE POSTERIOR Ø 16 MM

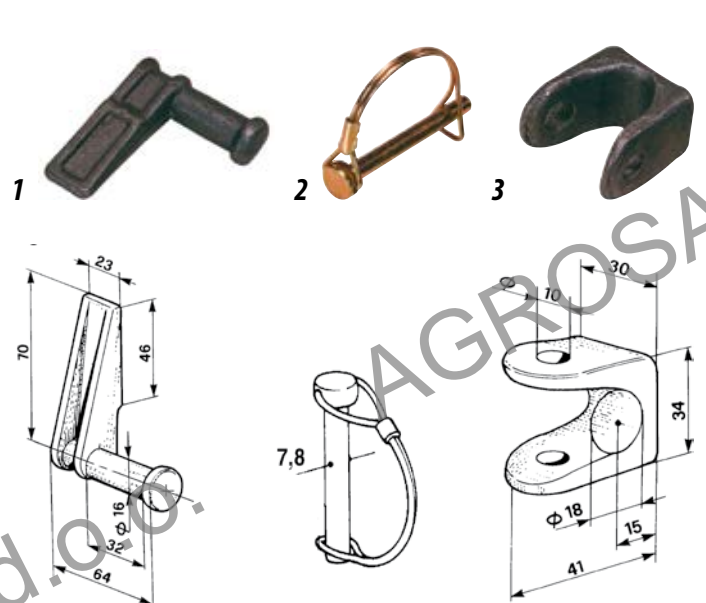

Art./Ref.	Pos.	Tipo/Type
03085	1	Sinistra/Left
04621	1	Destra/Right
01369	2	-
03086	3	-

FORCELLA RIBALTABILE

CHAPE BASCULANTE
FORK FOR TIPPING TRAILERS
KIPLAGER
HORQUILLA BASCULANTE

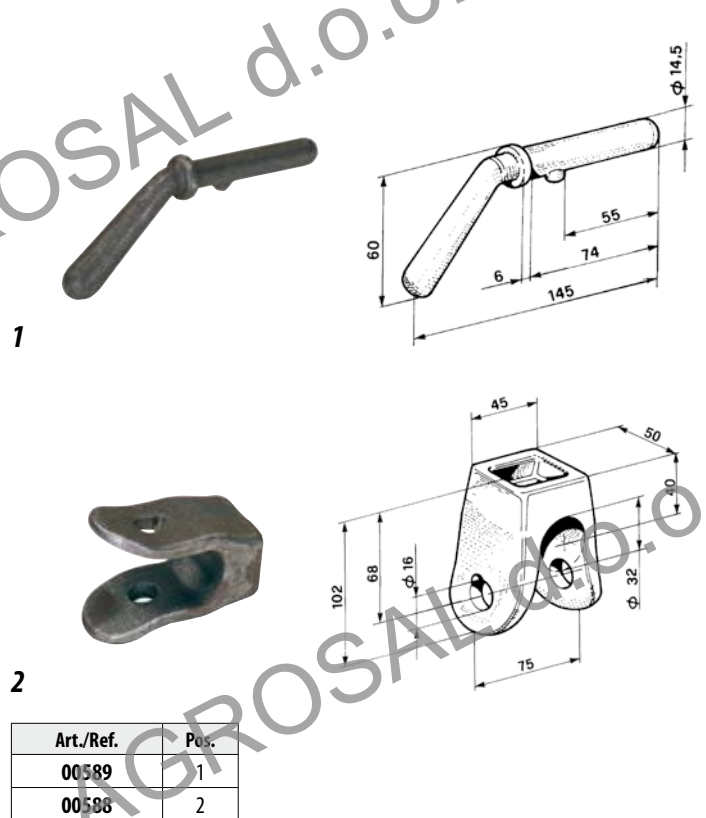

Art./Ref.	Pos.
00589	1
00586	2

CERNIERA CON STAFFA CORTA

CHARNIERE AVEC SUPPORT COURT
HINGE WITH SHORT STIRRUP
SCHARNIER MIT KURZEM BÜGEL
CIERRE CON BRIDA CORTA

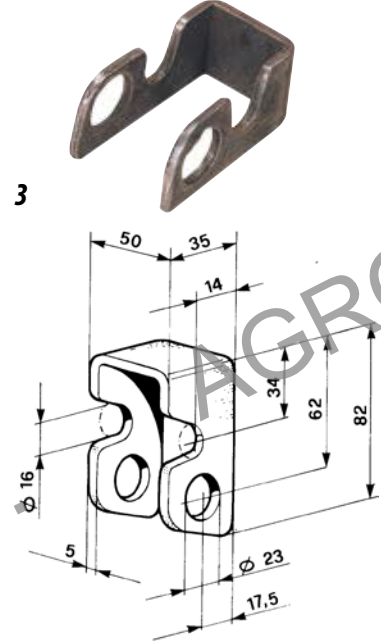
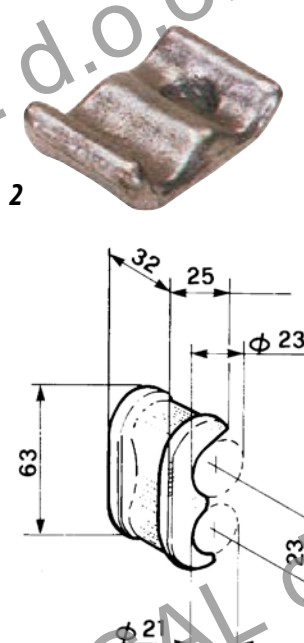
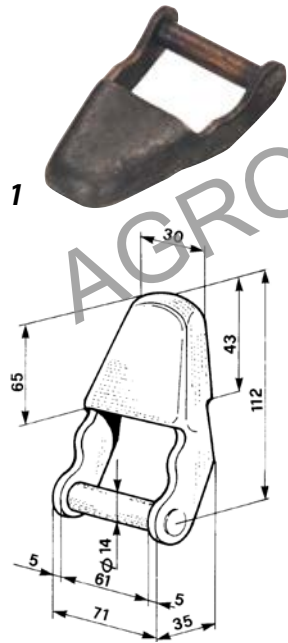

Art./Ref.	Pos.
03280	1
03282	2
03288	3

CERNIERA CON STAFFA CORTA

CHARNIERE AVEC SUPPORT COURT
HINGE WITH SHORT STIRRUP
SCHARNIER MIT KURZEM BÜGEL
CIERRE CON BRIDA CORTA

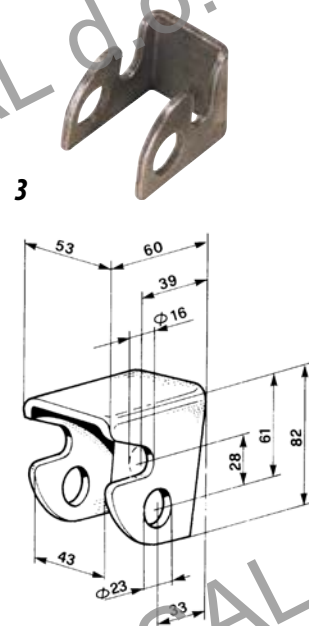
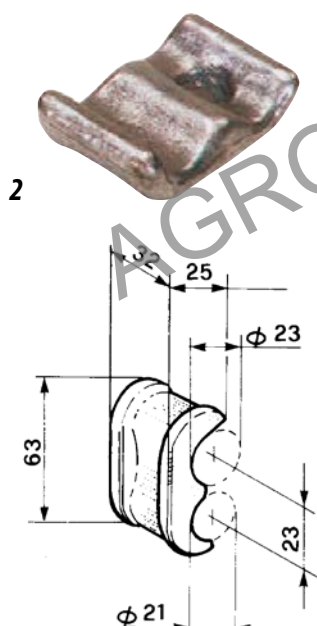
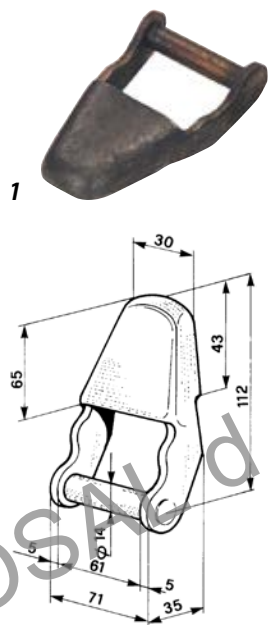

Art./Ref.	Pos.
03280	1
03282	2
03289	3

CERNIERA CON STAFFA LUNGA

CHARNIERE AVEC SUPPORT LONG
HINGE WITH LONG STIRRUP
SCHARNIER MIT LANGEM BÜGEL
CIERRE CON BRIDA LARGA

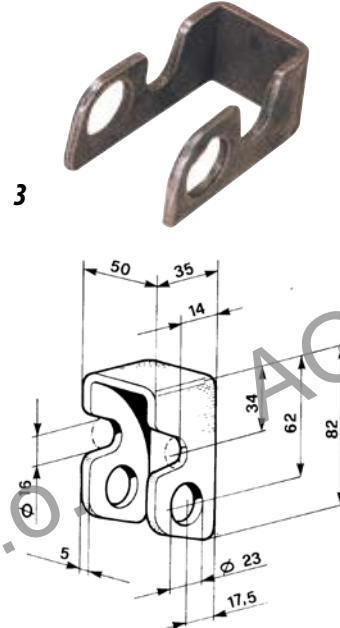
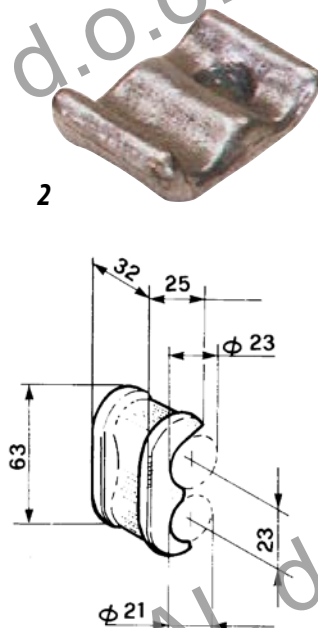
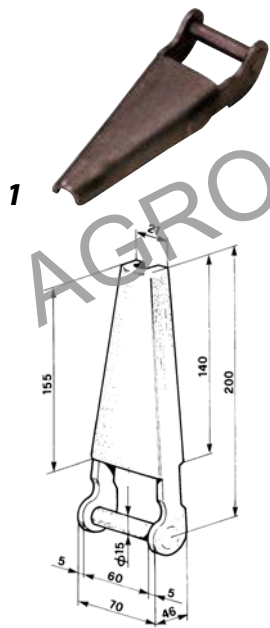

Art./Ref.	Pos.
03281	1
03282	2
03288	3

CERNIERA CON STAFFA LUNGA

CHARNIERE AVEC SUPPORT LONG
HINGE WITH LONG STIRRUP
SCHARNIER MIT LANGEM BÜGEL
CIERRE CON BRIDA LARGA

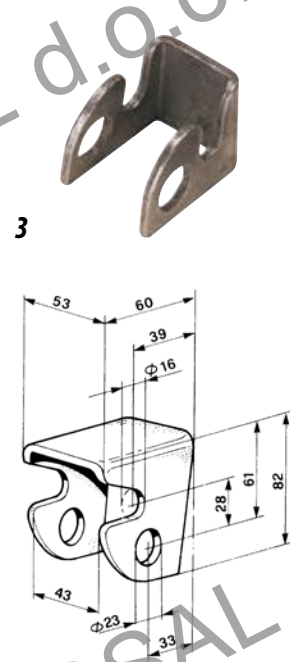
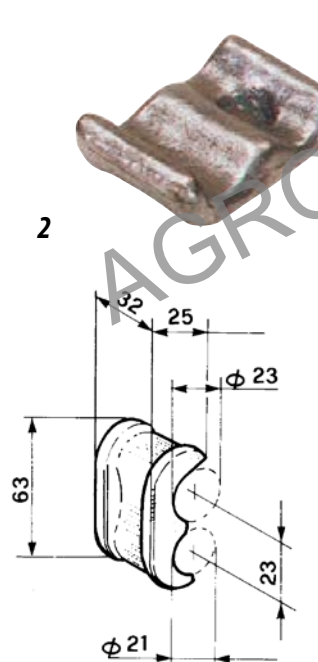
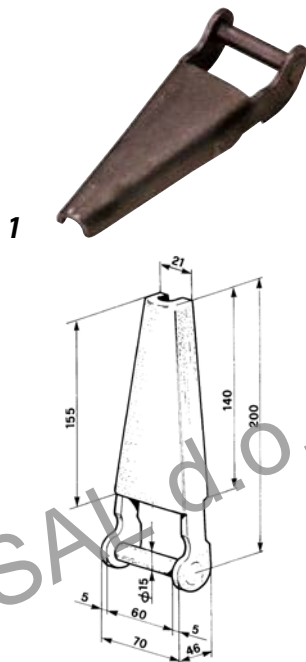

Art./Ref.	Pos.
03281	1
03282	2
03289	3

CERNIERA BILATERALE TIPO ROMA

CHARNIÈRE BILATERALE TYPE "ROME"
HINGE BILATERAL TYPE "ROME"
SEITLICHES SCHARNIER TYP "ROMA"
CIERRE BILATERAL TIPO "ROMA"

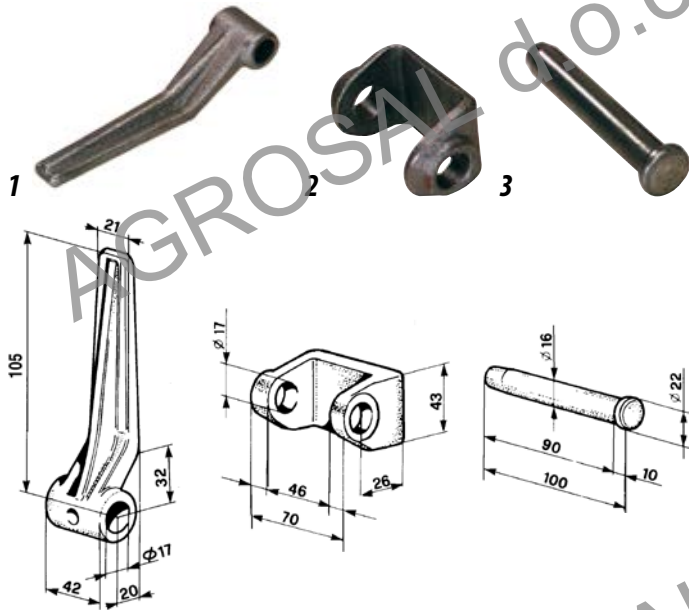

Art./Ref.	Pos.
01190	1
01189	2
01195	3

CAVALLOTTO STOPPED

BLOPAGE TYPE STOPPED
LOCKING DEVICE STOPPED
KIPPLAGER STOPPED
HORQUILLA DE BLOQUE STOPPED

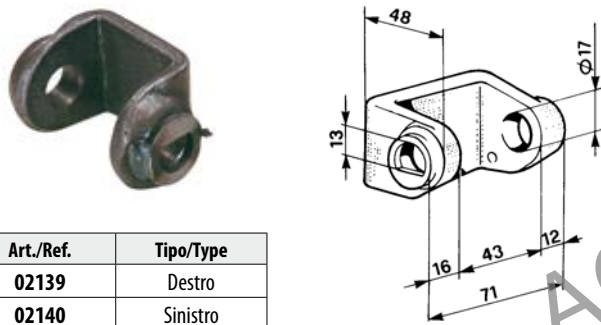

Art./Ref.	Tipo/Type
02139	Destro
02140	Sinistro

MANIGLIA PER CAVALLOTTO STOPPED

VERROU BLOPAGE
HANDLE FOR STOPPED TOOL COUPLING FORK
SPERRSTIFT ZU KIPPLAGER STOPPED
MANGO PARA HORQUILLA DE BLOQUE STOPPER

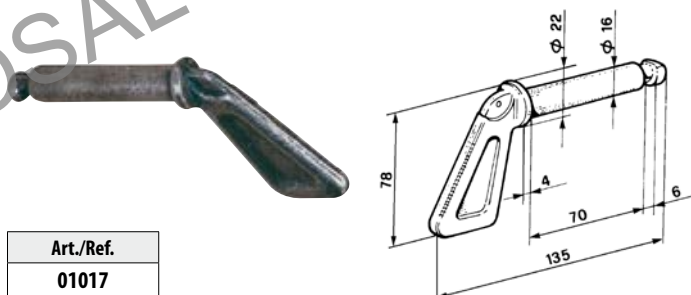

Art./Ref.
01017

CERNIERE A 5 PIVOTI IN ACCIAIO

CHARNIÈRE
HINGE
SCHARNIER
CIERRE CON 5 PIVOTES DE ACERO



Art./Ref.	A mm	L mm	Spessore mm/Thickness mm
01826	60	80	7
01847	40	50	5

CERNIERE SAGOMATE IN LAMIERA PER SOVRASPONDA

CHARNIÈRES EN TOLE POUR RIDELLES
SHAPED-PLATE HINGES
BORDWANDSCHARNIER AUS BLECH
CIERRE MOLDURADAS DE PLANCHA PARA ADRAL

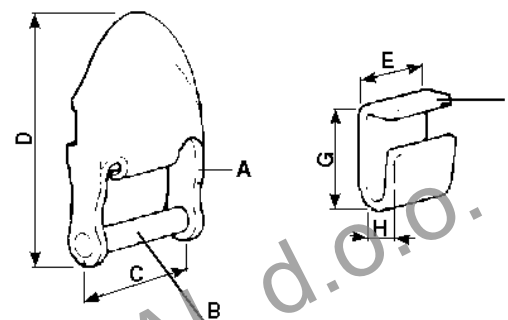

Art./Ref.	A mm	B mm	C mm	D mm	E mm	F mm	G mm	H mm
01895	3	10	42	78	30	5	40	23
01896	5	12	56	113	36	5	53	26

SUPPORTO PIANTONE LUNGO MASCHIO

SUPPORT AXE LONG MALE
SUPPORT MALE FOR HINGES
RUNGENKEIL
SOPORTE EJE LARGO MACHO



Art./Ref.
03376

SUPPORTO PIANTONE NORMALE FEMMINA

SUPPORT AXE FEMELLE
SUPPORT FEMALE FOR HINGES
WEIBLICHE RUNGEHALTERUNG
SOPORTE EJE NORMAL HEMBRA

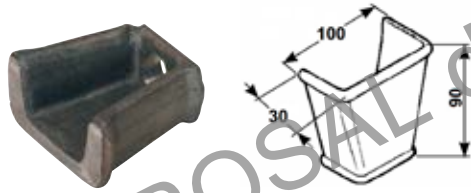

Art./Ref.
03375

DOPIO ANELLO DI FERMO PER CERNIERE SOTTOSOPRA

DOUBLE ANNEAU DE FERMETURE POUR CHARNIÈRE DOUBLE
DOUBLE LINK OF LOCK FOR DOUBLE HINGES
DOPPELRING FÜR DOPPELVERSCHLUSS
DOBLE ANILLO DE BLOQUE PARA CIERRES

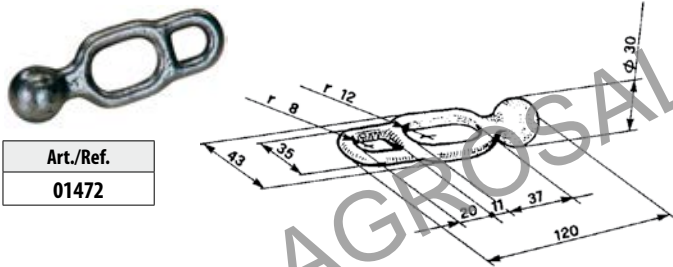

Art./Ref.
01472

SPONDE PROFILATE IN LAMIERA NERA

RIDELLES
CLACK SHEET EDGES
BORDWANDE
BORDES PERFIL DE CHAPA NEGRA

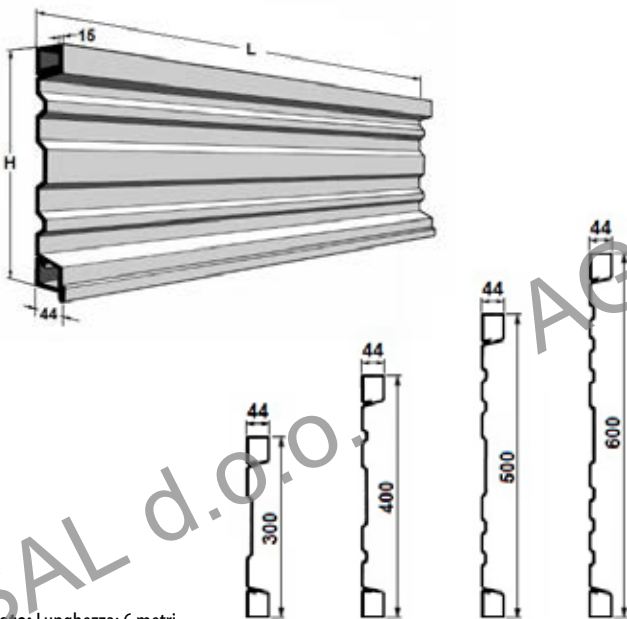

Note: Lunghezza: 6 metri
Notes: Length: 6 meters

Art./Ref.	H mm	Peso Kg/Weight Kg	Tipo/Type
85524	300	39	Senza bordino/ Without edge
85525	400	49	Con bordino/ With edge
85526	500	56	Con bordino/ With edge
85527	600	63	Con bordino/ With edge

MONTANTI

MONTANTS
FRONT
RUNGEN
MONTANTES



Art./Ref.	Peso Kg/Weight Kg	Brand	Applicazione/Application
85534	0,32	A.M.A.	85524
85535	0,48	A.M.A.	85525
85936	0,63	A.M.A.	85526
85537	0,79	A.M.A.	85527

TESTATE

TETES
TRUCK EDGES PARTS
KOPFSTÜCKE
CABEZAS



Art./Ref.	Peso Kg/Weight Kg	Brand	Applicazione/Application
85528	0,48	A.M.A.	85524
85529	0,67	A.M.A.	85525
85932	0,87	A.M.A.	85526
85533	1,06	A.M.A.	85527

PEDANA SALITA PIEGHEVOLE

MARCHEPIED ESCAMOTABLE
FOLDING STEP
KLAPPTRITT
ESCALERA PLEGABLE

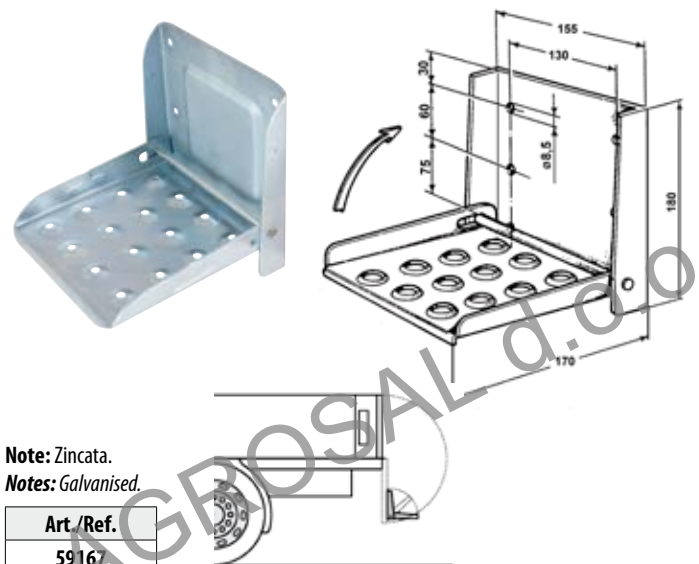

Note: Zincata.
Notes: Galvanised.

Art./Ref.
59167

BOCCHETTA PER GRANO CON FLANGIA

GOULOTTE POUR GRAINS AVEC BRIDE
DRAIN-PIPE FOR CORN WITH FLANGE
FLANSCHSTÜTZE FÜR GETREIDEWAGEN
BOCA DE DESCARGA PARA GRANO CON COLLAR

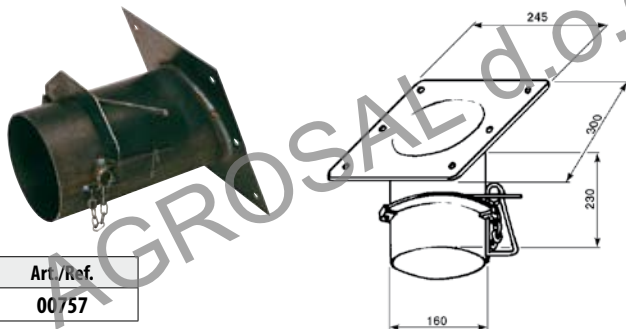

Art./Ref.	00757
-----------	-------

VERRICELLI PER RIMORCHI

TREUILS
WINCHES
SEILWINDEN
TORNOS

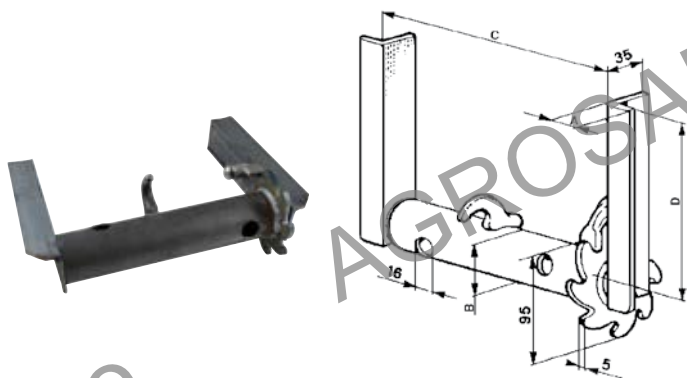

Art./Ref.	Tipo/Type	A mm	B mm	C mm	D mm
03530	Destro/Right	20	42	200	170
03531	Sinistro/Left	20	42	200	170
03532	Destro/Right	30	48	230	190
03533	Sinistro/Left	30	48	230	190
03534	Destro/Right	30	60	300	250
03535	Sinistro/Left	30	60	300	250

VERRICELLO INDUSTRIALE

TREUILS INDUSTRIELS
WINCH INDUSTRIAL TYPE
SEILWINDE INDUSTRIE - TYP
TORNOS INDUSTRIALES

Modello Dx
Rx Model

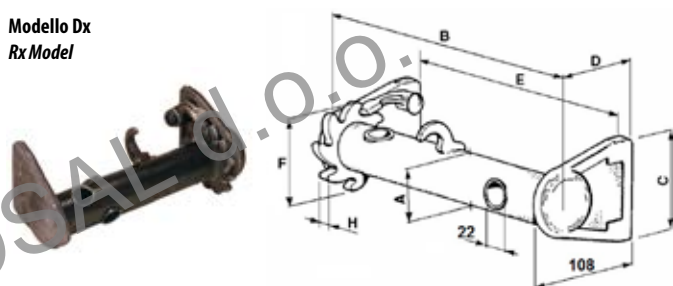

Art./Ref.	Tipo/Type	A mm	B mm	C mm	D mm	E mm	F mm	H mm
03536	Destro/Right	48	275	108	75	225	95	8
03537	Sinistro/Left	48	275	108	75	225	95	8
03538	Destro/Right	60	325	125	86	260	108	10
03539	Sinistro/Left	60	325	125	86	260	108	10

VERRICELLO PER MOTOCULTIVATORE

TREUIL POUR MOTOCULTEUR
WINCH FOR WALKING TRACTOR
SEILWINDE FÜR MOTORHACKE
TORNO PARA MOTOCULTOR



Modello Dx
Rx Model

Art./Ref.	Tipo/Type
03540	Destro/Right
03541	Sinistro/Left

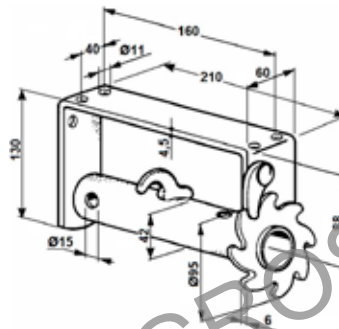
SALTARELLO

TOURILLON
PIN
FALLKLINKE
SALTAREL



Art./Ref.	00612
-----------	-------

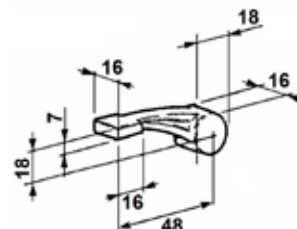

ROSETTA IN LAMIERA STAMPATA

COURONNE DENTÉE EN TOLE
PLATE WHEEL
ZAHNKRANZ AUS STANZBLECH
ARANDELLA DENTELLADA DE CHAPA

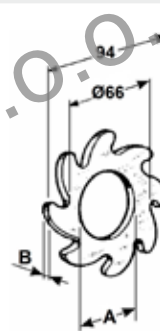

Note: 8 denti
Notes: 8 teeth

Art./Ref.	A mm	B mm
00609	42	5
00610	48	6

ROSETTA IN ACCIAIO STAMPATO

COURONNE DENTÉE EN ACIER
PLATE WHEEL IN STEEL
ZAHNKRANZ AUS STAHL GESCHMIEDET
ARANDELLA DENTELLADA DE ACERO



Art./Ref.	Tipo/Type
00611	11 denti



ROSETTA IN LAMIERA STAMPATA SENZA FORO

COURONNE DENTÉE EN TOLE SANS TROU
 PLATE WHEEL WITHOUT HOLE
 ZAHNKRANZ AUS STANZBLECH OHNE LOCH
 ARANDELLA DENTELLADA DE CHAPA SIN AGUJERO



Art./Ref.	Tipo/Type
14491	8 denti

UNCINO CAPO CATENA

CROCHET BOUT CHAINE
 END HOOK-CHAIN
 ENDEKETTEHAKEN
 GANCHO FIN CADENA

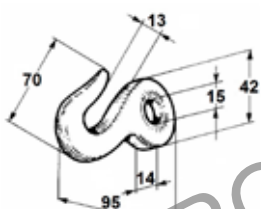

Art./Ref.
02167

GANCIO CATENA

CROCHET CHAINE
 HOOK CHAIN
 KETTEHAKEN
 GANCHO CADENA

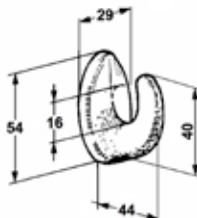

Art./Ref.
02168

ANELLO FERMACARICO

ANELLO FERMACARICO
 ANELLO FERMACARICO
 ANELLO FERMACARICO
 ZURRMULDEN

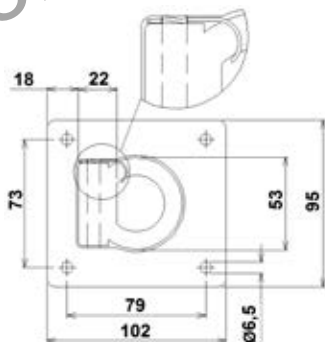

Note: Con molla antirumore.
Notes: With silent spring.

Art./Ref.
59164

TENDIFUNE

TENDEUR DE CORDE
 CABLE TURNBUCKLE
 HAKEN
 GANCHO LIGERO

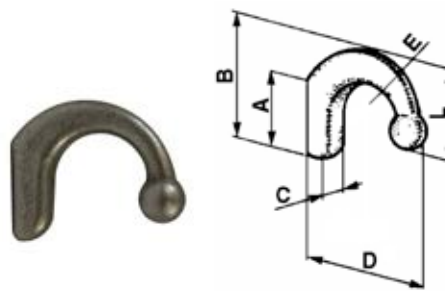

Art./Ref.	Tipo/Type	A mm	B mm	C mm	D mm	E mm	L mm
00622	Leggero/Light +	29	43	13	55	8	40
00623	Pesante/Heavy	38	54	15	60,5	13	54

TENDIFUNE LEGGERO

TENDEUR DE CORDE LEGER
 LIGHT CABLE TURNBUCKLE
 LEICHTER HAKEN
 GANCHO LIGERO

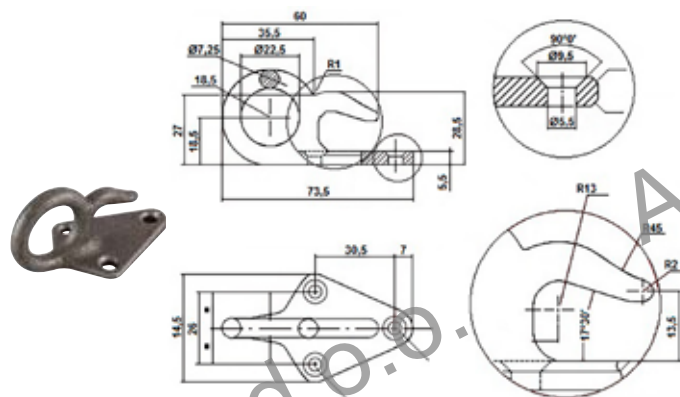

Art./Ref.
59165

TENDICATENA ESTERNO

TENDEUR DE CHAIN EXTERIEUR
 OUTER CHAIN STRETCHER
 HAKENVERSCHLUSS
 TENSOR DE CADENA EXTERCIOR NORMAL

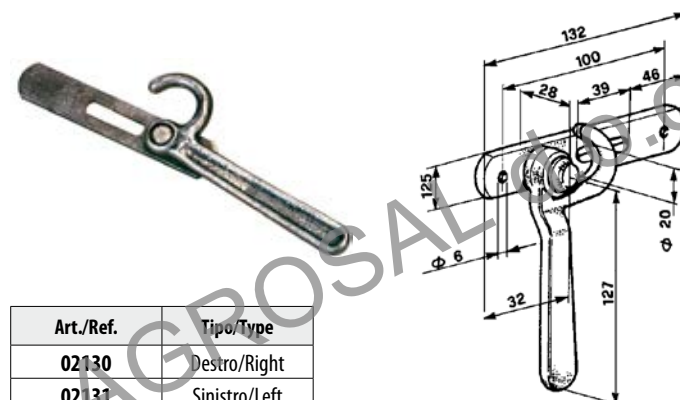

Art./Ref.	Tipo/Type
02130	Destro/Right
02131	Sinistro/Left

LEVA TENDICATENA

LEVIER TENDEUR DE CHAINE
CHAIN STRETCHER LEVER
KETTENSPIANNHEBEL
PALANCA TENSOR DE CADEN

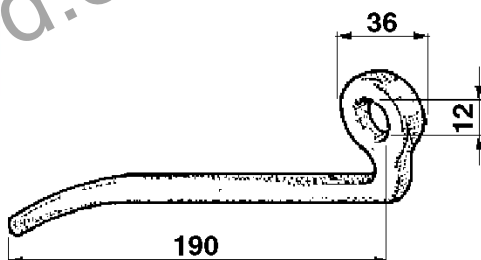

Art./Ref.
00613

FASCE DI ANCORAGGIO IN POLIESTERE

BANDE POUR ANCRER EN POLYESTER
PLYESTER ANCHORAGE BANDS
ZURRGURTE AUS POLYESTERBAND
CINTAS EN POLIESTERE



Art./Ref.	B mm	Portata/Capacità/ Flow/Capacity	Lunghezza mm/ Lenght mm
18735	25	400	5000
18732	25	750	5500
39818	38	1500	6000
67410	50	2500	6000
67411	50	2500	8000
39819	50	2500	9500
67412	50	2500	12000
39820	50	2500	14000
67413	50	2500	20000
39821	75	4000	10000

KIT RIMORCHIO Ø 60

KIT REMORQUE Ø 60

TRAILER KIT Ø 60

KIPPLER-SATZ Ø 60

KIT REMOLQUE Ø 60

PORTATA COMPLESSIVA MAX KG 2.500
MAX CAPACITY 2.500 KG

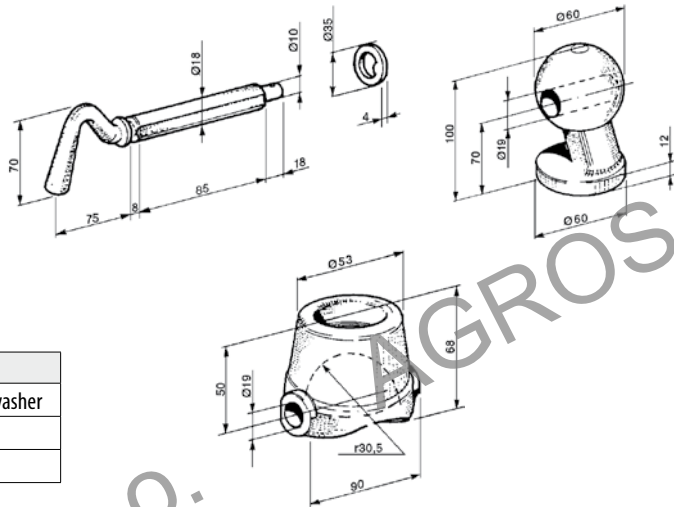

Art./Ref.	Pos.	Note/Note
02985	1	Chiavistello a 1 scanalatura con rondella / 1 groove latchlock with washer
02973	2	Chiocciola agricola Ø 60 / Central ball support Ø 60
02970	3	Sfera agricola Ø 60 a 1 foro / Trailer ball Ø 60 with 1 hole

Art./Ref.	Note/Note
37580	n°2 2985
	n°2 2970
	n°1 2971
	n°2 2974
	n°4 2973
	n°1 2972

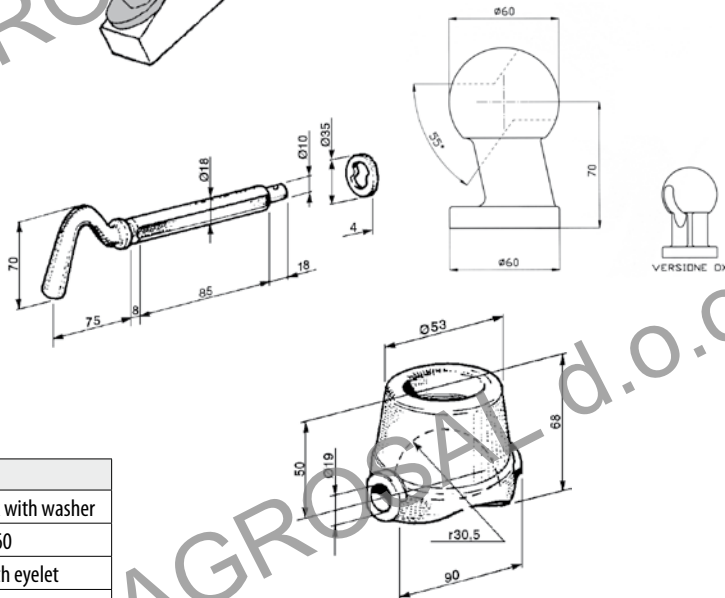
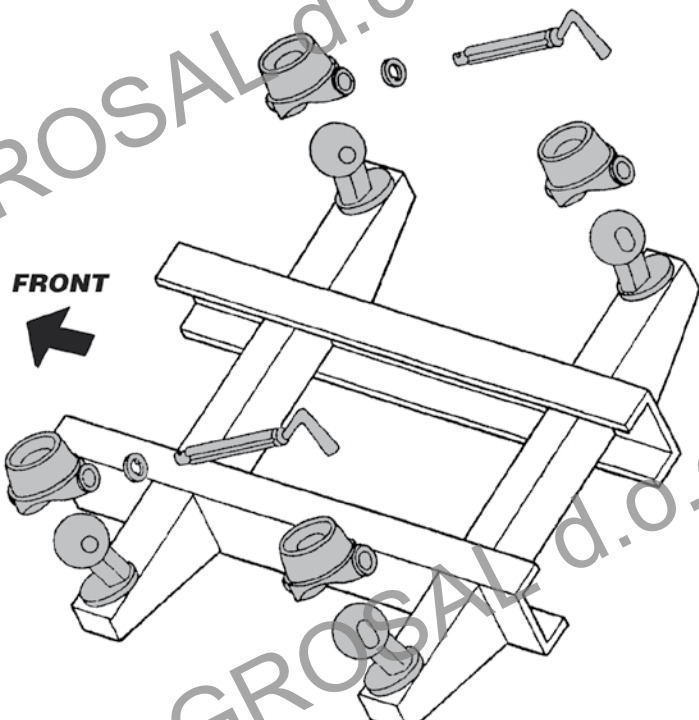

Art./Ref.	Pos.	Note/Note
02974	1	Chiavistello a 2 scanalature con rondella / 2 groove latchlock with washer
02973	2	Chiocciola agricola Ø 60 / Central ball support Ø 60
02972	3	Sfera agricola dx Ø 60 con asola / Trailer ball rh Ø 60 with eyelet
02971	3	Sfera agricola dx Ø 60 con asola / Trailer ball rh Ø 60 with eyelet

KIT RIMORCHIO Ø 78

KIT REMORQUE Ø 78

TRAILER KIT Ø 78

KIPPLAGER-SATZ Ø 78

KIT REMOLQUE Ø 78

PORTATA COMPLESSIVA MAX KG 10.000

MAX CAPACITY 10.000 KG



Art./Ref.	Pos.	Note/Note
00619	1	Chiavistello Ø 15 / Latchlock Ø 15
34902	2	Sfera agricola Ø 78 / Trailer ball Ø 78
34901	3	Chiocciola agricola Ø78 / Central ball support Ø78

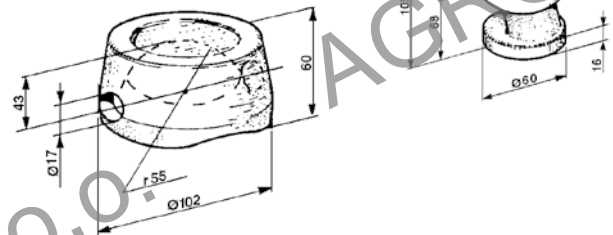
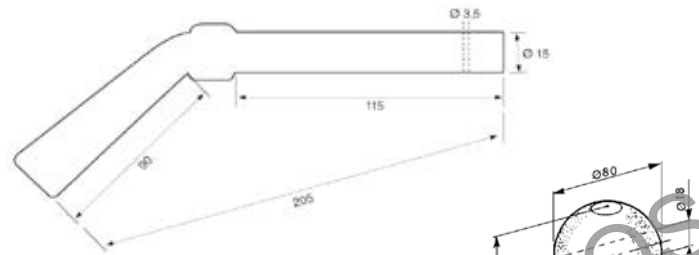

FRONT

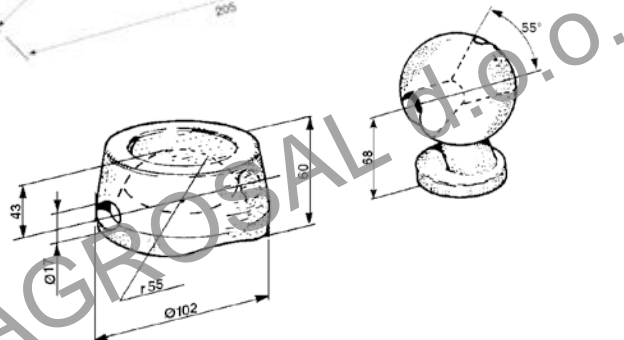
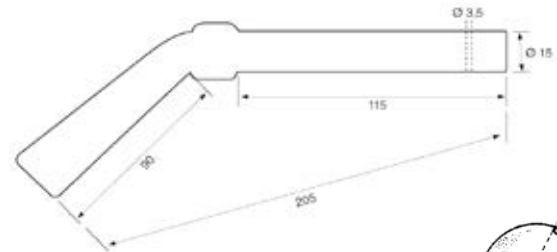
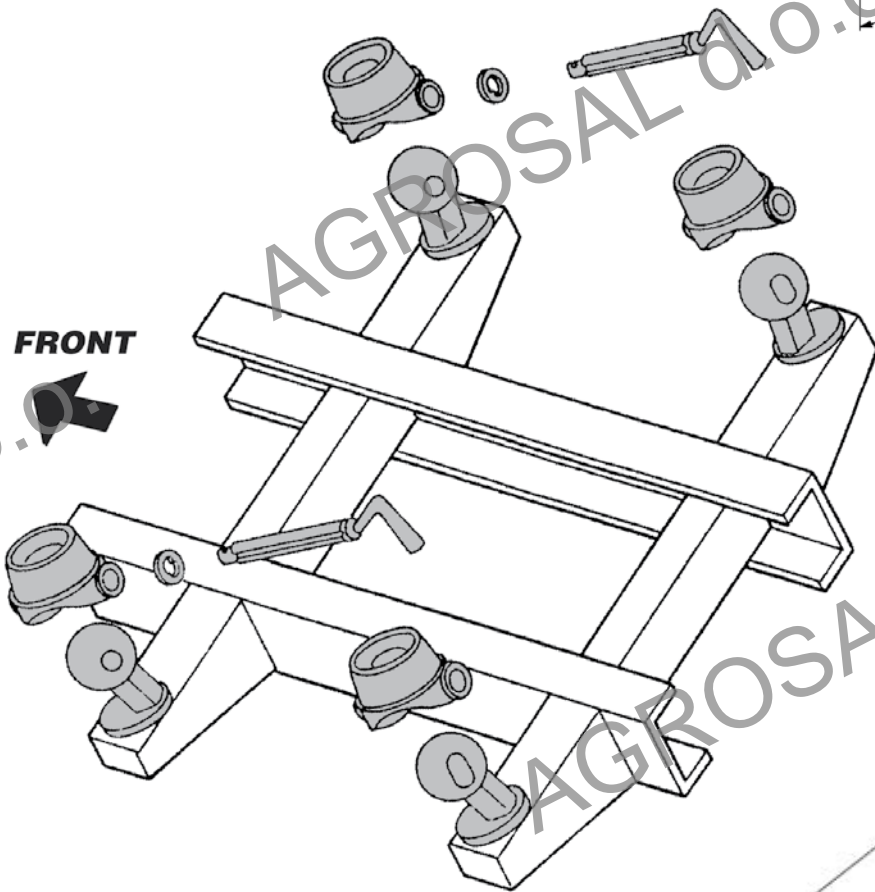

Art./Ref.	Pos.	Note/Note
00619	1	Chiavistello Ø 15 / Latchlock Ø 15
34903	2	Sfera agricola Ø 78 con asola / Trailer ball Ø 78 with eyelet
34901	3	Chiocciola agricola Ø78 / Central ball support Ø78

RALLE A SFERE IN ACCIAIO PER RIMORCHI AGRICOLI

RONDS D'AVANT TRAIN A BILLES

BALL BEARING SLEWING RINGS

KUGELLENKRÄNZE

CORONA CON BOLAS DE ACERO PARA REMOLQUES AGRÍCULOS



Art./Ref.	A mm	B mm	C mm	D mm	E mm	G mm	H mm	I mm	Carico verticale/Vertical load	Peso Kg/Weight Kg
03273	298	293	220	200	270	12	6	55	500	5
00528	400	400	320	300	375	12	6	55	750	8
00529	500	500	420	400	475	12	6	55	1000	10
00530	600	600	516	490	575	14	7	65	1700	18
00532	700	700	620	594	675	14	7	65	2200	22
00534	800	800	718	690	775	14	7	65	2500	26
00536	900	900	820	793	875	14	8	65	3500	30
00538	1000	1000	920	895	975	14	8	65	4000	33
17742	1050	1050	970	945	1025	14	8	65	4500	35
03222	1010	1015	916	888	972	16	9	80	6000	42
03257	1100	1105	1005	976	1060	16	9	80	6500	45

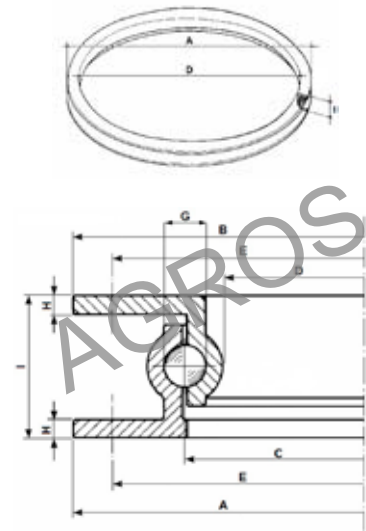

ASSALI E SEMIASSI SENZA FRENO

ESSIEUX ET DEMI - ESSEIEUX SANS FREIN

AXLES AND AXLE SHAFTS WITHOUT BRAKE

ACHSE UND HALBACHSE OHNE BREMSE

EJE Y SEMI - EJE SIN FRENO

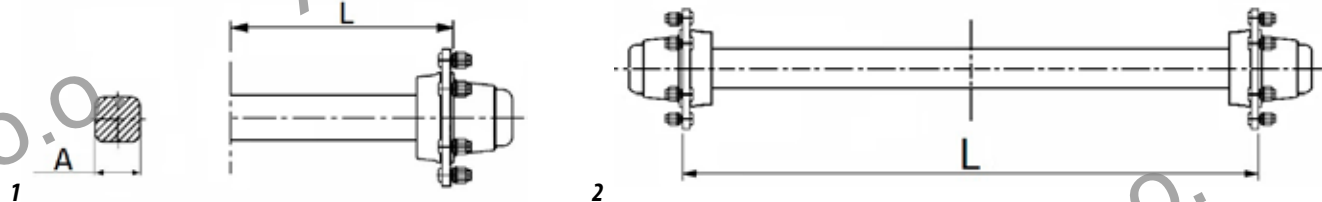

Art./Ref.	Pos.	A mm	L mm	Portata Kg/ Portata Kg	Tipo/Type	Note/Note	Peso Kg/ Weight Kg
11666	1	30	200	300	4 fori Balilla	Cuscinetti: 6204-6205 Ø colonnetta: 12 Interasse fori+battuta disco: 95-62 Velocità max: 40km/h/ Bearings: 6204-6205 Ø colonnetta: 12 Hole wheelbase+disc stroke end: 95-62 Max speed: 40km/h	3,25
11668	1	30	200	300	4 fori Fiat	Cuscinetti: 6204-6205 Ø colonnetta: 12 Interasse fori+battuta disco: 98-58 Velocità max: 40km/h/ Bearings: 6204-6205 Ø colonnetta: 12 Hole wheelbase+disc stroke end: 98-58 Velocità max: 40km/h	3,5
11674	1	35	200	300	4 fori Fiat	Cuscinetti: 6204-6205 Ø colonnetta: 12 Interasse fori+battuta disco: 98-58 Velocità max: 40km/h/ Bearings: 6204-6205 Ø colonnetta: 12 Hole wheelbase+disc stroke end: 98-58 Max speed: 40km/h	3,65
11678	1	40	200	400	4 fori Balilla	Cuscinetti: 6204-6206 Ø colonnetta: 12 Interasse fori+battuta disco: 95-62 Velocità max: 40km/h/ Bearings: 6204-6206 Ø colonnetta: 12 Hole wheelbase+disc stroke end: 95-62 Max speed: 40km/h	4,50
11680	1	40	200	400	4 fori Fiat	Cuscinetti: 6204-6206 Ø colonnetta: 12 Interasse fori+battuta disco: 98-58 Velocità max: 40km/h/ Bearings: 6204-6206 Ø colonnetta: 12 Hole wheelbase+disc stroke end: 98-58 Max speed: 40km/h	4,25
11683	2	40	1200	1500	5 fori	Cuscinetti: 30205-30207 Ø colonnetta: 16 Interasse fori+battuta disco: 140-93 Velocità max: 40km/h/ Bearings: 30205-30207 Ø colonnetta: 16 Hole wheelbase+disc stroke end: 140-93 Max speed: 40km/h	20,80
11684	1	40	200	800	5 fori	Cuscinetti: 30205-30207 Ø colonnetta: 16 Interasse fori+battuta disco: 140-93 Velocità max: 40km/h/ Bearings: 30205-30207 Ø colonnetta: 16 Hole wheelbase+disc stroke end: 140-93 Max speed: 40km/h	7,90
11686	1	45	200	1000	5 fori	Cuscinetti: 30206-30208 Ø colonnetta: 16 Interasse fori+battuta disco: 140-93 Velocità max: 40km/h/ Bearings: 30206-30208 Ø colonnetta: 16 Hole wheelbase+disc stroke end: 140-93 Max speed: 40km/h	8,60
11687	2	50	1400	2500	5 fori	Cuscinetti: 30206-30209 Ø colonnetta: 16 Interasse fori+battuta disco: 140-93 Velocità max: 40km/h/ Bearings: 30206-30209 Ø colonnetta: 16 Hole wheelbase+disc stroke end: 140-93 Max speed: 40km/h	37
11688	1	50	200	1300	5 fori	Cuscinetti: 30206-30209 Ø colonnetta: 16 Interasse fori+battuta disco: 140-93 Velocità max: 40km/h/ Bearings: 30206-30209 Ø colonnetta: 16 Hole wheelbase+disc stroke end: 140-93 Max speed: 40km/h	8,80
11690	1	50	200	1300	6 fori	Cuscinetti: 30206-30209 Ø colonnetta: 18 Interasse fori+battuta disco: 205-160 Velocità max: 40km/h/ Bearings: 30206-30209 Ø colonnetta: 18 Hole wheelbase+disc stroke end: 205-160 Max speed: 40km/h	13
11692	1	60	200	2000	6 fori	Cuscinetti: 30208-30211 Ø colonnetta: 18 Interasse fori+battuta disco: 205-160 Velocità max: 40km/h/ Bearings: 30208-30211 Ø colonnetta: 18 Hole wheelbase+disc stroke end: 205-160 Max speed: 40km/h	15

ASSALI E SEMIASI CON FRENO IN FERRO

ESSIEUX ET DEMI - ESSEIEUX AVEC FREIN EN FER
 AXLES AND AXLE SHAFTS WITH BRAKE MADE OF IRON
 ACHSE UND HALBACHSE MIT EISENBREMSE
 EJE Y SEMI - EJE CON FRENO DE HIERRO

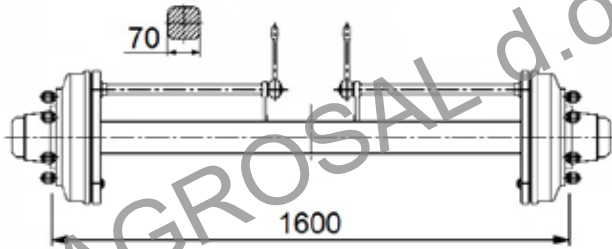

Art./Ref.	Portata Kg/Portata Kg	Tipo/Type	Note/Note	Peso Kg/Weight Kg
11715	6000	6 fori	Cuscinetti: 30209-32212 Ø freno: 300x60 Interasse fori+battuta disco: 205-160. Velocità max: 40 km/h./ Bearings: 30209-32212 Ø brake: 300x60 Hole wheelbase+disc stroke end: 205-160. Max speed: 40 km/h.	120

CATENE PASSO 80

CHAINE PAS 80
 80 PITCH CHAIN
 KETTE TEILUNG 80
 PASO CADENAS 80

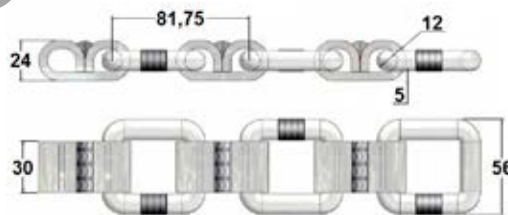

Note: Caratteristiche: Per impiego su tappeti di carri spandiletame, foraggiere, autocaricanti e qualsiasi trasporto a bassa velocità che richieda robustezza e durata.

Nota: giunti non inclusi

Notes: Characteristic: For use on manure-spreaders, forage-harvesters, self-loader trucks mats and any low speed conveyor where toughness and duration are required.

Note: joints not included

Art./Ref.	Note/Note	Lunghezza mm/Lenght mm	Tipo/Type
75404	Rotolo catena	100,3 mt	80/12
75209	1 mazzo a 2 catene / Carico di rottura 6.500kg	8,75 mt	80/12
75210	1 mazzo a 2 catene / Carico di rottura 6.500kg	10,75 mt	80/12
75211	1 mazzo a 3 catene / Carico di rottura 6.500kg	8,75 mt	80/12
75212	1 mazzo a 3 catene / Carico di rottura 6.500kg	10,75 mt	80/12
75213	1 mazzo a 3 catene / Carico di rottura 9.000kg	12,50 mt	80/12/X

GIUNTI PER CATENA

JOINTS POUR CHAINE
 CHAIN JOINT
 KETTENGLIEDER
 JUNTAS PARA CADENA

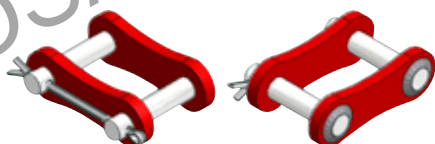

Art./Ref.	Tipo/Type	Brand	Applicazione/Application
75214	80/12	A.M.A.	75209, 75210, 75211, 75212

1.1.2 Componenti per carri botte

Components for slurry



ama

Ricambi & accessori per macchine agricole

SPARE PARTS & ACCESSORIES FOR AGRICULTURAL MACHINE

Tutti gli articoli della presente sezione, prodotti da AMA SPA e/o da terzi per conto di AMA, sono adattabili ("non originali") alle marche indicate ai sensi di quanto previsto dal REG. CE n. 1400/2002. I diritti sui marchi citati appartengono ai legittimi proprietari ed il loro uso ha l'esclusiva finalità di consentire all'utilizzatore la comparazione dei diversi prodotti. All items of this section, manufactured by AMA SPA and/or any third party on behalf of AMA, are adaptable ("non-original") to the brands listed under the provisions of the REG. CE n. 1400/2002. The rights on the trademarks belong to their respective owners and their usage is only aimed to allow the user to compare different products.

TUBO DI ASPIRAZIONE IN PVC

TUYAU ASPIRATION EN PVC
SLURRY TANK HOSE PVC
SPIRALSCHLAUCH AUS PVC
TUBO DE ASPIRACIÓN DE PVC



Note: Tubo flessibile in PVC rigido antiurto plastificato con spirale di rinforzo (liscio internamente). Ideale per aspirazione e mandata su carri botte per irrigazione, spurghi fognatura e pozzi neri e per tutti gli impieghi medio pesanti dell'industria in genere. La facilità di scorrimento è garantita dalla presenza di una pellicola esterna antiabrasiva. Temperatura di utilizzo da -10°C a +50°C

Notes: Plasticized PVC flexible hose with rigid shock-resistant PVC reinforcement spiral (Smooth inside). Ideal for suction and delivery of liquids on tank trucks for irrigation, sewerage and cesspool cleaning and for all medium duty applications of industry in general. Easy sliding is guaranteed by an external anti-abrasive film. Working temperature from -10°C to +50°C

Art./Ref.	Pressione nominale/ Nominal pressure	Diametro interno mm/ Inside diameter mm	Diametro esterno mm/ Outside diameter mm	Lunghezza Mt/ Length Mt
04873	3,5	80	93	30
04842	3	100	114	30
04874	3	110	124,4	20
04843	2,5	120	136	20
04844	2	150	166	20
56766	2	150	166	4,6

FASCETTE STRINGITUBO PER CARRIBOTTE

COLLIERS DE SERRAGE POUR TONNES A LISIER
HOSE CLIPS FOR SLURRY TANKS
SCHLAUCHSCHELLEN FÜR GÜLLEWAGEN
ABRAZADERA DE TUBO PARA CISTERNA



Art./Ref.	Diametro mm/ Diameter mm	Larghezza mm/ Width mm	Spessore mm/ Thickness mm
02617	60-63	22	1,2
02619	68-73	24	1,5
02640	86-91	24	1,5
02642	92-97	24	1,5
02643	98-103	24	1,5
02645	113-121	24	1,5
02646	122-130	24	1,5
02647	131-139	26	1,7
02648	140-148	26	1,7
02649	149-161	26	1,7
02663	175-187	26	1,7
02679	214-226	26	1,7

TUBO DI ASPIRAZIONE IN GOMMA

TUYAU CAOUTCHOUC
BLACK SLURRY TANK RUBBER HOSE
SPIRALGUMMISCHLAUCH
TUBO DE ASPIRACIÓN DE / GOMA



Art./Ref.	Diametro interno mm/ Inside diameter mm	Diametro esterno mm/ Outside diameter mm	Lunghezza Mt/ Length Mt
02711	80	97	2
02712	100	120	2
02713	120	140	2
02714	150	175	2
02789	100	120	3
02710	120	140	3
02715	150	175	3

TUBO DI ASPIRAZIONE CON PORTAGOMMA ZINCATO

TUBE GALVANISE PLONGEUR
GALVANIZED SLURRY TANK PIPE
VERZINKTER ANSAUGROHR
TUBO DE ASPIRACIÓN



Art./Ref.	Diametro mm/ Diameter mm	Lunghezza Mt/ Length Mt
03168	100	2
03169	120	2
03170	150	2
03193	200	2
03175	100	3
03176	120	3

TUBO DI ASPIRAZIONE CON GIUNTO SFERICO MASCHIO E ANELLO ZINCATI

TUBE GALVANISE PLONGEUR
GALVANIZED SLURRY TANK PIPE
VERZINKTER ANSAUGROHR
TUBO DE ASPIRACIÓN CINCADO



Note: Lunghezza: 3 mt

Notes: Length: 3 mt

Art./Ref.	Diametro mm/ Diameter mm
03172	100
03181	120
03182	150
03619	200

TRONCHETTO FILETTATO GREZZO

MANCHON FILETEE
TREATED TUBE
GEWINDESTUTZ
TUBO ROSCADO



Art./Ref.	Diametro mm/Diameter mm	Lunghezza mm/Lenght mm	Filettatura/Thread
03062	60	70	2"
03063	80	70	3"
03076	100	70	4"
03077	120	100	5"
03078	150	100	6"
03225	100	150	4"
03226	120	150	5"
03203	150	150	6"

CHIUSURA PER FONDO APRIBILE

FERMETEURE POUR TONNE A LISIER
CLOSING DEVICE FOR SLURRY TANK
VERSTELLBARER VERSCHLUSS
CIERRE PARA CISTERNA

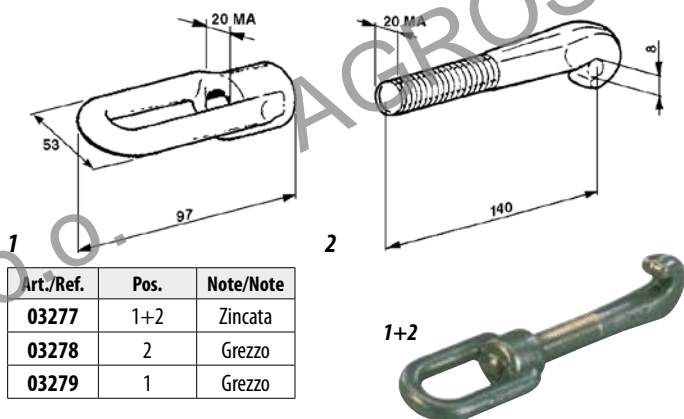

Art./Ref.	Pos.	Note/Note
03277	1+2	Zincata
03278	2	Grezzo
03279	1	Grezzo

CHIUSURA FONDO CARRO BOTTE

FERMETEURE TONNE A LISIER
SLURRY TANK CLOSING
VERSTELLBARER TANKWGEN
CIERRE PARA CISTERNA

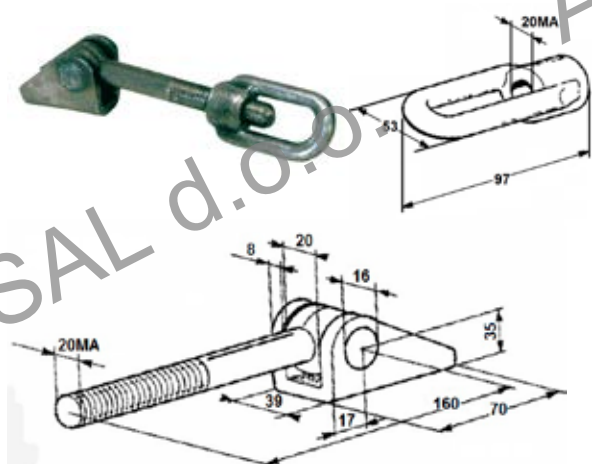

Art./Ref.
03013

ORECCHIO PER CHIUSURA ART. 03013

OREILLE POUR FERMETEURE REF. 03013
CLOSURE EXTENSION FOR REF. 03013
LASCHE FÜR VERSCHLUSS ART. 03013
PARTE PARA CIERRE ART. 03013

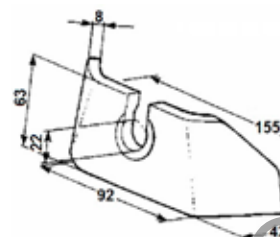

Art./Ref.
31203

VALVOLE DI FONDO CON PORTAGOMMA

CLAPET DE FOND AVEC PORTE TUYAU
FOOTVALVES WITH HOSE TAIL
BODENVENTIL MIT VERSCHRAUBUNG
VALVULA INFERIOR PORTAMANGUERA



Art./Ref.	Diametro mm/Diameter mm
73455	100
73456	120

VALVOLE DI FONDO CON SFERA

CLAPET DE FOND AVEC SPHERE
FOOTVALVES WITH QUICK RELEASE COUPLING
BODENVENTIL MIT KUGEL
VALVULAS PARTE INFERIOR CON ESFERA



Art./Ref.	Diametro mm/Diameter mm
73457	100
73458	120
73459	150

RACCORDO SFERICO COMPLETO CON GUARNIZIONE

JOINT SPHERIQUE COMPLET
SPHERICAL JOINT
GELENKUGEL
JUNTA ASFÉRICA COMPLETA CON GUARNICIÓN



Art./Ref.	Diametro mm/Diameter mm
05320	60
05321	80
05322	100
05323	120
05324	150
05325	200

ANELLO PER GIUNTO GREZZO

BAGUE POUR JOINT
RING FOR JOINT
RING FÜR GELENKUGEL
ANILLO PARA JUNTA



Art./Ref.	Diametro mm/Diameter mm
04004	80
04007	100
04010	120
04013	150

SFERA PER GIUNTO GREZZA

SPHERE POUR JOINT BRUTE
ROUGH BALL FOR JOINT
ROH KUPPLUNGSKUGEL
BOLA PARA JUNTA BRUTA



Art./Ref.	Diametro mm/Diameter mm
04000	60
04003	80
04006	100
04009	120
04012	150
04569	200

TAPPO CONTROSFERA GREZZO

BOUCHON A GRIFFE BRUT
ROUGH COUPLING
ROH KUPPLUNG GEGENKUGEL
TAPON CONTRA-BOLA BRUTO



Art./Ref.	Diametro mm/Diameter mm
03061	60
03067	80
03068	100
03163	120
03164	150
03165	200

CONTROSFERA GREZZA

BAGUE A CROCHETS
AGAINSTBALL ROUGH
KUPPLUNGSGELENKUGEL
CONTRA - BOLA BRUTA



Art./Ref.	Diametro mm/Diameter mm
04002	60
04005	80
04008	100
04011	120
04014	150
04018	200

TAPPO MASCHIO ZINCATO

BOUCHON A SPHERE
GALVANIZED MALE CAP
BLINDKAPPE KUGELANSCHLUSS
TAPÓN MASCULINO CINCADO



Art./Ref.	Diametro mm/Diameter mm
03105	100
03106	120
03107	150

CONTROSFERA CON TRONCHETTO PORTAGOMMA ZINCATA

MANCHON AVEC GRIFFE
FEMALE CONNECTION FOR HOSE
MUTTERTEIL MIT GEWINDESTUTZ
SEMI JUNTA HEMBRA CINCADA



Art./Ref.	Diametro mm/Diameter mm
08005	60
08006	80
03185	100
03186	120
03187	150
03490	200

SFERA E ANELLO CON TRONCHETTO PORTAGOMMA ZINCATA

MANCHON AVEC SPHERE
MALE CONNECTION FOR HOSE
VATERTEIL FÜR SCHLAUCH
SEMIJUNTA MACHO CINCADA Y CON SEPARADOR PARA TUBO DE GOMA



Art./Ref.	Diametro mm/Diameter mm
08007	60
08008	80
03178	100
03179	120
03180	150
04571	200

CONTROSFERA CON TRONCHETTO FILETTATO ZINCATO

RACCORD FEMELLE
FEMALE CONNECTION WITH FEMALE THREAD
GEWINDESTUTZ MIT BECHERANSCHLUSS
SEMIJUNTA FILETEADA HEMBRA



Art./Ref.	Diametro mm/Diameter mm	Filettatura/Thread
03160	100	4"
03315	120	4"
03161	120	5"
03316	150	5"
03162	150	6"

SFERA E ANELLO CON TRONCHETTO FILETTATO ZINCATO

SPHERE AVEC FILETAGE
BALL MALE WITH THREAD CONNECTION
GEWINDESTUTZ MIT KUGELANSCHLUSS
CONTRA - BOLA MACHO CON FILETE



Art./Ref.	Diametro mm/Diameter mm	Filettatura/Thread
03143	100	4"
03144	120	5"
03145	150	6"
03349	200	8"

RIDUZIONE CONICA CON GIUNTO SFERICO ZINCATA

REDUCTION ZINGUEE
GALVANIZED RIDUCTION BALL-FEMALE
KEGELKUPPLUNG MIT KEGELANSCHLUSS
REDUCCIÓN CINCADA MACHO - HEMBRA



Art./Ref.	Diametro mm/Diameter mm
03082	M 150 x F 100
03080	M 150 x F 120

CONO LISCIO GREZZO

CONE LISSE BRUT
CONUS NOT GALVANIZED
KONUSSE ROHSTEIL
CONO LISO BRUTO



Note: Spessore: 2 mm
Notes: Thickness: 2 mm

Art./Ref.	Diametro mm/Diameter mm
03150	50 - 100
03151	50 - 120
03152	50 - 150
04687	60 - 200

SFERA ZINCATA CON CONO

SPHERE ZINGUÉE AVEC CONE
GALVANISED BALL WITH CONUS
KUGEL VERZINKT MIT SCHWINGHEBEL
ESFERA CINCADA CON CONO

Art./Ref.	Diametro mm/Diameter mm
03190	100
03191	120
03192	150

FILETTATO ZINCATO

MANCHON FILETÉ AVEC FEMELLE ZINGUÉE
GALVANISED FEMALE WITH THREADED STUB-PIPE
GEWINDESTUTZ BECHER VERZINKT MIT GUMMIRING
CONTRA BOLA CON TUBO ROSCADO Y CINCADO



Note: Tipo Bauer. Completo di guarnizione.

Notes: Bauer type. Complete with gasket.

Art./Ref.	Diametro mm/Diameter mm	Filettatura/Thread
14733	50	1 1/2"
14734	50	2"
14735	76	2 1/2"
14736	76	3"
14737	89	3"
14738	108	4"
14739	133	5"
14740	159	6"
14741	194	8"

SFERA E BILANCERE ZINCATI CON TRONCHETTO FILETTATO

RACCORD ZINGUÉE AVEC MANCHÓN FILETÉE BALANCER
GALVANISED BALL AND BALANCER WITH THREAD END
VERZINKTE V-TEIL MIT GEWINDESTUTZEN
ESFERAS Y BALANCINES CINCADOS CON TRONCO ROSCADO



Note: Tipo Bauer.

Notes: Bauer type.

Art./Ref.	Diametro mm/Diameter mm	Filettatura/Thread
14724	50	1 1/2"
14725	50	2"
14726	76	2 1/2"
14727	76	3"
14728	89	3"
14729	108	4"
14730	133	5"
14731	159	6"
14732	194	8"

CONTROSFERA CON TRONCHETTO PORTAGOMMA ZINCATA

MACHIN POUR TUYAU SOUPLE AVEC FEMELLE ZINGUÉE
GALVANISED FEMALE WITH STUB-PIPE FOR RUBBER HOSE
VERZINKTE GEGENKUGEL MIT STUTZEN FÜR GUMMIRÖHRE
CONTRA BOLA CINCADA CON TUBO PORTAGOMA

Note: Tipo Bauer.

Notes: Bauer type.

Art./Ref.	Diametro mm/Diameter mm
14713	50 x 50
14714	76 x 63
14715	76 x 76
14716	89 x 76
14717	89 x 89
14718	108 x 100
14719	108 x 108
14720	133 x 125
14721	159 x 150
14722	159 x 159
14723	194 x 200

SFERA E ANELLO CON TRONCHETTO PORTAGOMMA ZINCATO

MANCHON POUR TUYAU SOUPLE AVEC SPHER ZINGUÉE
GALVANISED BALL WITH STUB-PIPE FOR RUBBER HOSE
VERZINKTE KUGEL MIT STUTZEN FÜR GUMMIRÖHRE
BOLA Y ANILLO CINCADOS TUBO POTAGOMA

Note: Tipo Bauer.

Notes: Bauer type.

Art./Ref.	Diametro mm/Diameter mm
14702	50 x 50
14703	76 x 63
14704	76 x 76
14705	89 x 76
14706	89 x 89
14707	108 x 100
14708	108 x 108
14709	133 x 125
14710	159 x 150
14711	159 x 159
14712	194 x 200

RACCORD SFERICO COMPLETO CON GUARNIZIONE

JOINT SPERIQUE COMPLETE
COMPLETE SHPERIC JOINT
GEWINDESTUTZ KUGEL MIT GUMMIRING
JUNTA ASFERICA COMPLETA CON GUARNICION

Note: Tipo Bauer.

Notes: Bauer type.

Art./Ref.	Diametro mm/Diameter mm
14653	50
14654	76
14655	89
14656	108
14657	133
14658	159
14659	194



SFERA PER GIUNTO GREZZA

SPHERE POUR JOINT BRUTE
ROUGH BALL FOR JOINT
ROH KUPPLUNGSKUGEL
BOLA PARA JUNTA BRUTA

Note: Tipo Bauer.
Notes: Bauer type.

Art./Ref.	Diametro mm/Diameter mm
14660	50
14661	76
14662	89
14663	108
14664	133
14665	159
14666	194



TAPPO CON POS'ERA

BOUCHON A GRIFFE ZINGUE'
GALVANIZED COUPLING
VERZINKT KUPPLUNG GEGENKUGEL
TAPON CONTRA BOLA CINCADO

Note: Tipo Bauer.
Notes: Bauer type.

Art./Ref.	Diametro mm/Diameter mm
14695	50
14696	76
14697	96
14698	108
14699	133
14700	159
14701	194



BILANCIERE ZINCATO

BASCULAT ZINGUE'
GALVANIZED BALANCER
VERZINKTE SCHWINGHEBEL
CONTRA BOLA CINCADA

Note: Tipo Bauer.
Notes: Bauer type.

Art./Ref.	Diametro mm/Diameter mm
14674	50
14675	76
14676	89
14677	108
14678	133
14679	159
14680	194



SFERA ZINCATA CON CONO

SPHERE ZINGUEE AVEC CONE
GALVANISED BALL WITH CONE
KUGEL VERZINKT MIT SCHWINGHEBEL
ESFERA CINCADA CON CONO

Note: Tipo Bauer.
Notes: Bauer type.

Art./Ref.	Diametro mm/Diameter mm
14750	108
14751	133
14752	159



ANELLO PER GIUNTO GREZZO

BAGUE POUR JOINT
RING FOR JOINT
RING FÜR GELENKUGEL
ANILLO PARA JUNTA

Note: Tipo Bauer
Notes: Bauer type

Art./Ref.	Diametro mm/Diameter mm
14667	50
14668	76
14669	89
14670	108
14671	133
14672	159
14673	194



CURVA 45° ZINCATA CON GIUNTO SFERICO

COURBE 45° AVEC GRIFFE ET SPHERE
BEND 45°
45° KPL. BOGENSTÜCK
CURVA 45° CINCADA MACHO - HEMBRA

Art./Ref.	Diametro mm/Diameter mm
03702	100
03703	120



CURVA 90° CON GIUNTO SFERICO ZINCATA

COURBE 90° AVEC GRIFFE ET SPHERE
BEND 90°
KPL. BOGENSTÜCK
CURVA 90° CINCADA



Art./Ref.	Diametro mm/Diameter mm
03075	100
03079	120
03083	150

CURVA A 90° CON CONO E CONTROSFERA ZINCATA

COURBE 90° AVEC CONE ET GRIFFE
GALVANIZED 90° BEND
ROHRBOGEN 90° MIT DÜSE
CURVA 90° HEMBRA CON CONO



Art./Ref.	Diametro mm/Diameter mm
03100	100
03101	120
03102	150
04630	200

CURVA A 90° CON CONO E SFERA ZINCATA

COURBE 90° AVEC CONE
BEND 90° WITH MALE END CONUS
ROHRBOGEN 90° MIT DÜSE
CURVA 90° MACHO CON CONO



Art./Ref.	Diametro mm/Diameter mm
03156	120
03157	150
04650	200

CURVA A 90° LISCIA CREZZATA

COURBE LISSE 90° BRUTE
90° BAND NOT GALVANIZED
ROHRBOGEN 90°
CURVA 90° LISA Y BRUTA



Note: Spessore: 1,2 mm
Notes: Thickness: 1,2 mm

Art./Ref.	Diametro mm/Diameter mm	Spessore mm/Thickness mm
03109	100	1.2
03110	120	1.2
03111	150	1.2

DIFFUSORE A VENTAGLIO CIRCOLARE ZINCATO

PALETTE COUPE JET
CIRCULAR SPREAPER
VERTEILER
ASPERSOR CIRCULAR



Art./Ref.
03166

DIFFUSORE A VENTAGLIO ZINCATO CON CONTROSFERA E CONO IN GOMMA

BUSE AU RAS DE SOL FEMELLE
FEMALE SPLASHER FOR RUBBER CONE
VERTEILER MIT ANSCHLUSS
ASPERSOR CON SEMIJUNTA HEMBRA



Art./Ref.	Diametro mm/Diameter mm
03173	150

CURVA ZINCATA CON CONTROSFERA E CONO IN GOMMA Ø 150 MM

COURBE ZINGUÉE CONTRE-SPHERE ET CONE Ø 150 MM.
 GALVANIZED CURVE WITH BALL & CONE Ø 150 MM.
 BOGEN VERZINKT MIT GEGENKUGEL Ø 150 MM.
 CURVA CINCADA CON SEMIJUNTA HEMBRA Ø 150 MM.



Art./Ref.
34610

CURVA ZINCATA CON SFERA E CONO IN GOMMA Ø 150 MM

COURBE ZINGUÉE CONTRE-SPHERE ET CONE Ø 150 MM.
 GALVANIZED CURVE WITH BALL & CONE Ø 150 MM.
 BOGEN VERZINKT MIT GEGENKUGEL UND KONUS Ø 150 MM.
 CURVA CINCADA CON ESFERA Y CONO Ø 150 MM.



Art./Ref.
34611

DIFFUSORI TIPO FRANCIA CON SFERA E ANELLO ZINCATO

BUSE D'EPANDAGE AU RAS DU SOL
 SPLASHER
 VERTEILER
 ASPERSOR TIPO "FRANCIA"



Art./Ref.	Diametro mm/Diameter mm
03208	150

CURVA 90° ZINCATA CON GIUNTO SFERICO

COURBE 90° AVEC GRIFFE ET SPHERE
 BEND 90°
 90° KPL. BOGENSTÜCK
 CURVA 90° CINCADA MACHO - HEMBRA



Note: Tipo Bauer.
Notes: Bauer type.

Art./Ref.	Diametro mm/Diameter mm
14688	50
14689	76
14690	89
14691	108
14692	133
14693	159
14694	194

CURVA A 90° CON CONO E SFERA ZINCATA

COURBE 90° AVEC CONE ET SPHERE ZINGUÉE
 GALVANIZED 90° ELBOW WITH CONE AND BALL
 VERZINKTE KURVE 90° MIT KEGEL UND KUGEL
 CURVA 90° CON CONO Y BOLA CINCADA



Note: Tipo Bauer.
Notes: Bauer type.

Art./Ref.	Diametro mm/Diameter mm
14746	108
14747	133
14748	159
14749	194

DIFFUSORE A VENTAGLIO CIRCOLARE CON ASTA ZINCATO

PALETTE COUPE JET CISCOILAIRE AVEC ASTE
 CIRCULAR SPREADER
 VERTEILER MIT STAB
 ASPERSOR CIRCULAR CINCADO CON ASTA



Note: Tipo Bauer.
Notes: Bauer type.

Art./Ref.
14652

GUARNIZIONE IN GOMMA PER GIUNTO SFERICO

JOINTS CAOUTCHOUC
COUPLING GASKET
KUPPLUNGSDICHTUNG
GUARNICIÓN EN GOMA PARA JUNTA ESFÉRICA



Art./Ref.	Diametro mm/Diameter mm	Diametro tubo mm/Hose diameter mm	A mm
03093	85	60	9,8
03094	105	80	11,8
03095	123	100	11,8
03096	141	120	15,2
03097	175	150	15,4
03098	235	200	18

GUARNIZIONE RAPIDA PER GIUNTO IDRAULICO TIPO BICCHIERE

JOINT RAPIDE POUR JOINT HYDRAULIQUE
SAFETY JOINT
SICHERHEITSKUPPLUNGSDICHTUNG
GUARNICIÓN RÁPIDA PARA JUNTA HIDRÁULICA TIPO "VASO"

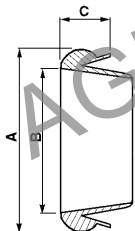

Art./Ref.	Diametro tubo mm/Hose diameter mm	A mm	B mm	C mm
03195	80	102	82	22
03197	100	123	103	23,5
03196	120	147	124	27
03201	150	180.5	155.5	28
03202	200	232	202	31

GUARNIZIONE IN GOMMA PER GIUNTO SFERICO

JOINTS CAOUTCHOUC
COUPLING GASKET
KUPPLUNGSDICHTUNG
GUARNICIÓN EN GOMA PARA JUNTA ESFÉRICA

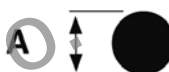

Note: Tipo Bauer
Notes: Bauer type

Art./Ref.	Diametro mm/Diameter mm	Diametro tubo mm/Hose diameter mm	A mm
14681	62	50	9,5
14682	85	76	13
14683	109	89	13
14684	137	108	14
14685	152	133	18
14686	166	159	19

FLANGIA QUADRA CON TRONCHETTO FILETTATO ZINCATA

MANCHON FILETE AVEC FLASQUE ZINGUEE
GALVANISED THREADED STUBPIPE WITH FLANGE
VERZINKTE FLANSCH MIT ASSERGEWINDE
COLLAR CUADRO CON TUBO ROSCADO CINCADO



Art./Ref.	Diametro mm/Diameter mm	Filettatura/Thread
03709	100	4"
03710	120	5"
03711	150	6"
04689	200	8"

FLANGIA ROTONDA CON SFERA E ANELLO ZINCATA

FLASQUE RONDE AVEC SPHERE ET BAGUE ZINGUEE
ROUND FLANGE WITH GALVANIZED SPHERE AND RING
RUNDER FLANSCH MIT VERZINKTER KUGEL UND RING
COLLAR REDONDO CINCADO CON BOLA Y ANILLO



Art./Ref.	Diametro mm/Diameter mm
04697	200

MEC 4000 - 5000 - 8000 POMPE PER VUOTO/PRESSIONE A PALETTE RAFFREDDATE AD ARIA

MEC 4000 - 5000 - 8000 POMPES À VIDE/PRESSION À PALETTES REFROIDIES À AIR

MEC 4000 - 5000 - 8000 AIR COOLED - ROTARY VANES VACUUM/PRESSURE PUMPS

MEC 4000 - 5000 - 8000 PUMPE FÜR VAKUUM/DRUCK MIT SCHIEBER, DIE DURCH LUFT GEKÜHLT WERDEN

MEC 4000 - 5000 - 8000 BOMBAS DE VACÍO/PRESIÓN DE PALETAS REFRIGERADAS POR AIRE



1 3/8" - ISO 500-1

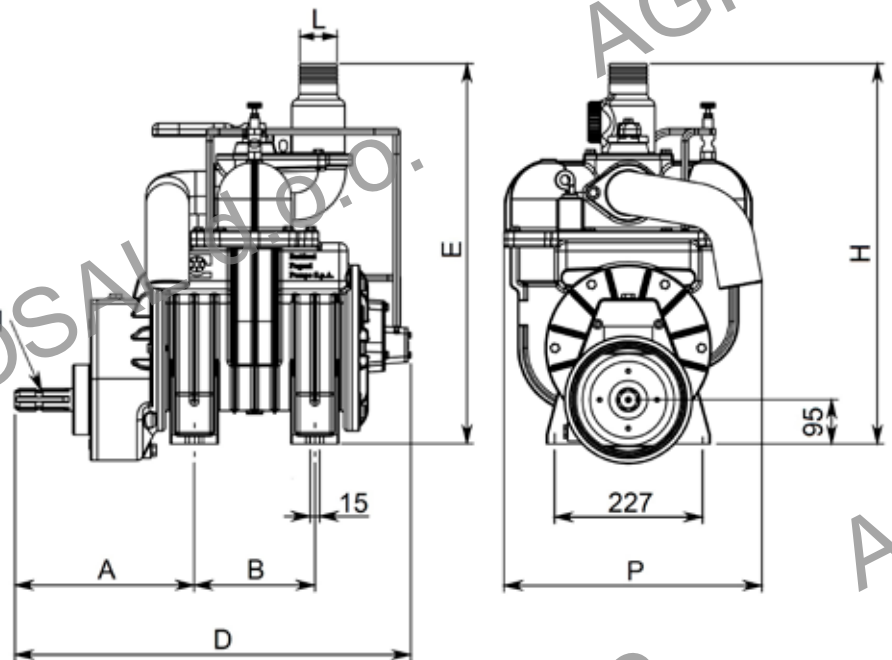

Note: Versione standard adatta ad utilizzi non intensi, di breve durata e non frequenti. La presa di forza è azionata tramite albero cardanico a 540 rpm. La versione è riconoscibile dalla scatola moltiplicatore posta nella parte anteriore della pompa per vuoto rotativa a palette, dalla targhetta d'identificazione.

La lubrificazione avviene sia nella fase di aspirazione che nella fase di compressione tramite una pompa ad ingranaggi posta nella parte posteriore e azionata dall'albero rotore. La pompa ad ingranaggi aspira l'olio dal serbatoio e lo invia al rubinetto di dosaggio a regolazione manuale. L'olio eccedente ritorna al serbatoio stesso.

Notes: Version with standard blades that are suitable for no-strong uses, for short and not frequent periods. The power take-off is actuated through a cardan shaft at 540 r.p.m. This version can be recognised by the gearbox placed at the front of the Rotary blades vacuum pump and by the identification plate.

Lubrication runs during both sucking and compression phase thru a gear pump activated by rotary shaft. Gear pump sucks oil from tank and and send it to the manual-regulated dosing tap. Exceeding oil goes back in the tank.

Art./Ref.	A mm	B mm	D mm	E mm	H mm	L mm	P mm	Peso Kg/Weight Kg	Note/Note
67910	271	189	602	480	525	60	342	100	MEC 4000
67911	279	189	621	597	623	60	410	130	MEC 5000
67912	313	252	761	597	623	80	410	160	MEC 8000

Art. Ref.	Capacità geometrica Geometrical capacity			Max rpm	Max pressione ata Max abs pressure Bar (PSI)	Aspirazione max Max vacuum % (inHg)	Max aspirazione continua Max continuous vacuum % (inHg)	Potenza all'aspirazione max Power at max vacuum kW (HP)
	m ³ /h	l/min	cfm					
67910	261	4350	154	600	2,5 (36)	94 (28,0")	60 (18")	9 (12,6)
67911	369	6150	217					11 (14,7)
67912	486	8100	286					16 (21,4)

MEC 9000 - 11000 - 13500 POMPE PER VUOTO/PRESSIONE A PALETTE RAFFREDDATE AD ARIA

MEC 9000 - 11000 - 13500 POMPES À VIDE/PRESSION À PALETTES REFROIDIES À AIR

MEC 9000 - 11000 - 13500 AIR COOLED - ROTARY VANES VACUUM/PRESSURE PUMPS

MEC 9000 - 11000 - 13500 PUMPE FÜR VAKUUM/DRUCK MIT SCHIEBER, DIE DURCH LUFT GEKÜHLT WERDEN

MEC 9000 - 11000 - 13500 BOMBAS DE VACÍO/PRESIÓN DE PALETAS REFRIGERADAS POR AIRE



1 3/8" - ISO 500-1

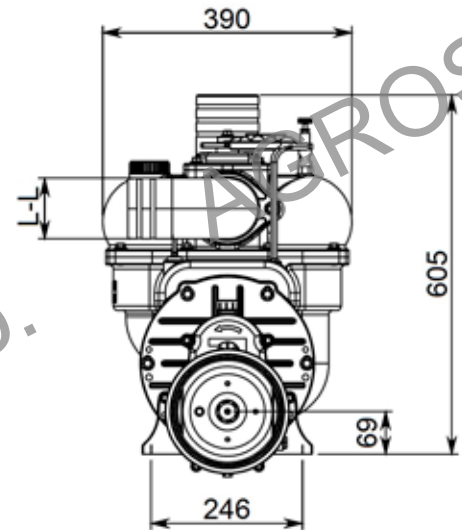
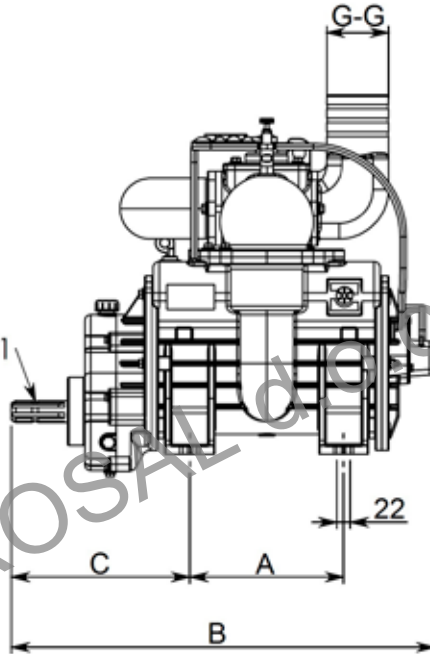

Note: Versione con palette long life, composte quindi di un materiale speciale adatto ad utilizzi intensi. Queste palette offrono un'ottima resistenza all'usura, a stress termici e meccanici e sono indicate per utilizzi più frequenti e per l'aspirazione di liquami più densi. È consigliato per impianti utilizzati da conto terzi e con utilizzi frequenti anche nel corso della stessa giornata. La presa di forza è azionata tramite albero cardanico a 540 rpm. La versione è riconoscibile dalla scatola moltiplicatore posta nella parte anteriore della pompa per vuoto rotativa a palette, dalla targhetta di identificazione. La lubrificazione avviene sia nella fase di aspirazione che nella fase di compressione tramite una pompa ad ingranaggi posta nella parte posteriore e azionata dall'albero rotore. La pompa ad ingranaggi aspira l'olio dal serbatoio e lo invia al rubinetto di dosaggio a regolazione manuale. L'olio eccedente ritorna al serbatoio stesso. Infine è presente un sistema che permette alle flange di scorrere, per evitare rotture in caso d'ingresso di corpi estranei tra rotore e corpo. Per potere beneficiare di questo sistema è importante, prima di avviare la pompa, verificare che il rotore non sia accidentalmente sceso.

Notes: Version with long life blades that are made of a special material suitable for strong uses and for Rotary blades vacuum pump used in agricultural field. These blades offer an excellent resistance to wear and mechanical and thermal stress. These are suitable for more frequent uses and to suck thick sewages. They are recommended for installation with frequent uses even during the same day. The power take-off is actuated through a cardan shaft at 540 r.p.m. This version can be recognised by the gearbox placed at the front of the Rotary blades vacuum pump and by the identification plate. Lubrication runs during both sucking and compression phase thru a gear pump activated by rotary shaft. Gear pump sucks oil from tank and send it to the manual-regulated dosing tap. Exceeding oil goes back in the tank. Finally, there is a system that allows the flange to slide, which prevents breakage if foreign bodies become lodged between the rotor and the pump body. To benefit from this system, it's important that before starting the pump, make sure the rotor has not dropped down accidentally.

Art./Ref.	A mm	B mm	C mm	G mm	L mm	Peso Kg/Weight kg	Note/Note
67913	189	670	340	76-100	76-100	145	MEC 9000
67914	247	740	346	76-80	76-80	160	MEC 11000
67915	247	830	391	76-80	76-80	178	MEC 13500

Art. Ref.	Capacità geometrica Geometrical capacity			Max rpm	Max pressione ata Max abs pressure Bar (PSI)	Aspirazione max Max vacuum % (inHg)	Max aspirazione continua Max continuous vacuum % (inHg)	Potenza all'aspirazione max Power at max vacuum kW (HP)
	m ³ /h	l/min	cfm					
67913	541,8	9030	319	600	2,5 (36)	95 (28,5")	60 (18")	17 (22,8)
67914	668,22	11137	393					21 (28,2)
67915	830,7	13845	489					25 (33,5)

MEC 16000 POMPA PER VUOTO/PRESSIONE A PALETTE RAFFREDDATA A INIEZIONE DI ARIA

MEC 16000 POMPE À VIDE/PRESSION À PALETTES REFROIDIE À INJECTION D'AIR

MEC 16000 AIR INJECTION COOLED - ROTARY VANE VACUUM/PRESSURE PUMP

MEC 16000 PUMPE FÜR VAKUUM/DRUCK MIT SCHIEBER, DIE DURCH LUFTEINLASS GEKÜHLT WERDEN

MEC 16000 BOMBA DE VACÍO/PRESIÓN DE PALETAS REFRIGERADA POR INYECCIÓN DE AIRE

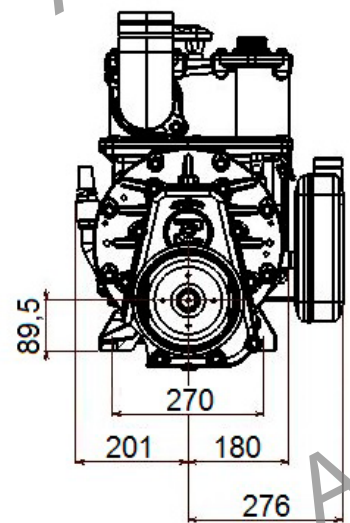
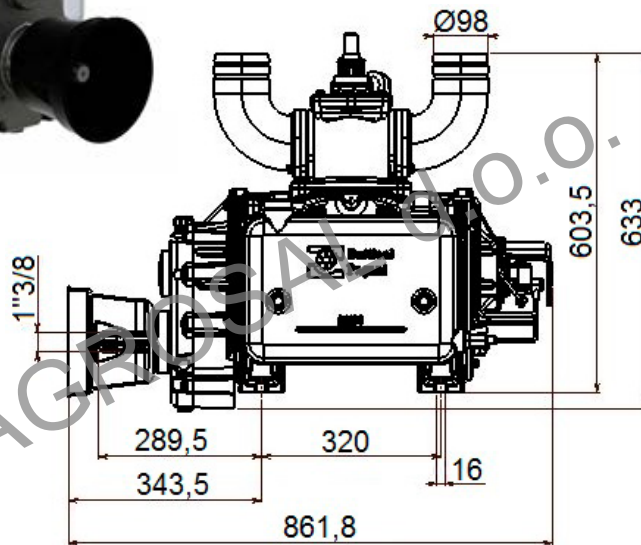

Note: Versione con lubrificazione automatica che avviene nella fase di aspirazione che di compressione mediante l'impiego di una pompa dosatrice a pistoni a portata regolabile posta nella parte posteriore ed azionata dal rotore. L'olio viene iniettato direttamente nella pompa, eliminando la regolazione manuale ed ottenendo un notevole risparmio di olio. Decompressore dotato di palette long life, composte quindi di un materiale speciale adatto ad utilizzi intensi. Queste palette offrono un'ottima resistenza all'usura, a stress termici e meccanici e sono indicate per utilizzi più frequenti e per l'aspirazione di liquami più densi. E' consigliato per impianti utilizzati da conto terzi e con utilizzi frequenti anche nel corso della stessa giornata. La presa di forza è azionata tramite albero cardanico a 540 rpm. La versione è riconoscibile dalla scatola moltiplicatore posta nella parte anteriore della pompa per vuoto rotativa a palette, dalla targhetta d'identificazione. Questo modello è dotato del sistema di sicurezza che permette alle flange di scorrere, per evitare rotture in caso d'ingresso di corpi estranei tra rotore e corpo. Per potere beneficiare di questo sistema è importante, prima di avviare la pompa, verificare che il rotore non sia accidentalmente sceso.

Notes: Versione with automatic lubrication, this system lubrication runs during both sucking and compression phase. It is operated by a shaft-operated adjustable flow dosing pump. Oil is injected directly into pump, removing manual regulation, with a remarkable oil saving. This type of pump have long life blades that are made of a special material suitable for strong uses and for Rotary blades vacuum pump used in agricultural field. These blades offer an excellent resistance to wear and mechanical and thermal stress. These are suitable for more frequent uses and to suck thick sewages. They are recommended for installation with frequent uses even during the same day.

The power take-off is actuated through a cardan shaft at 540 r.p.m. This version can be recognised by the gearbox placed at the front of the Rotary blades vacuum pump and by the identification plate. Finally, there is a system that allows the flange to slide, which prevents breakage if foreign bodies become lodged between the rotor and the pump body. To benefit from this system, it's important that before starting the pump, make sure the rotor has not dropped down accidentally.

Art./Ref.	Peso Kg/Weight Kg	Note/Note
67916	230	BALLAST 16000

Art. Ref.	Capacità geometrica Geometrical capacity			Max rpm	Max pressione ata Max abs pressure Bar (PSI)	Aspirazione max Max vacuum % (inHg)	Max aspirazione continua Max continuous vacuum % (inHg)	Potenza all'aspirazione max Power at max vacuum kW (HP)
	m ³ /h	l/min	cfm					
67916	913	15210	537	600	2,5 (36)	95 (28,5")	70 (21")	33 (44,2)

KIT REVISIONE DECOMPRESSORI BATTIONI PAGANI®

KIT DE RÉVISION PUOR POMPES BATTIONI PAGANI®

REBUILT KIT FOR BATTIONI PAGANI® PUMPS

SET FÜR INSPEKTION FÜR PUMPEN BATTIONI PAGANI®

KIT DE REVISIÓN PARA BOMBAS BATTIONI PAGANI®

Note: Kit composto da palette, guarnizioni e paraoli originali Battioni Pagani®.

Notes: Kit composed of original Battioni Pagani® blades, gaskets and oilseals.

Art./Ref.	Note/Note
67924	modello MEC 2000 standard
67925	modello MEC 3000 standard
67926	modello MEC 4000 standard
67927	modello MEC 5000 standard
67928	modello MEC 6500 standard
67929	modello MEC 8000 standard

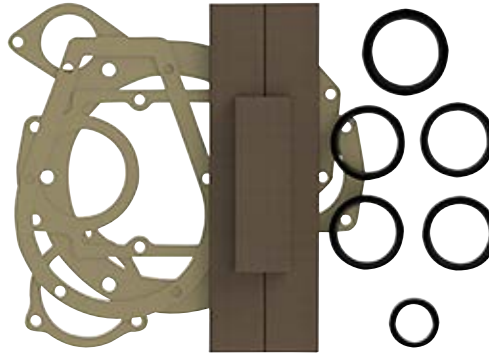

PALETTE RICAMBIO PER DECOMPRESSORI

PALETES DE RECHANGE

PUMP-PARTS

VAKUUMPUMPENERSATZTEILE

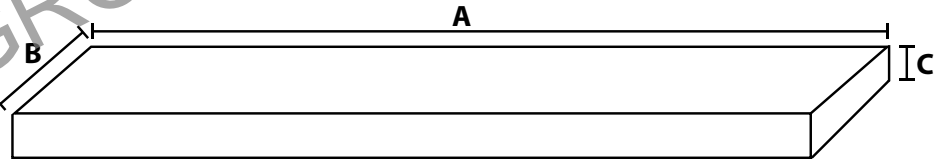
PALETAS DE REPUESTOS PARA DECOMPRESORES



Art./Ref.	A mm	B mm	C mm	Note/Note
04651	180	41	6.5	Battioni e Pagani - Mod. decompres. Decompressor mod. MEC 2000
04652	240	41	6.5	Battioni e Pagani - Mod. decompres. Decompressor mod. MEC 3000
04653	300	41	6.5	Battioni e Pagani - Mod. decompres. Decompressor mod. MEC 4000
04654	300	46.5	6.5	Battioni e Pagani - Mod. decompres. Decompressor mod. MEC 5000
04655	370	46.5	6.5	Battioni e Pagani - Mod. decompres. Decompressor mod. MEC 6500
04656	450	46.5	6.5	Battioni e Pagani - Mod. decompres. Decompressor mod. MEC 8000
11612	400	70	7.5	Battioni e Pagani - Mod. decompres. Decompressor mod. SE-12000
35494	160	57	7.5	Hertell
35485	210	57	7.5	Hertell
39321	214	33	4.4	Hertell
37748	220	45	6	Hertell
37750	240	40	6	Hertell
37751	240	45	6	Hertell
35486	240	64	7.5	Hertell
35487	265	57	7.5	Hertell
39322	300	33	4.4	Hertell
37754	300	40	6	Hertell
35488	300	64	7.5	Hertell
39320	305	42	6	Hertell
35489	309	45	6	Hertell
33652	310	40	6	Hertell
35490	359	45	6	Hertell
37753	360	40	6	Hertell
35496	360	64	7.5	Hertell
35492	425	64	7.5	Hertell
35493	469	45	6	Hertell

SARACINESCA A LEVA

VANNE A LEVIER
LEVER GATE VALVE
HEBELSCHIEBER
TAJADERA CON PALANCA

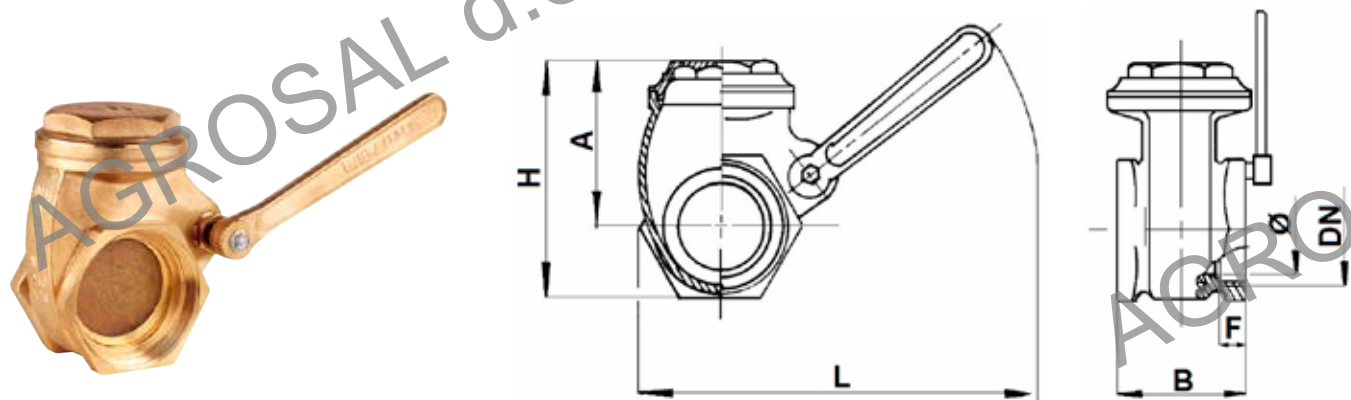

Note: Pressione nominale: 16 bar

Notes: Nominal pressure: 16 bar

Art./Ref.	DN inches/DN inches	Diametro mm/Diameter mm	A mm	B mm	F mm	H mm	L mm
03359	2"	49	54	75	20	115	228
03360	3"	70	117	86	21	165	365
03221	4"	93	150	92	22	212	395

SARACINESCHE A STANTUFFO A UNA GHIERA

VANNE A PISTON
STEMGATE VALVE
KOLBENSCHIEBER
TAJADERA A PISTÓN CON RACOR

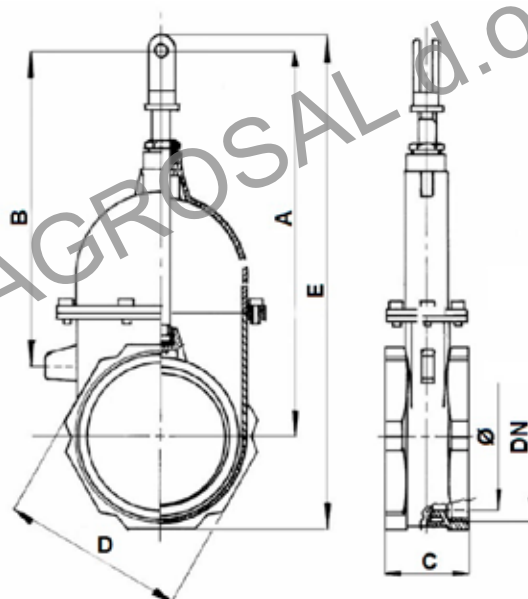

Art./Ref.	DN inches/DN inches	Diametro mm/Diameter mm	Pressione nominale/Nominal pressure	A mm	B mm	C mm	D mm	E mm
03055	4"	91	3	265	220	68	124	320
03056	5"	120	3	340	290	78	152	415
03057	6"	144	2.5	390	320	85	177	480

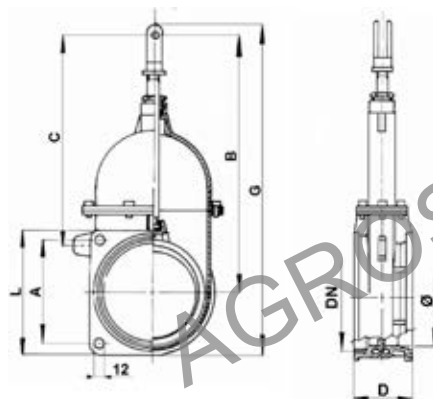
SARACINESCHE A STANTUFFO AD UNA GHIERA E UNA FLANGIA
VANNE A PISTON AVEC BRIDE
STEMGATE VALVE WITH FLANGE
KOLBENSCHIEBER MIT FLANSCH EINSEITIG
TAJADERA A PISTÓN CON RACOR Y COLLAR

Art./Ref.	DN inches/ DN inches	Diametro mm/ Diameter mm	Pressione nominale/ Nominal pressure	A mm	B mm	C mm	D mm	G mm	L mm
03060	5"	120	3	150	350	295	87	455	180
03065	6"	143	2.5	150	390	320	88	485	180

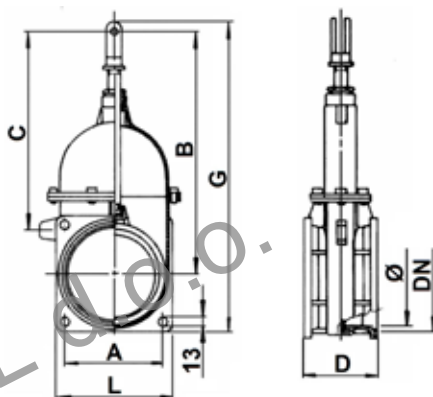
SARACINESCA A STANTUFFO A DOPPIA FLANGIA
VANNE A PISTON AVEC DOUBLE BRIDE
STEM GATE VALVE WITH TWO FLANGES
KOLBENSCHIEBER MIT ZWEI FLANSCHEN
TAJADERA A PISTÓN CON COLLAR DOBLE

Art./Ref.	DN inches/ DN inches	Diametro mm/ Diameter mm	Pressione nominale/ Nominal pressure	A mm	B mm	C mm	D mm	G mm	L mm
03058	4"	91	3	150	290	235	97	385	180
03059	5"	120	3	150	350	295	97	450	180
03066	6"	143	2.5	150	390	320	97	495	180
03069	8"	191	1.5	180	485	385	112	610	230

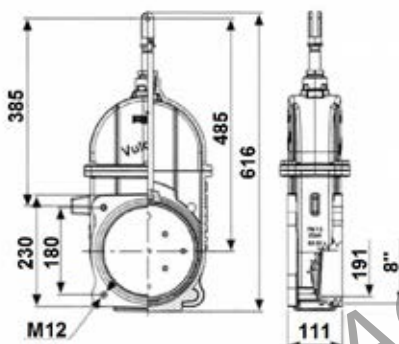
SARACINESCA A STANTUFFO CON CORPO IN GHISA
FLASQUE AVEC CORPE EN FONTE
TWO FLANGE PISTON GATE VALVE WITH CAST IRON BODY
KOLBENSCHIEBER MIT GUSSEISEN-KOERPER
TAJADERA A PISTÓN CON CUERPO EN HIERRO

Art./Ref.	Pressione nominale/Nominal pressure
73452	1,5

SARACINESCA A LAMA - LOCKER

VANNE À GUILLOTINE - LOCKER

KNIFE GATE VALVE - LOCKER

SCHIEBERVENTIL - LOCKER

VÁLVULA DE COMPUERTA DE CUCHILLA - LOCKER

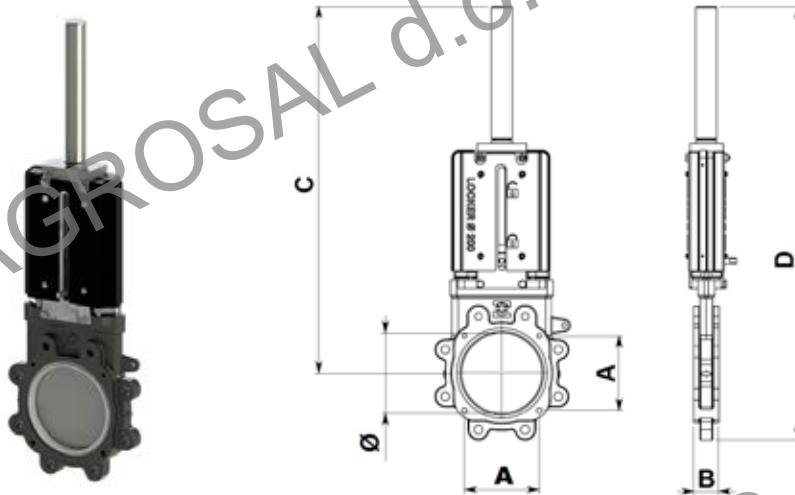

Note: Premicorda in anticorodal anti ossidazione anche a contatto con i liquami. Sistema di tenuta superiore in corda grafitata e anello in gomma. Cuneo (in acciaio INOX AISI 304) riparato da protezione in ABS termoformato. Indicatore apertura/chiusura saracinesca. Verniciatura doppio strato. Corpo in ghisa in fusione unica.

Notes: Anticordal cord holder which avoids oxidatin even with slurry. Top sealing system with graphite ropes and rubber string.

Gate (stainless steel AISI 304) protected by ABS thermoformed. Knife gate valve open/closed indicator.

Double layer painting. Gate body made in one piece casting.

Art./Ref.	Diametro mm/Diameter mm	A mm	B mm	C mm	D mm	Pressione nominale/Nominal pressure	Peso Kg/Weight Kg
67917	100	150	60	610	715	10 bar	17
67918	150	150	60	800	930	10 bar	20
67919	200	180	60	885	1045	10 bar	28
67920	250	-	62	1100	1300	8 bar	46
67921	300	-	62	1200	1430	7 bar	55

CILINDRO OLEODINAMICO DOPPIO EFFETTO PER L'APERTURA/CHIUSURA DELLE SARACINESCHE

VERIN HYDRAULIQUE D.E POUR VANNES

HYDRAULIC CYLINDER FOR VALVES

HYDRAULISCHE-ZYLINDER FÜR SCHIEBE

CILINDRO HIDRÁULICO DOBLE EFECTO PARA ABRIR/CIERRAR TAJADERAS

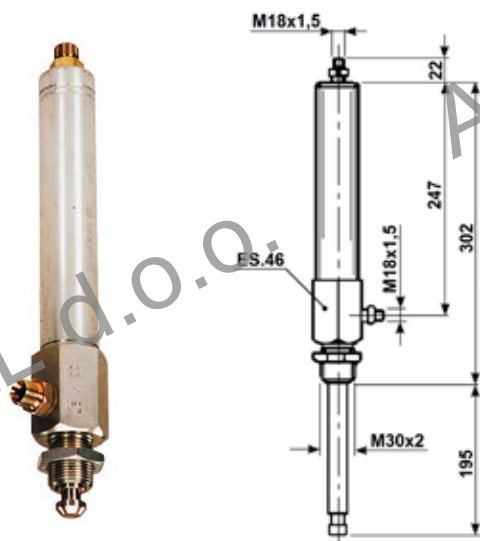

Art./Ref.	Note/Note
06655	per saracinesche 4"- 5"- 6"

CILINDRO OLEODINAMICO SEMPLICE EFFETTO RITORNO CON MOLLA A GAS

VERIN PNEUMATIQUE S.E RETOUR PAR RESSORT A GAZ
 HYDRAULIC CYLINDER SINGLE ACTING
 HYDRAULIK - ZYLINDER E.W FÜR SCHIEBER
 CILINDRO HIDRÁULICO EFECTO SIMPLE CON MUELLE GAS

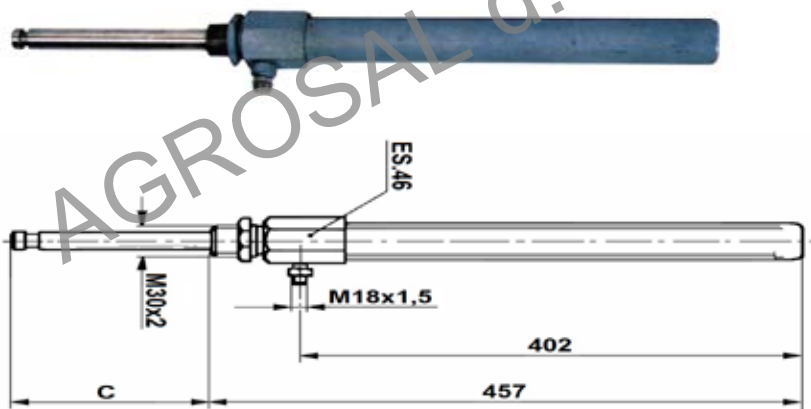

Note: Modello Metaltecnica

Notes: Metaltecnica model

Art./Ref.	Cmm	Note/Note
15817	133	per saracinesche 4"
15818	157	per saracinesche 5"
15819	187	per saracinesche 6"

PISTONI SEMPLICE EFFETTO AD OLIO

VERINS SIMPLE EFFECT A HUILE
 SINGLE-ACTING OIL JACKS
 EINFACHWIRKENDE ZYLINDER
 PISTONES SIMPLE EFECTO CON ACEITE



Note: Modello RIV

Notes: RIV model

Art./Ref.	Note/Note
39889	per saracinesche 4"
39890	per saracinesche 5"
39891	per saracinesche 6"

RUBINETTO A 3 VIE FLANGIATO

ROBINET A 3 VOIES AVEC FLASQUE
THREE-WAY FLANGED PLUG COCK
3-WEGE-HAHN MIT FLANSCH
GRIFO CON ARANDELA 3 VIAS

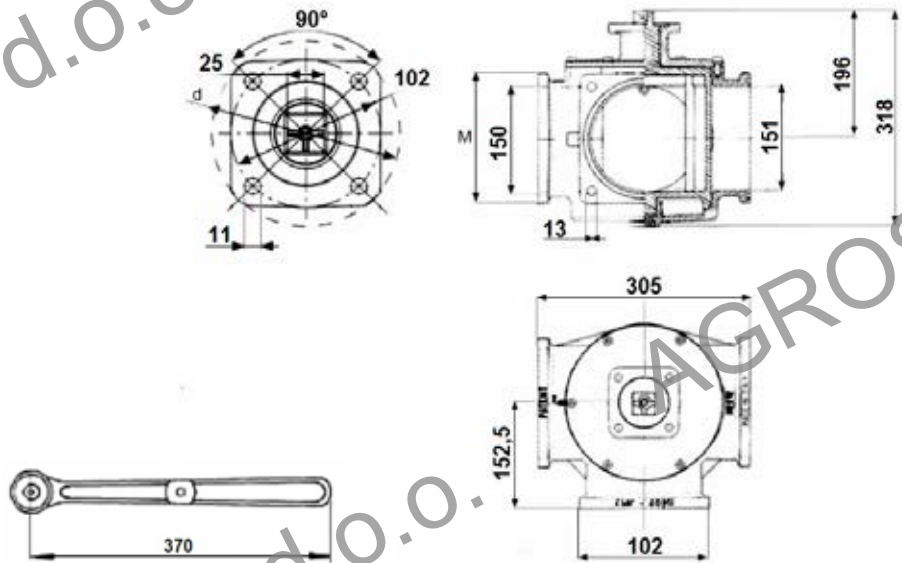

Note: Il problema del "grippaggio", sempre presente nei tradizionali rubinetti a maschio conici, è stato risolto definitivamente grazie alla geometria cilindrica dell'otturatore. Con l'ausilio di una speciale guarnizione di tenuta, antiusura ed inattaccabile da agenti chimici, questo rubinetto è in grado di garantire una tenuta perfetta per qualsiasi applicazione (carribotte, impianti zootecnici, autospurghi, ecc), caratteristica pressochè impossibile da trovare nei tradizionali rubinetti a maschio nei quali la tenuta viene realizzata tramite il contatto di due superfici metalliche. Grazie a queste soluzioni, si manovra manualmente con estrema facilità. La parte superiore ha comunque una flangetta d'attacco che permette all'occorrenza di applicare un attuatore oleodinamico o pneumatico. La pressione massima di utilizzo si intende a temperatura ambiente di circa 23°C ed è di 4 bar.

Notes: The problem of "seizing" always present in the traditional tapered plug cocks has been definitively solved thanks to the cylindrical shape of the plug. Thanks to a special wear resistant and chemical agent-proof gasket, this plug clock can guarantee a perfect tightness for any application (vacuum tankers, zootechnical plants, sewer cleaning tanks, etc.). It is almost impossible to find this feature in the traditional plug cocks in which the tightness is obtained through the contact between two metal surfaces. Thanks to these exclusive solutions it can be operated by hand very easily. The top part is equipped for the automation with a flanged connection, where, in case of need, it is possible to mount a hydraulic or pneumatic actuator. The max working pressure (4 bar) means at a temperature of about 23°C.

Art./Ref.	Pos.
73453	1
73454	2

RUBINETTO 3 - 4 VIE CON LEVA

ROBINET 3 - 4 VOIES AVEC LEVIER
3 - 4 WAYS VALVE WITH LEVER
HAHN 3 - 4 ABZWEIGUNGEN UND HEBEL
LLAVE 3 - 4 VIAS CON PALANCA

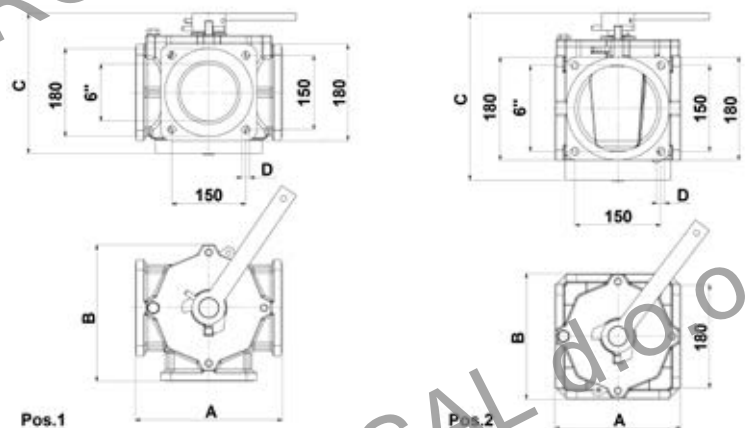
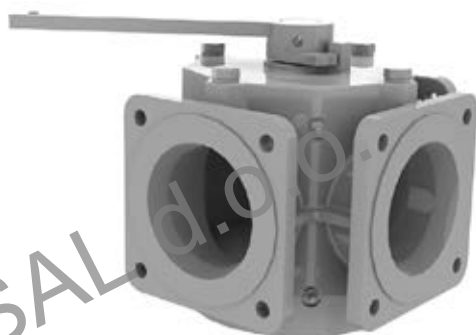

Note: Pressione d'esercizio: 6 bar. Temperatura: da -15°C a +80°C. Ingrassaggio agevole.

Notes: Working pressure: 6 bar. Temperature: from -15°C to 80°C Easy greasing.

Art./Ref.	Pos.	Diametro mm/Diameter mm	A mm	B mm	C mm	D mm	Peso Kg/Weight Kg	Note/Note
67938	1	152	305	303	265	13	42,8	6" - 3 vie/6" - 3 ways
67939	2	112	220	220	283	M12	36	6" - 4 vie/6" - 4 ways

GETTO GIREVOLE IDRAULICO

JET PIVOTANT HYDRAULIQUE
 HYDRAULIC SWIVEL CAST IRON PIPE
 HYDRAULISCH AUSRICHTBARE DÜSE
 CAÑON GIRO HIDRÁULICO

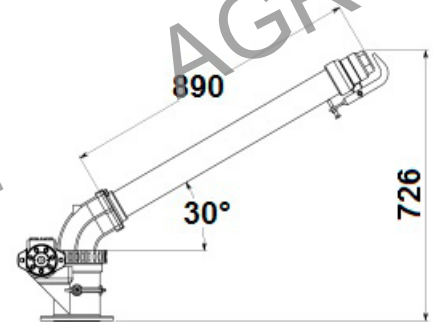
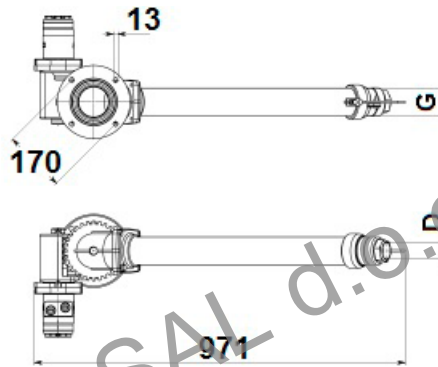

- Note:** - Ghisa sferoidale ad alta resistenza
 - Ingrassaggio agevole
 - Rotazione di 360°
 - Frangigetto di serie
 - tubo zincato

- Notes:** - High resistance spheroidal cast-iron
 - Easy greasing
 - Rotation of 360°
 - Break - sewage
 - Galvanized pipe

Art./Ref.	Diametro mm/Diameter mm	D mm	G mm	Peso Kg/Weight Kg
67934	3"	25 - 34	2"1/2	25,5
67936	4"	34	3"	28,5

GETTO GIREVOLE REGOLABILE IN ALTEZZA

JET PIVOTANT RÉGLABLE EN HAUTEUR
 HYDRAULIC SWIVEL ADJUSTABLE CAST IRON PIPE
 HÖHE VERSTELLBARE, AUSRICHTBARE DÜSE
 CAÑON GIRO REGULABLE EN ALTURA

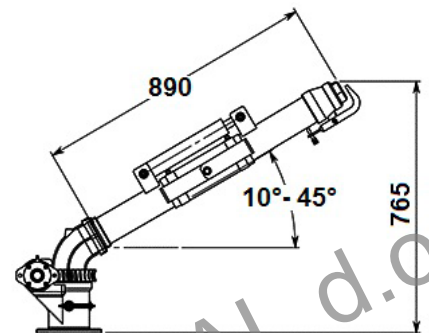
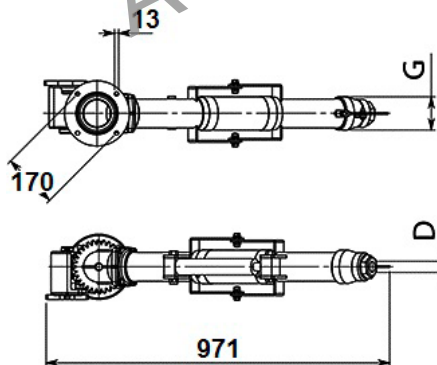

- Note:** - Ghisa sferoidale ad alta resistenza
 - Ingrassaggio agevole
 - Rotazione di 360°
 - Frangigetto di serie
 - Tubo zincato

- Notes:** - High resistance spheroidal cast-iron
 - Easy greasing
 - Rotation of 360°
 - Break - sewage
 - Galvanized pipe

Art./Ref.	Diametro mm/Diameter mm	D mm	G mm	Peso Kg/Weight Kg
67935	3"	25 - 34	2"1/2	28
67937	4"	34	3"	31

GIUNTO GIREVOLE MOTORIZZATO - REVOBLOCK

COLLIER ORIENTABLE MOTORISÉ - REVOBLOCK

HYDRAULIC SWIVEL JOINT - REVOBLOCK

MOTORBETRIEBENE DREHVERBINDUNG - REVOBLOCK

JUNTA ROTATIVA MOTORIZADA - REVOBLOCK



- Note:** Pressione = 6 bar
 Temperatura da -15°C a 80°C
 - Ghisa sferoidale ad alta resistenza
 - Tenuta garantita da 2 OR
 - Ingrassaggio agevole
 - Rotazione di 360°
 - Filtratura con modulo ad alta resistenza ad usura
 - Impianto auto frenante in caso di mancanza di pressione
 - Montaggio come elemento strutturale sia con asse orizzontale che con asse verticale
 - sottoposto ad analisi dei rischi fatta sulla linea guida EN ISO 14121-1:2007

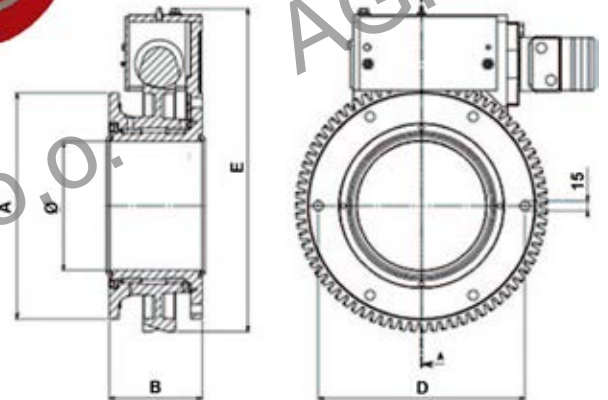

- Notes:** Pressure = 6 bar
 Temperature from -15°C to 80°C
 - High resistance spheroidal cast-iron
 - Sealing secured by 2 O-rings
 - Easy greasing
 - Rotation of 360°
 - Thread with high wear resistance module
 - Brake system in case of lack of pressure
 - Assembly as structural element, both with horizontal and vertical axis
 - subject to risks analysis is on line EN ISO 14121-1:2007

Art./Ref.	Diametro mm/Diameter mm	A mm	B mm	D mm	E mm	Peso Kg/Weight Kg	Note/Note
67922	200	350	144	320	500	58	6 buchi / 75 denti
67923	250	410	154	370	511	72	8 buchi / 75 denti

GIUNTO GIREVOLE

COLLIER ORIENTABLE

SWIVEL JOINT

DREHVERBINDUNG

NUDOS GIRABLES



- Note:** Pressione = 6 bar
 Temperatura da -15°C a 80°C
 - Ghisa sferoidale ad alta resistenza
 - Tenuta garantita da 3 OR
 - Ingrassaggio agevole
 - Rotazione di 360°

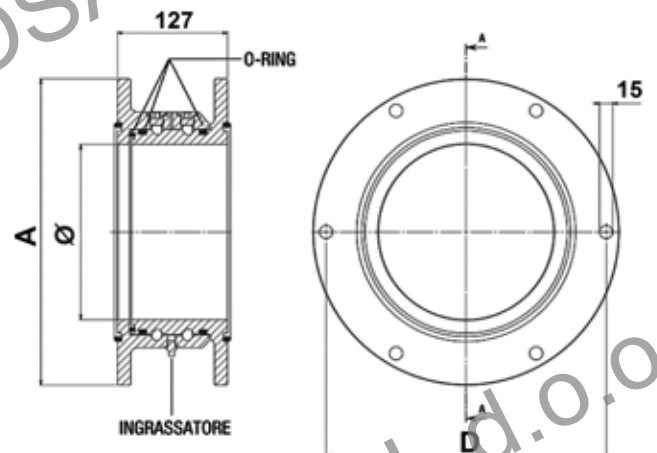

- Notes:** Pressure = 6 bar
 Temperature from -15°C to 80°C
 - High resistance spheroidal cast-iron
 - Sealing secured by 3 O-rings
 - Easy greasing
 - Rotation of 360°

Art./Ref.	Diametro mm/Diameter mm	A mm	D mm	Peso Kg/Weight Kg	Note/Note
67930	100	250	220	16,4	6 buchi
67931	150	290	260	21,5	6 buchi
67932	200	350	320	28,2	6 buchi
67933	250	410	320	37	8 buchi

SARACINESCA IN BRONZO A CHIUSURA RAPIDA F-F

VANNE EN BRONZE FERMETURE RAPIDE F-F
 QUICK OPENING BRONZE GATE VALVE F-F
 MUFFENSCHIEBER BRONZE SCHLIESSENDE SCHNELL
 VÁLVULA EN BRONCE CON CIERRE RÁPIDO F-F



Note: Corpo in bronzo, tappo e disco in ottone; asta, ferma asta e premistoppa in ottone, leva di comando in alluminio plastificato con resina epossidica rossa.

Le pressioni nominali indicate, sono riferite ad una pressione di esercizio di 80°C

Notes: Bronze body, brass cap and wedge; brass stem, stop ring and gland, aluminium lever with red palstic coat. Nominal pressures related to working pressures at 80°C max

Art./Ref.	Filettatura/Thread	Pressione nominale/Nominal pressure
85914	1" 1/2	10
85915	2"	10
85916	2" 1/2	6
85917	3"	6
85918	4"	6

SARACINESCA IN OTTONE F-F, PASSAGGIO TOTALE

VANNE EN LAITON - PASSAGE TOTAL
 LEVER GATE VALVE
 MUFFENSCHIEBER MESSING
 COMPUESTAS CON PALANCA



Note: Le pressioni nominali - PN - indicate per ogni articolo e dimensione sono riferite ad una temperatura di 80° C

Notes: Rated temperate stated for each item and dimension correspond to a 80° C pressure.

Art./Ref.	Filettatura/Thread	Pressione nominale/Nominal pressure
85919	1/2"	16
19707	3/4"	16
85920	1"	16
19709	1" 1/4	16
19710	1" 1/2	16
85921	2"	16
19712	2" 1/2	16
19713	3"	16
19714	4"	16
85922	5"	10
85923	6"	10

VALVOLA A SFERA F-F, PASSAGGIO TOTALE CON MANIGLIA

SOUPAPE A BOULET F-F, AVEC LEVIER
 FULLWAY BALL VALVE F-F, WITH LEVER
 KUGELVENTIL F-F, DURCHGANG MIT GRIFF
 VÁLVULA DE BOLA F - F - CON MANGO



Art./Ref.	Filettatura/Thread	Pressione nominale/Nominal pressure
03329	1/4"	20
03333	3/8"	20
03334	1/2"	20
03335	3/4"	20
03336	1"	20
03337	1" 1/4	16
03338	1" 1/2	16
03339	2"	16
85924	2" 1/2	10
85925	3"	10
85926	4"	10

VALVOLE A SFERA M-F, PASSAGGIO TOTALE CON MANIGLIA

SOUPAPE A BOULET M-F, AVEC LEVIER
 FULLWAY BALL VALVE M-F, WITH LEVER
 KUGELVENTIL M-F, DURCHGANG MIT GRIFF
 VÁLVULA DE BOLA M - F - CON MANGO

Note: Pressione nominale: 25 bar

Notes: Nominal pressure: 25 bar

Art./Ref.	Filettatura/Thread
03409	1/2"
03407	3/4"
03408	1"

RUBINETTO PORTAGOMMA A SFERA CURVO CON MANIGLIA

ROBINET PORTE-GOMME A BOULET COUBRE AVEC LEVIER
 CURVED BALL TAP WITH LEVER AND HOSE RING
 KUGELAUFLAUFVENTIL GEBOGEN FÜR SCHLAUCHSTÜCK MIT GRIFF
 GRIFO PORTAGOMA CURVO CON MANGO



Art./Ref.	Filettatura/Thread	Note/Note
03327	3/8"	Portagomma 3/8" - Tipo Standard
03340	1/2"	Portagomma 1/2" - Tipo Standard
03328	3/4"	Portagomma 3/4" - Tipo Standard
03350	1"	Portagomma 1" - Tipo Standard
18784	1/2"	Portagomma 1/2" - Tipo Compact

VALVOLA A SFERA F-F CON MANIGLIA A FARFALLA

SOUPAPE A BOULET F-F, AVEC LEVIER
 FULLWAY BALL VALVE F-F, WITH LEVER
 KUGELVENTIL F-F, DURCHGANG MIT GRIFF
 VÁLVULA DE BOLA F - F - CON MANGO

Note: Pressione nominale: 10 bar La pressione nominale indicata è riferita ad una temperatura di 80°C
Notes: Nominal pressure: 10 bar Rated pressure stated correspond to a 80°C temperature

Art./Ref.	Filettatura/Thread
18785	1/4"
18786	3/8"
18787	1/2"



VALVOLA A SFERA M-F, CON MANIGLIA A FARFALLA

SOUPAPE A BOULET M-F, AVEC LEVIER
 FULLWAY BALL VALVE M-F, WITH LEVER
 KUGELVENTIL M-F, DURCHGANG MIT GRIFF
 VÁLVULA DE BOLA M - F - CON MANGO

Note: Pressione nominale: 10 bar. La pressione indicata è riferita ad una temperatura di 80 °C
Notes: Nominal pressure: 10 bar Rated pressure stated correspond to a 80°C temperature

Art./Ref.	Filettatura/Thread
18788	1/4"
18789	3/8"
19691	1/2"



VALVOLE A SIFONE

SIPHONS
 FLOAT VALVE
 SIPHON ABSCHIEDER
 VÁLVULA DE SIFÓN

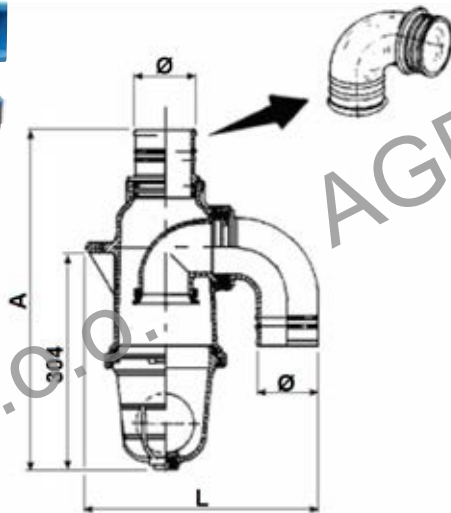

Art./Ref.	Diametro mm/Diameter mm	Note/Note	A mm	L mm
12481	50	Dritto	450	276
03300	60	Dritto	451	284
03301	60	Curvo	485	284
03303	80	Dritto	455	307
03305	80	Curvo	500	307

SFERE LEGGERE (FALLEGGIANTE)

SPHERE LEGERE
 LIGHT SPHERE
 KUGEL FÜR ABSCHIEDER
 BOLAS DE FLOTACIÓN



Art./Ref.	Diametro mm/Diameter mm
01404	60
03344	70
01405	80
03345	100

COPPE IN POLICARBONATO A RICAMBIO

BOL POUR SIPHON
 CUP
 HAUBE
 COPAS DE REPUESTO



Art./Ref.	Pos.	Note/Note
03299	1	da agganciare, applicabile Ø: 50 - 60 - 75 - 80
03302	2	da agganciare, applicabile Ø: 50 - 60 - 75 - 80
78516	3	da avvitare, applicabile Ø: 50 - 60 - 80

VALVOLA CLAPET IN OTTONE

SOUPAPE EN LAITON
 BRASS SWING CHECK VALVE
 MESSINGE BODENVENTIL
 VÁLVULA EN LATON

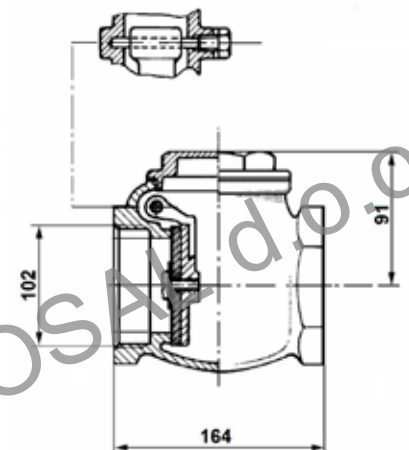

Note: Sede metallica
Notes: Metal disk

Art./Ref.
17746

MANOVUOTOMETRO

MANUVACUUMETRE
MANUVACCUMMETTER
MANUVAKUUMETER
VACUÓMETRO



Art./Ref.	Diametro mm/Diameter mm	Filettatura/Thread
03347	60	1/4"
03210	80	3/8"
19318	100	1/2"

SPIA LIVELLO CON GUARNIZIONE

VOYANT NIVEAU
LEVEL INDICATOR WITH GASKET
SCHAUGLAS MIS. DICHTUNG
INDICADOR NIVEL CON GUARNICIÓN



Art./Ref.	Filettatura/Thread
00471	2"
03385	3"

GHIERA FILETTATA PER SPIA DI LIVELLO

FRETTE POUR VOYANT
THREADED RING
GEWINDESTUTZ
RACOR ROSCADO PARA INDICADOR DE NIVEL



Art./Ref.	Filettatura/Thread
00472	2"
03386	3"

VALVOLA DI TROPPO PIENO A 2 SFERE

SOUPAPE DE TROP-PLEIN A 2 BOULE
TWO BOWLS OVERFLOW VALVE
ÜBERLAUFVENTIL MIT ZWEI KUGEL
VÁLVULA DE DEMASIADO LLENO CON 2 BOLAS

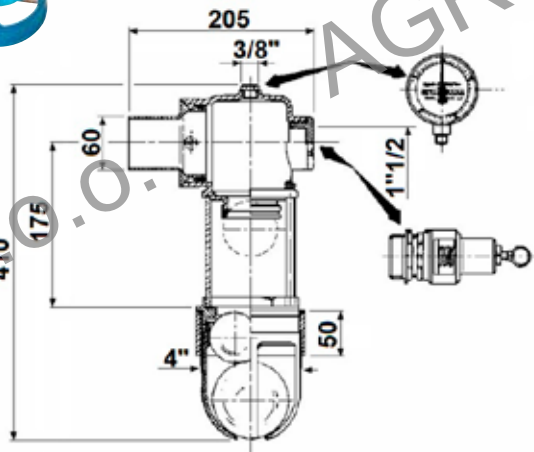

Art./Ref.
03216

VALVOLE DI SICUREZZA

CLAPET DE SECURITÉ
SECURITY VALVES
SICHERHEITSVENTIL
VÁLVULAS DE SEGURIDAD

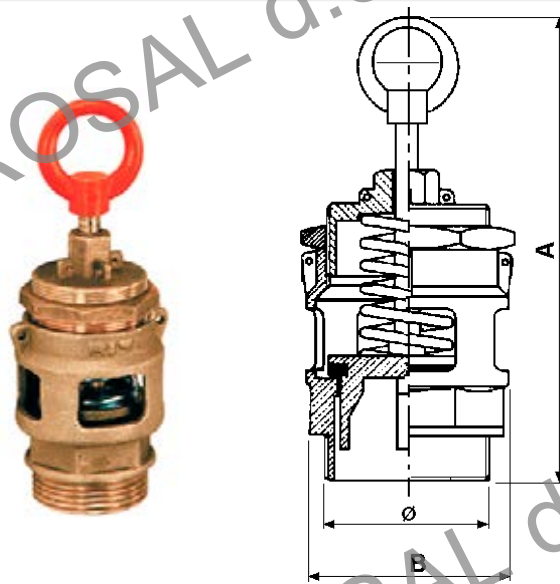

Art./Ref.	A mm	B mm	Diametro mm/ Diameter mm	Brand	Applicazione/ Application
03212	180	60	1" 1/4	-	-
03211	180	65	1" 1/2	A.M.A.	03216
03348	183	80	2"	-	-

VALVOLE DI SICUREZZA CON PORTAGOMMA

CLAPET DE SECURITÉ AVEC RACCORD POUR TUYAU
 SECURITY VALVES WITH HOSE CONNECTION
 SICHERHEITSVENTIL MIT SCHLAUCHANSCHLUSS
 VÁLVULAS DE SEGURIDAD CON PORTAGOMA

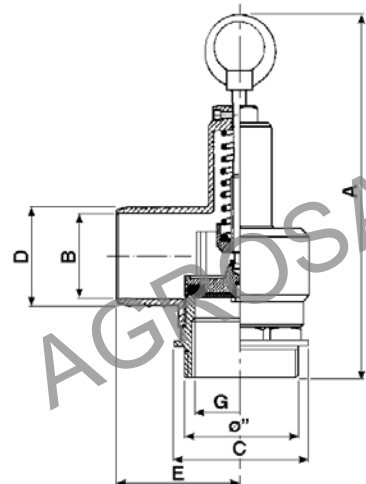

Art./Ref.	A mm	B mm	C mm	D mm	E mm	G mm	Diametro mm/Diameter mm	Brand	Applicazione/Application
03213	180	32	58	40	54	32	1" 1/4		
03214	180	38	60	46	62	40	1" 1/2	A.M.A.	03216
03218	183	42	77	50	72	49	2"		

VALVOLA DI DEPRESSIONE

SOUPAPE DE DEPRESSION
 DEPRESSION VALVE
 UNTERDRUCK VENTIL
 VÁLVULA DE DIMINUCIÓN

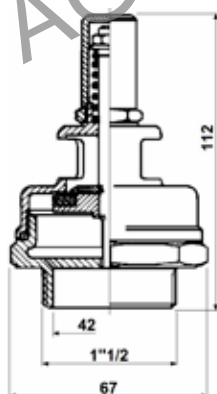

Art./Ref.
03209

OLIATORE CONTAGOCCE DOPPIO

ROBINET DOUBLE GOUTTE A GOUTTE
 DOUBLE DROP OIL REGULETOR
 TROPFÖLER ZWEIFACH
 ACEITERA CUENTAGOTAS DOBLE

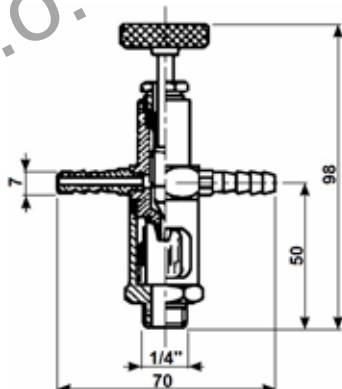

Art./Ref.
03346