

AGROSAL d.o.o.

B BERTOLINI

405, 406, 408



AGROSAL d.o.o.

*Gregorčičeva ulica 38, 5270 Ajdovščina
telefon: 05 368 90 96, fax: 05 368 90 97
e-mail: info@agrosal.si, www.agrosal.si*



**CATALOGO GENERALE RICAMBI
SPARE PARTS MASTER CATALOGUE
CATALOGUE GENERAL PIECES DE RECHANGE
CATALOGO GENERAL PIEZAS DE REPUESTO
ERSATZTEILE ALLGEMEIN KATALOG
REV 07-06**

BERTOLINI
SPA

KAZALO - INDEX



Motokultivator - Motor Cultivator	405
Motokultivator - Motor Cultivator	406
Motokultivator - Motor Cultivator	408

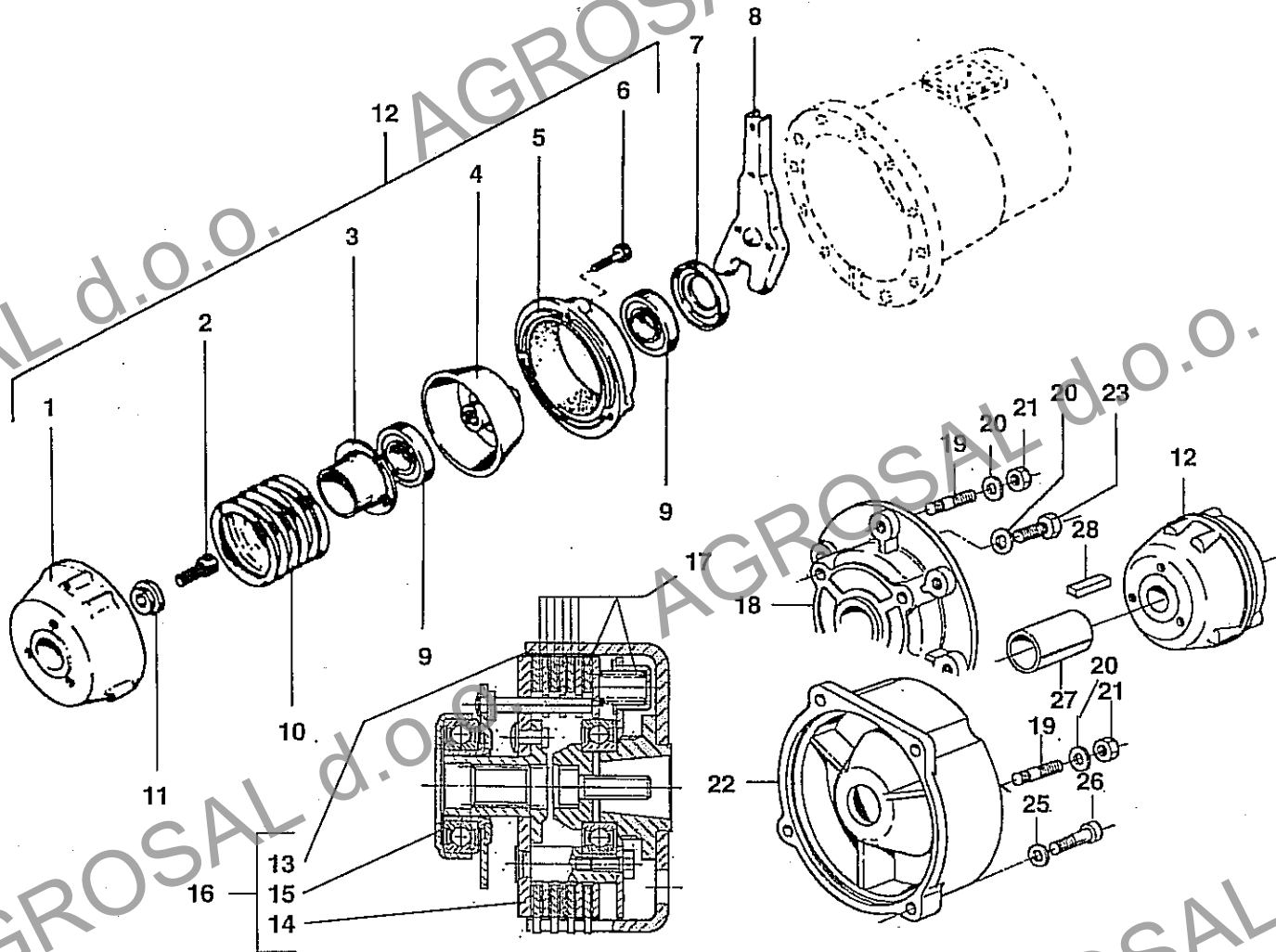

No. pezzo No. pièce No. pièce No. Bild No. pieza	No. di ordinazione Part No. No. de commande Bestell. - Nr. No. de pedido	No. pezzo No. pièce No. pièce No. Bild No. pieza	No. di ordinazione Part No. No. de commande Bestell. - Nr. No. de pedido	No. pezzo No. pièce No. pièce No. Bild No. pieza	No. di ordinazione Part No. No. de commande Bestell. - Nr. No. de pedido
1	F75.0001 ▼	17	F109.0006		
-	F105.0029 ○	18	F105.0027		
2	N6.2680.00 ▼	19	N3.8125.00		
-	N6.2439.50 ○	20	N4.3654.00		
3	F105.0005	21	N1.4574.00		
4	F105.0006	22	F105.0031		
5	F75.0004	23	N6.2439.80		
6	N6.2348.00	25	N4.3764.00		
7	F75.0014	26	N6.3097.90		
8	F75.0011	27	F105.0028 ○		
9	N1.2632.01 6004.2RS	28	N.6434.10 ○		
10	N3.1381.86				
11	F105.0003				
12	P443 ▼				
-	P1008 ○				
13	F109.0003				
14	F109.0004				
15	F109.0005				
16	F109.0002				

Segnalazioni di validità
Usage code
Signalisations de validité
Gültigkeitsvermerk
Indicaciones de validez

CA 240 ○ HONDA GX 160
▼ A 220
MICRO 51

FICHES
[]

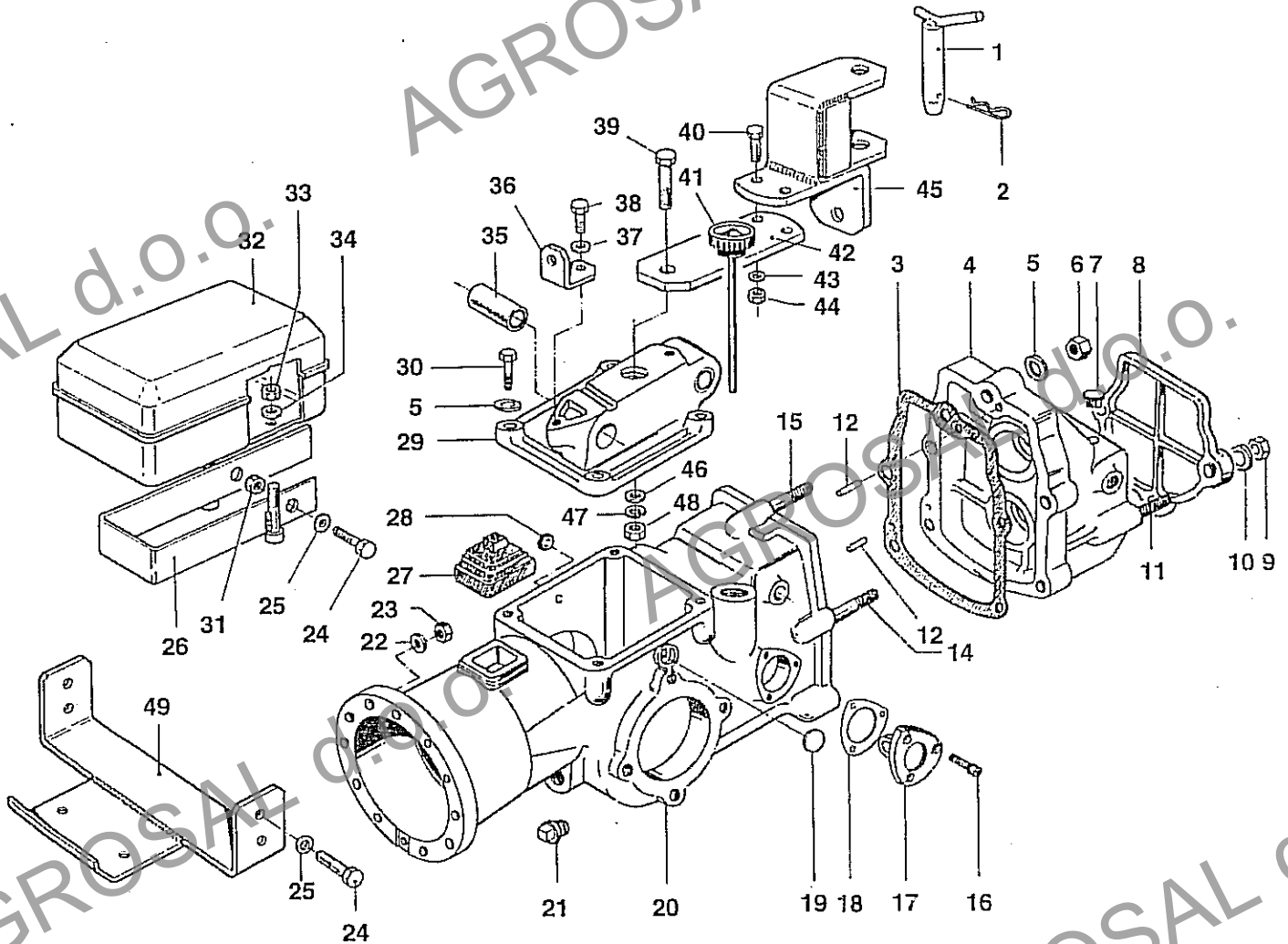

No. pezzo No. pièce No. pièce No. Bild No. pieza	No. di ordinazione Part No. No. de commande Bestell.-Nr. No. de pedido	No. pezzo No. pièce No. pièce No. Bild No. pieza	No. di ordinazione Part No. No. de commande Bestell.-Nr. No. de pedido	No. pezzo No. pièce No. pièce No. Bild No. pieza	No. di ordinazione Part No. No. de commande Bestell.-Nr. No. de pedido
1	F75.1647	18	F105.0827	37	N4.3667.00
2	N5.1488.00	19	N5.2613.00	38	N6.2621.00
3	F105.0822	20	F105.0801	39	N6.4066.00
4	F105.0834	21	N5.2540.00	40	N6.3254.00
5	N4.3763.00	22	N4.3654.00	41	N5.3506.00
6	N1.4620.00	23	N1.4574.00	42	F118.2103
7	F75.0835	24	N6.2488.00	43	N4.3799.00
8	F105.0833	25	N4.3649.00	44	N1.4632.00
9	N1.4705.00	26	F118.2104	45	F118.4701
10	N4.3877.00	27	F75.1646	46	N4.3844.00
11	N3.8615.00	28	N5.2562.00	47	N4.3905.00
12	N5.1264.00	29	F107.0801	48	N1.4695.00
-	N5.1243.00	30	N6.3275.00	49	F105.2122
14	N3.8399.00	31	N1.4574.00	50	F118.2106
-	N3.8363.00	32	F118.2105	51	F118.2107
-	N3.8412.00	33	N1.4574.00		
15	N3.8420.00	34	N4.3694.00		
16	N6.2108.00	35	N4.9247.00		
17	F118.0808	36	F107.1617		

Segnalazioni di validità
Usage code
Signalisations de validité
Gültigkeitsvermerk
Indicaciones de validez

△ Targhetta frontale su serbatoio "BERTOLINI" (405)
▲ Targhetta laterale su serbatoio "BERTOLINI"
□ → 1735 ▣ 1736

FICHES
[]

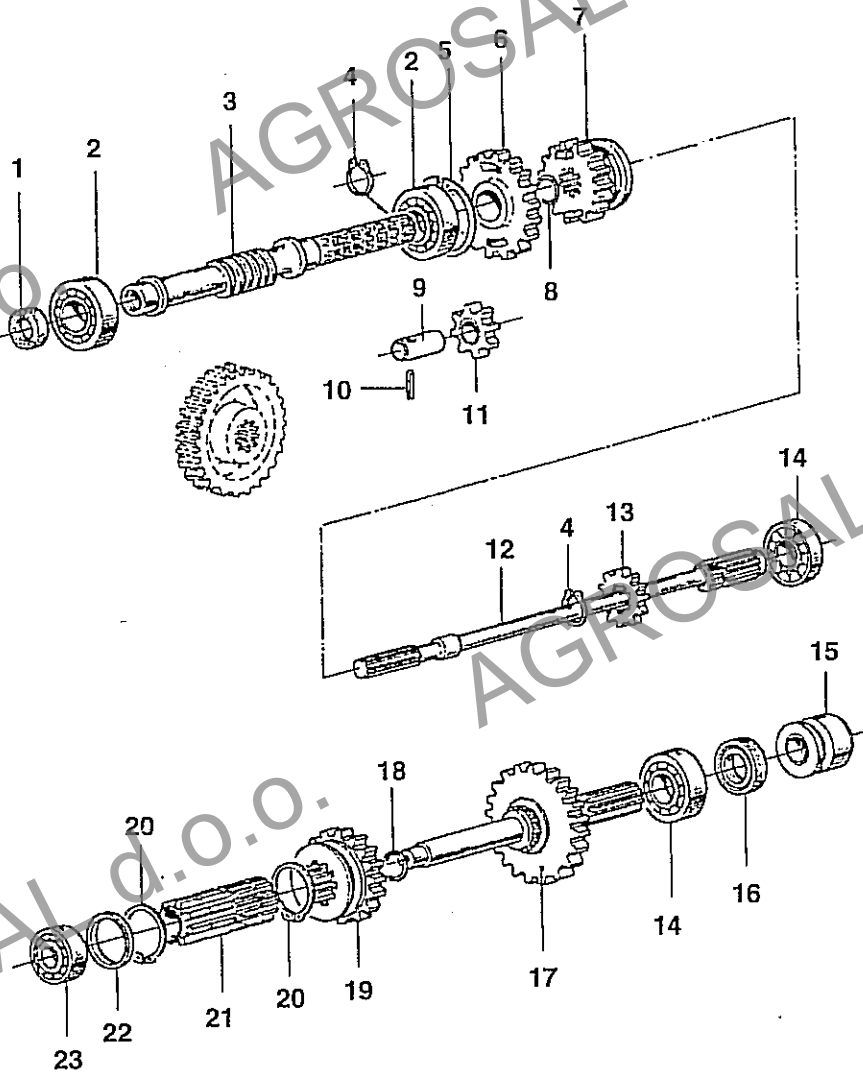

No. pezzo No. pièce No. Bild No. pieza	No. di ordinazione Part No. No. de commande Bestell.-Nr. No. de pedido	No. pezzo No. pièce No. Bild No. pieza	No. di ordinazione Part No. No. de commande Bestell.-Nr. No. de pedido	No. pezzo No. pièce No. Bild No. pieza	No. di ordinazione Part No. No. de commande Bestell.-Nr. No. de pedido
1	N.2047.50	20	N.1241.00 A30		
2	N1.2707.00 b205	21	F118.0812		
3	F118.0807	22	F118.0811		
4	N.1168.00 A23	23	N1.2515.00		
5	N.1368.00 H52				
6	F105.0813				
7	F105.0812				
8	N.0046.50				
9	F105.0826				
10	N5.1014.50				
11	F105.0811				
12	F118.0800				
13	F118.0801				
14	N1.2637.00 b204				
15	F105.0839				
16	N.2073.00 20x35x7				
17	F118.0804				
18	N.1225.00				
19	F118.0806				

Segnalazioni di validità
Usage code
Signalisations de validité
Gültigkeitsvermerk
Indicaciones de validez

FICHES



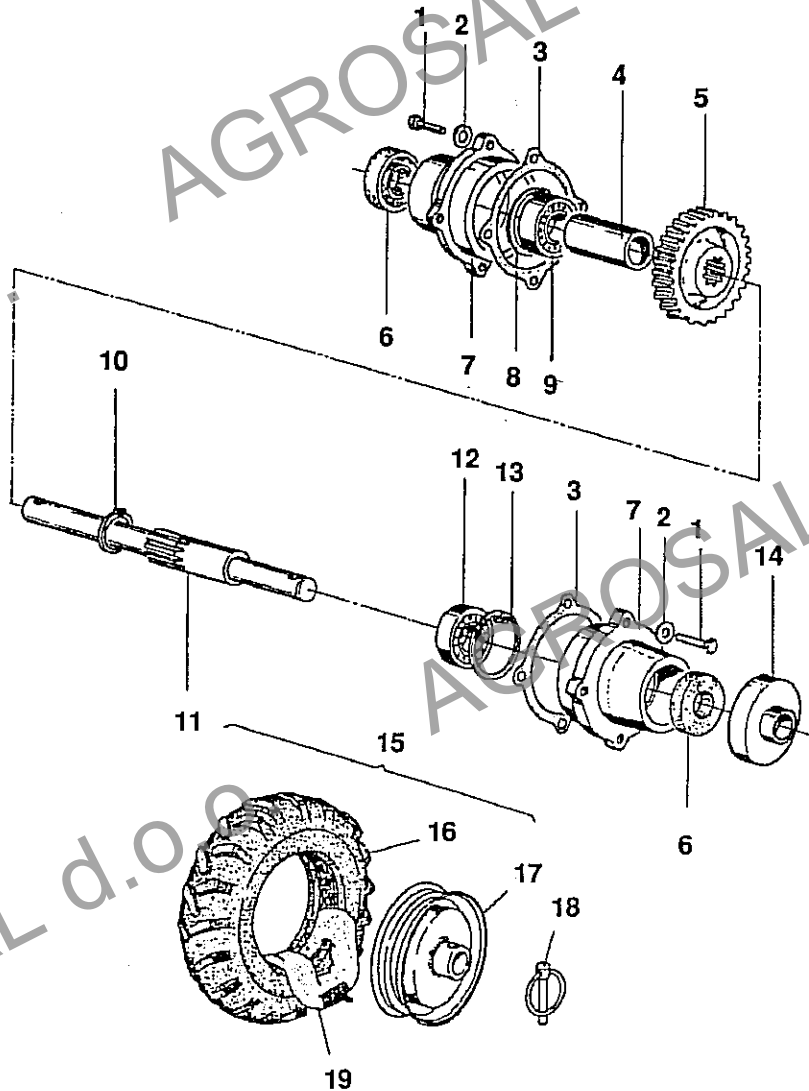

No. pezzo No. pièce No. pièce No. Bild No. pieza	No. di ordinazione Part No. No. de commande Bestell.-Nr. No. de pedido	No. pezzo No. pièce No. pièce No. Bild No. pieza	No. di ordinazione Part No. No. de commande Bestell.-Nr. No. de pedido	No. pezzo No. pièce No. pièce No. Bild No. pieza	No. di ordinazione Part No. No. de commande Bestell.-Nr. No. de pedido
1	N6.2669.00	18	N5.1407.70		
2	N4.3649.00	19	N4.8811.20 ●		
3	F105.0202	-	N4.8811.00 ○		
4	F105.0205				
5	F109.0217				
6	N.2100.50 OK 25X52x7				
7	F105.0201				
8	N.1368.00 H52				
9	N1.2707.00 6205				
10	N.1241.50				
11	F118.0201				
12	N1.2707.00 6205				
13	N.1368.00 H52				
14	F118.0202				
15	P1078 ▼				
-	P1071 ▲				
16	N4.8508.00 ▼				
-	N4.8516.00 ▲				
17	N4.9008.40				

Segnalazioni di validità
Usage code
Signalisations de validité
Gültigkeitsvermerk
Indicaciones de validez

▼ 3.50-8" ○ CONTINENTAL
▲ 4.00-8" ● CEAT

FICHES



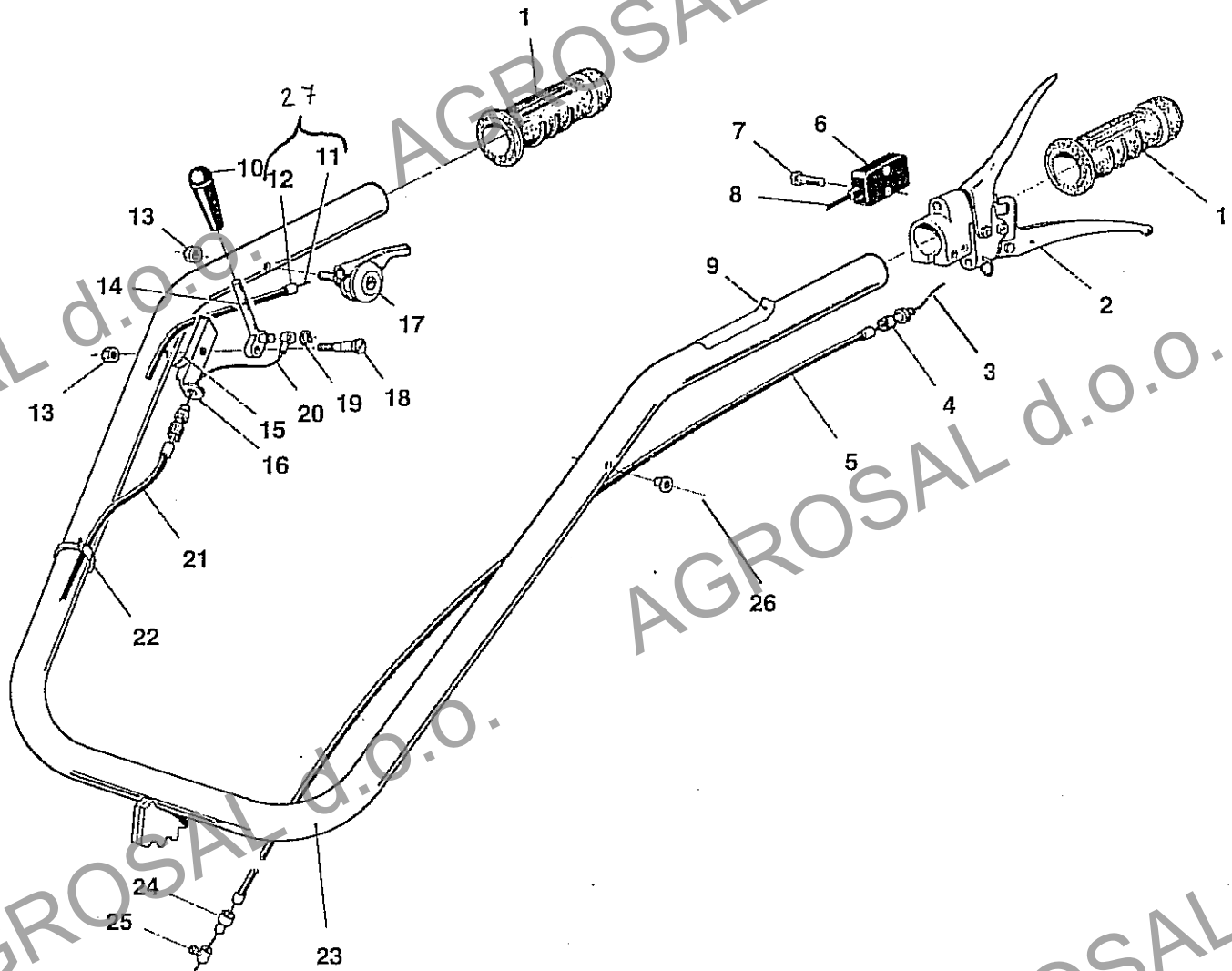

No. pezzo No. pièce No. pièce No. Bild No. pieza	No. di ordinazione Part No. No. de commande Bestell.-Nr. No. de pedido	No. pezzo No. pièce No. pièce No. Bild No. pieza	No. di ordinazione Part No. No. de commande Bestell.-Nr. No. de pedido	No. pezzo No. pièce No. pièce No. Bild No. pieza	No. di ordinazione Part No. No. de commande Bestell.-Nr. No. de pedido
1	N2.8473.00	20	N5.6488.05		
2	N2.8061.10	21	N5.5165.10		
3	N5.6334.00	22	N1.7640.00		
4	N5.8010.00	23	F118.1625		
5	N5.4861.00	24	N5.8534.00		
6	N2.5423.60	25	N5.9016.00		
7	N6.1821.50	26	N5.2508.00		
8	F118.2601	27	N5.4640.00		
9	N5.4070.00				
10	N3.7523.00				
11	N5.6125.00				
12	N5.4640.00				
13	N1.4547.00				
14	F109.1657				
15	F109.1690				
16	F109.1687				
17	N2.8036.50				
18	F106.1613				
19	N.1028.00				

Segnalazioni di validità
Usage code
Signalisations de validité
Gültigkeitsvermerk
Indicaciones de validez

FICHES

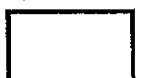

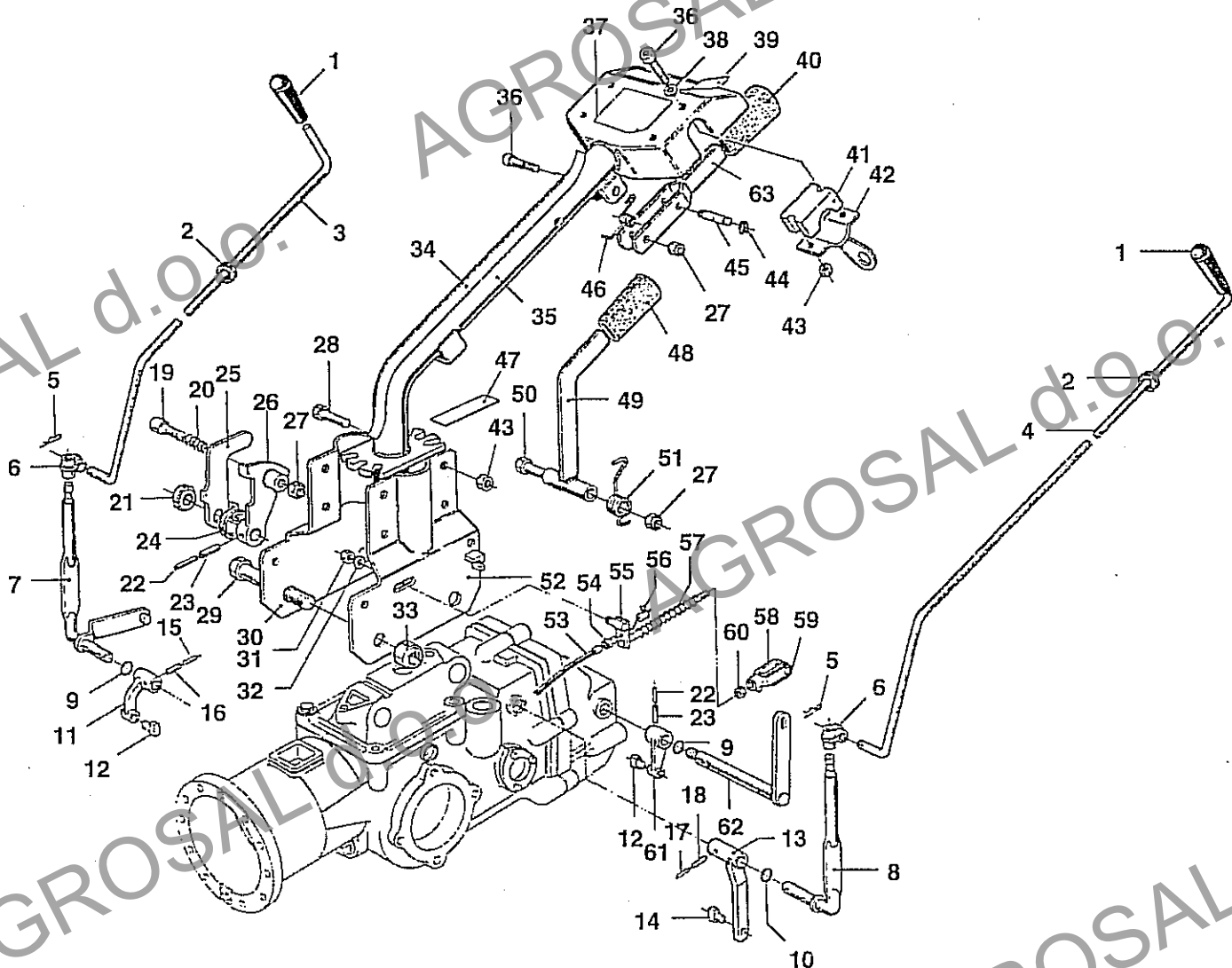

No. pezzo No. pièce No. pièce No. Bild No. pieza	No. di ordinazione Part No. No. de commande Bestell. - Nr. No. de pedido	No. pezzo No. pièce No. pièce No. Bild No. pieza	No. di ordinazione Part No. No. de commande Bestell. - Nr. No. de pedido	No. pezzo No. pièce No. pièce No. Bild No. pieza	No. di ordinazione Part No. No. de commande Bestell. - Nr. No. de pedido
1	N3.7536.00	22	N5.1093.00	43	N1.4588.00
2	N.4029.00	23	N5.1255.00	44	N.1029.00
3	F118.1639	24	F118.1636	45	N5.1356.10
4	F118.1640	25	F118.1634	46	F118.1620
5	N5.1357.00	26	F118.1635	47	F118.1648
6	F106.1633	27	N1.4585.00	48	N2.8404.70
7	F118.1627	28	N6.2724.00	49	F118.1604
8	F118.1615	29	N6.4331.10	50	N6.3000.00
9	N.3176.00	30	F118.1601	51	F118.1605
10	N.3175.00	31	N1.4642.00	52	F118.1602
11	F105.1706	32	N4.3806.00	53	N5.5165.10
12	F105.0831	33	N1.4751.10	54	N5.8534.00
13	F118.0809	34	F118.2109	55	F109.1676
14	F118.0810	35	F118.1624	56	N5.9016.00
15	N5.1040.00	36	N6.2852.00	57	N3.1101.00
16	N5.1173.00	37	F118.2108	58	N6.0058.10
17	N5.1032.00	38	N4.3694.00	59	N6.0058.20
18	N5.1167.00	39	F118.1647	60	N1.4569.00
19	F118.1644	40	N2.8404.80	61	F105.1700
20	N3.1057.00	41	F118.1646	62	F118.1637
21	N2.1008.00	42	F118.1618	63	F118.1643

Segnalazioni di validità
Usage code
Signalisations de validité
Gültigkeitsvermerk
Indicaciones de validez

FICHES

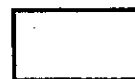

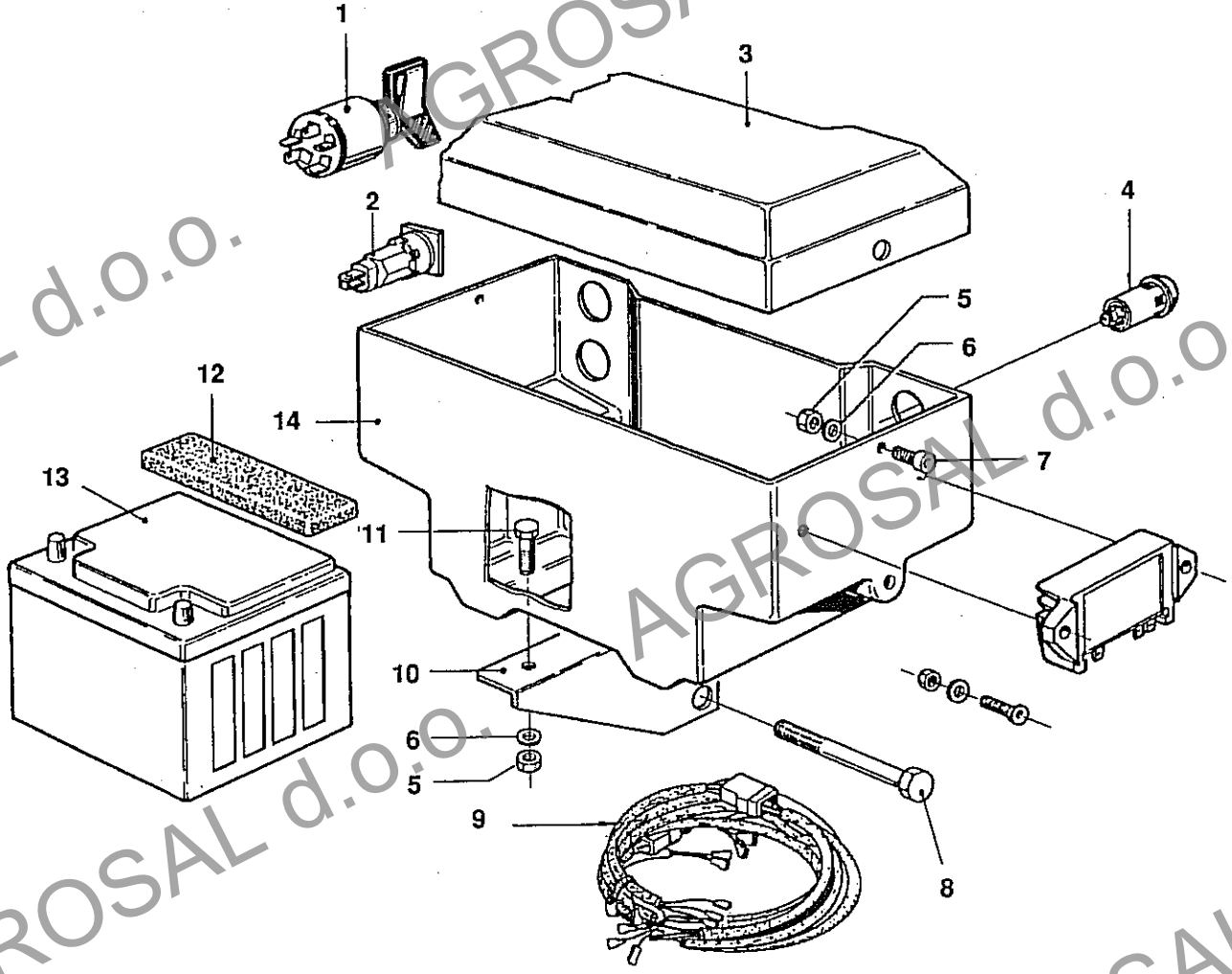

No. pezzo No. pièce No. pièce No. Bild No. pieza	No. di ordinazione Part No. No. de commande Bestell. - Nr. No. de pedido	No. pezzo No. pièce No. pièce No. Bild No. pieza	No. di ordinazione Part No. No. de commande Bestell. - Nr. No. de pedido	No. pezzo No. pièce No. pièce No. Bild No. pieza	No. di ordinazione Part No. No. de commande Bestell. - Nr. No. de pedido
1	N2.5004.20				
2	N2.5522.50				
3	F118.2604				
4	N2.5523.70				
5	N1.4585.00				
6	N4.3685.00				
7	N6.2495.10				
8	N6.4332.10				
9	F118.2607				
10	F118.2605				
-	F118.2606				
11	N6.2555.00				
12	F109.2628				
13	N2.5154.50				
14	F118.2603				

Segnalazioni di validità
Usage code
Signalisations de validité
Gültigkeitsvermerk
Indicaciones de validaz

✎ destra
✎ sinistra

FICHES

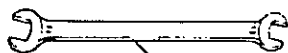
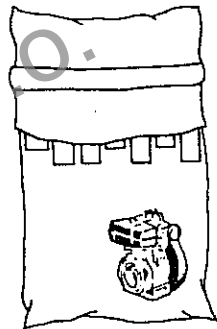

2

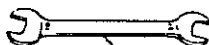

3



4

No. pezzo No. pièce No. pièce No. Bild No. pieza	No. di ordinazione Part No. No. de commande Bestell. - Nr. No. de pedido	No. pezzo No. pièce No. pièce No. Bild No. pieza	No. di ordinazione Part No. No. de commande Bestell. - Nr. No. de pedido	No. pezzo No. pièce No. pièce No. Bild No. pieza	No. di ordinazione Part No. No. de commande Bestell. - Nr. No. de pedido
1	F118.4704				
2	N.7059.00				
3	N.7028.00				
4	N.7021.00				

Segnalazioni di validità
Usage code
Signalisations de validité
Gültigkeitsvermerk
Indicaciones de validez

FICHES



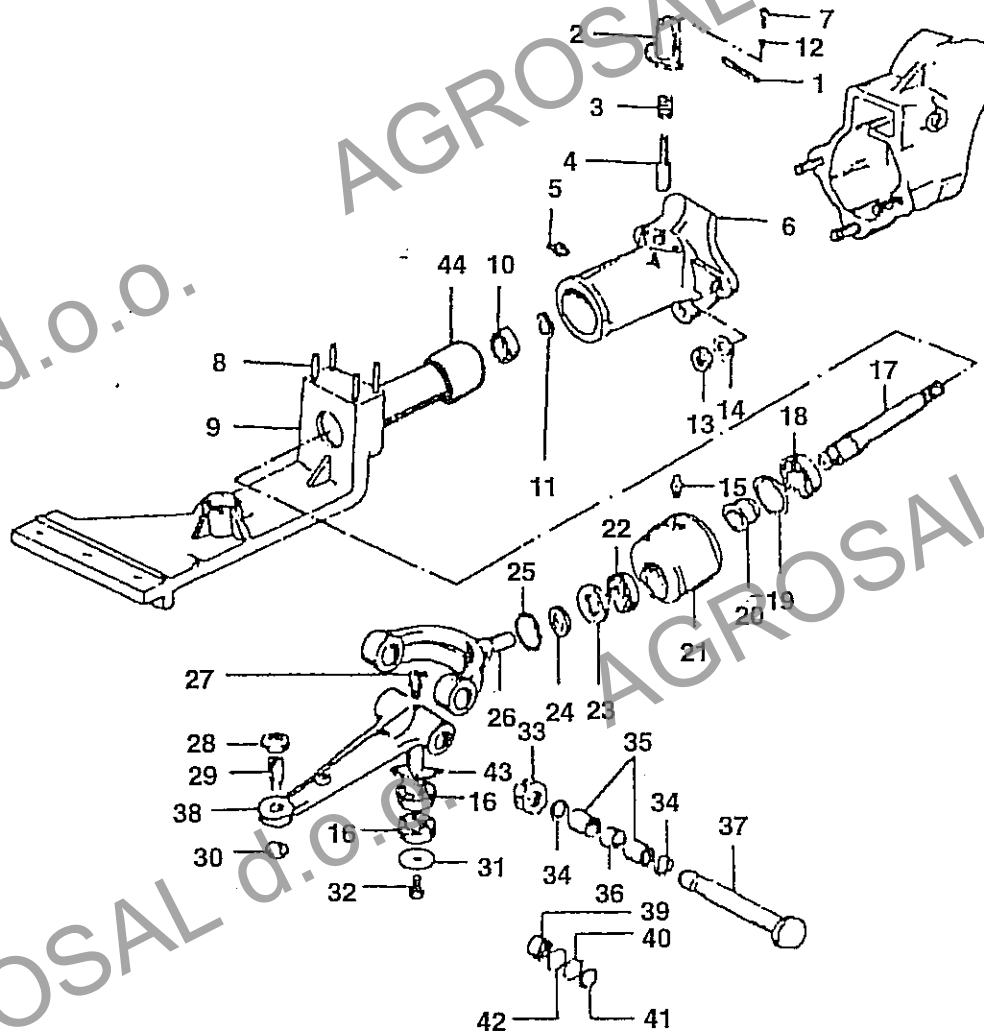

No. pezzo No. piece No. pièce No. Bild No. pieza	No. di ordinazione Part No. No. de commande Bestell. - Nr. No. de pedido	No. pezzo No. piece No. pièce No. Bild No. pieza	No. di ordinazione Part No. No. de commande Bestell. - Nr. No. de pedido	No. pezzo No. piece No. pièce No. Bild No. pieza	No. di ordinazione Part No. No. de commande Bestell. - Nr. No. de pedido
1	N5.1294.50	-	N1.2711.00 Δ b207	33	N2.1016.00 \blacksquare
2	F115.4702	17	F107.3106	34	N5.0028.50 \blacksquare
3	N3.1187.00	18	N1.2711.00	35	N1.2613.50 \blacksquare DNK 20/20 2.0x28x1
4	F105.4710	19	N.1366.00 H 52	36	F107.3190 \blacksquare
5	N2.6056.00	20	F107.3145	37	F107.3191 \blacksquare
6	F01.7010	21	F107.3105	38	F107.3207 \bullet \blacksquare
7	N6.2166.00	22	N1.2583.00 b203	-	F107.3209 \square
8	N3.8109.00	23	N.2057.20	-	F71.1016 \circ
9	F107.3103 \bullet	24	N4.4195.50	39	N1.1534.00 \circ
-	F107.3210 \square	25	N.1300.00 H 40	40	F74.0811 \circ
-	F107.3358 Δ	26	F107.3206	41	N.1208.00 \circ
10	N1.2632.00 b004.2.R5	-	F71.1011 \circ	42	F74.0810 \circ
11	N.1149.00 A20	27	N2.6056.00	43	N5.0054.00 \square
12	N4.3593.00	28	N1.4745.00	44	L381.00
13	N1.4705.00	29	F71.1019		
14	N4.3877.00	30	F71.1018		
15	N2.6056.00	31	N4.3821.50 \bullet		
16	N1.2632.00 \bullet b004.2.R5	-	N4.3821.80 \square		
-	N1.2704.00 \square b005.2.R5	32	N6.3205.00		

Segnalazioni di validità
Usage code
Signalisations de validité
Gültigkeitsvermerk
Indicaciones de validez

\circ 17999 \rightarrow \blacksquare 18000 \rightarrow Δ 32337 \rightarrow
 \bullet \rightarrow 22898 \square 22899 \rightarrow
 CODICE BARRA

FICHES

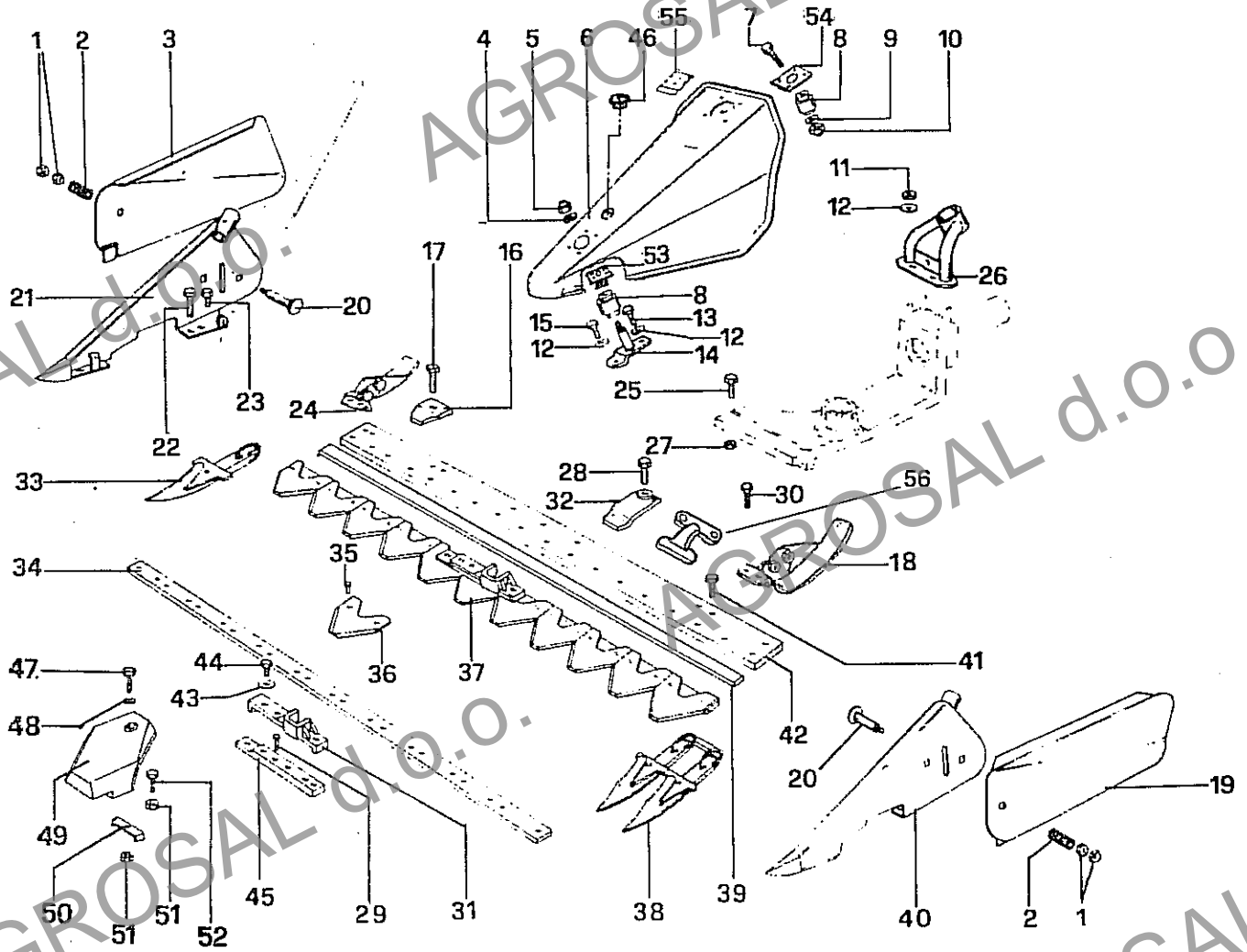

No. pezzo No. pièce No. pièce No. Bild No. pieza	No. di ordinazione Part No. No. de commande Bestell. - Nr. No. de pedido	No. pezzo No. pièce No. pièce No. Bild No. pieza	No. di ordinazione Part No. No. de commande Bestell. - Nr. No. de pedido	No. pezzo No. pièce No. pièce No. Bild No. pieza	No. di ordinazione Part No. No. de commande Bestell. - Nr. No. de pedido
1	N1.4689.00	22	N6.3148.00	-	F71.2031 L=1150
2	N3.1291.00	23	N6.3275.00	-	F59.1593 L=1270
3	F71.2015	24	F107.3170	-	F107.3220 L=1450
4	N84.3812.00	25	N6.3328.00	40	F74.1635
5	N81.4638.00	26	F107.3112	41	N6.3221.00
6	F107.3144	27	N1.4628.00	42	F74.1684 L= 800
-	R107.6067	28	N6.3275.00	-	F74.1685 L= 950
7	N6.4285.00	29	N.8830.00	-	F74.1686 L=1150
-	N6.3997.10	30	N6.3149.00	-	F74.1689 L=1270
8	N4.9244.00	31	F107.3124	-	F107.3192 L=1450
-	N4.9240.00	32	F58.2686	43	N4.3666.00
9	N4.3921.50	33	F58.2738	44	N6.2457.00
-	N4.3844.10	34	F71.2006 L= 800	45	F107.3122
10	N1.4767.60	-	F71.2028 L= 950	46	N5.2612.70
-	N1.4702.00	-	F4.0411 L=1150	47	N6.2908.00 *
11	N1.4580.00	-	F4.0412 L=1270	48	N4.3666.00 *
12	N4.3667.00	-	F107.3218 L=1450	49	F105.3101 *
13	N6.2670.00	35	N.8866.00	50	F105.3102 *
14	F107.3111	36	F58.2091	51	N1.4579.00 *
-	F107.3215	37	F107.3126 L= 800	52	N6.2784.00 *
15	N6.2555.00	-	F107.3127 L= 950	53	P107.6000
16	F58.2687	-	F107.3128 L=1150	-	P898
17	N6.3275.00	-	F107.3150 L=1270	54	F107.3113
18	F107.3171	-	F107.3219 L=1450	55	N5.3921.60
19	F74.1634	38	F58.2688	56	F 58.2685
20	N6.4040.00	39	F71.2008 L= 800		
21	F74.1609	-	F71.2027 L= 950		

Segnalazioni di validità
Usage code
Signalisations de validité
Gültigkeitsvermerk
Indicaciones de validez

* A RICHIESTA → 25655 ↓ DESTRA
 25656 → ↓ SINISTRA

FICHES

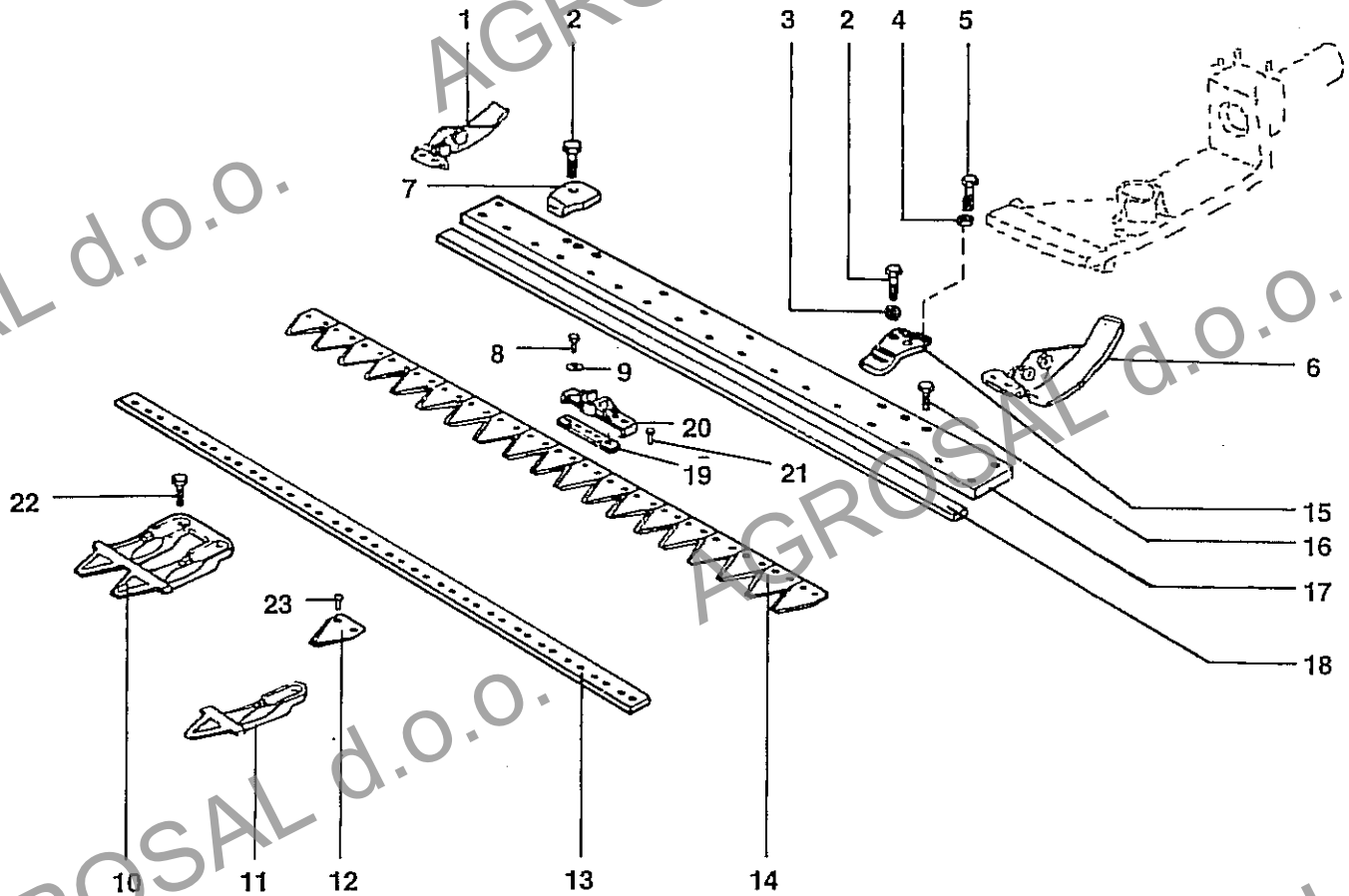

No. pezzo No. pièce No. pièce No. Bild No. pieza	No. di ordinazione Part No. No. de commande Bestell.-Nr. No. de pedido	No. pezzo No. pièce No. pièce No. Bild No. pieza	No. di ordinazione Part No. No. de commande Bestell.-Nr. No. de pedido	No. pezzo No. pièce No. pièce No. Bild No. pieza	No. di ordinazione Part No. No. de commande Bestell.-Nr. No. de pedido
1	F107.3170	13	F107.3125 L=1150	19	F107.3123
2	N6.3333.00	-	F74.1628 L= 950	20	F107.3124
-	N6.2457.00 per tipo doppio	-	F107.3154 L=1270	21	N8880.00
3	F107.3119	14	F107.3137 L=1150 □	22	N6.3221.00
4	N1.4628.00	-	F107.3216 ■	23	N8866.00
5	N6.3153.00	-	F107.3136 L= 950		
6	F107.3171	-	F107.3152 L=1270		
7	F58.2687	-	F107.3194 L=1450		
8	N6.2457.00	15	F107.3118		
9	N4.3666.00	-	F111.3112 tipo doppio		
10	F111.3114	16	N6.3149.00		
11	F111.3113	17	F74.1686 L=1150		
12	F74.1683 □ ▼	-	F74.1685 L= 950		
-	F107.3216 ■ ▼	-	F74.1689 L=1270		
-	F74.1683 □ ▲	-	F107.3192 L=1450		
-	F107.3216 ■ ▼	18	F71.2031 L=1150		
-	F74.1683 ■ ▼	-	F71.2027 L= 950		
-	F107.3216 ■ ▲ ▲	-	F59.1593 L=1270		
		-	F107.3193 L=1450		

Segnalazioni di validità
Usage code
Signalisations de validité
Gültigkeitsvermerk
Indicaciones de validez

△ cm. 115 ▼ cm. 127 □ → 23368 ■ → 25605 ■ → 25781
▲ cm. 145 ▼ cm. 95 ■ 23369 → ■ 25606 → ■ 25782 →

FICHES



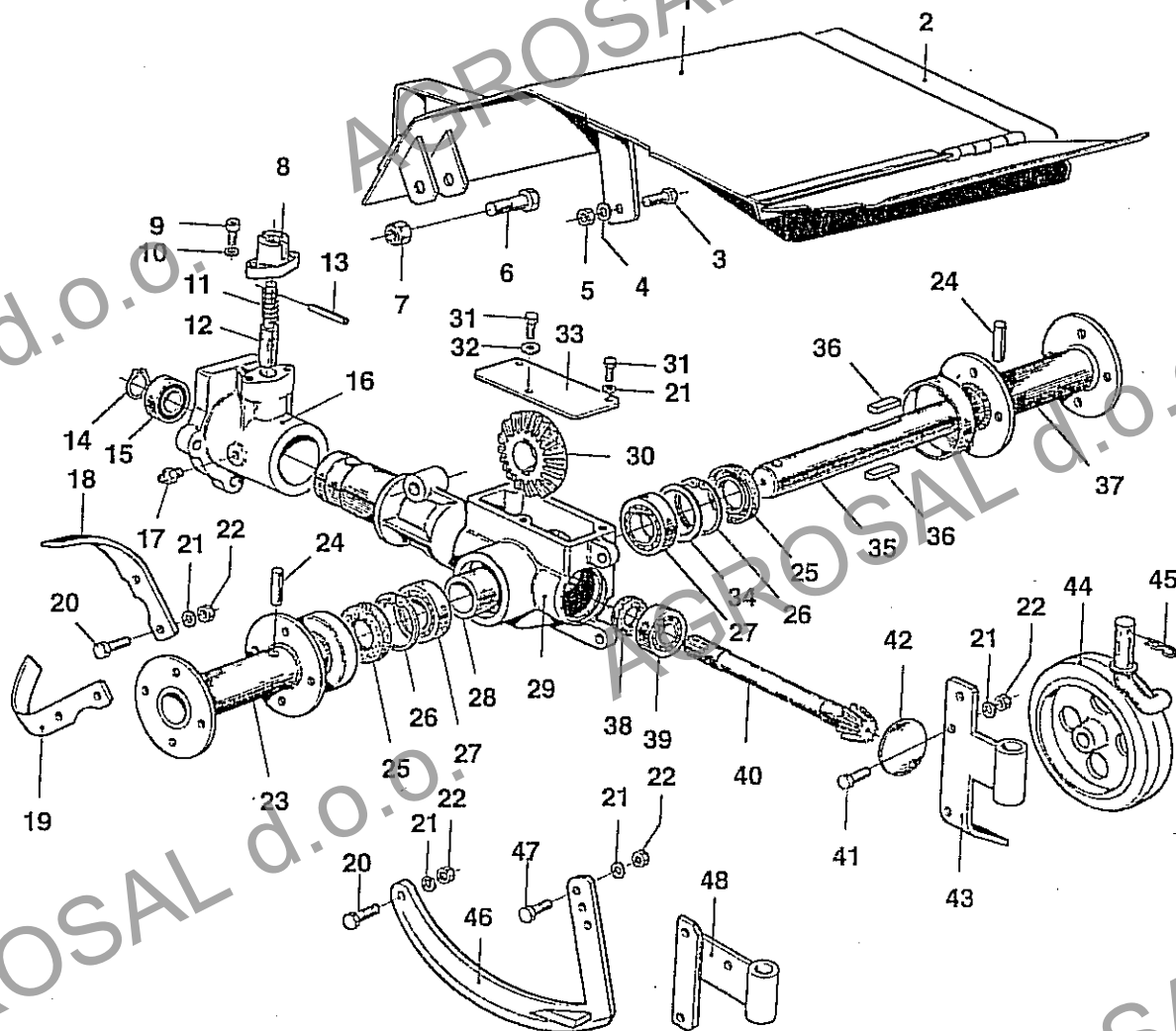

No. pezzo No. pièce No. Bild No. pieza	No. di ordinazione Part No. No. de commande Bestell.-Nr. No. de pedido	No. pezzo No. pièce No. Bild No. pieza	No. di ordinazione Part No. No. de commande Bestell.-Nr. No. de pedido	No. pezzo No. pièce No. Bild No. pieza	No. di ordinazione Part No. No. de commande Bestell.-Nr. No. de pedido
1	F01.7001 ▼	18	F01.7003	35	F01.7016
-	F01.7012 ▲	19	F01.7002	36	N.6517.00
2	F01.7020 ↘	20	N6.2723.00	-	N.6516.10 □
-	F01.7021 ↙	21	N4.3666.00	37	F01.7005
3	N6.2670.00	22	N1.4573.00	-	F01.7011 ★★
4	N4.3667.00	23	F01.7005	38	N.2073.00 0H 20x35x7
5	N1.4574.00	24	F01.7011 ★★	39	N1.2637.01 6204
6	N6.3951.00	25	N5.1431.00	40	F01.7008
7	N1.4701.50	26	N.2124.50 30x55x10	41	N6.2669.00
8	F115.4702	27	N.1380.00 H55	42	N5.2767.00
9	N6.2166.00	28	N1.2745.00 6006	43	F01.7006 ▼
10	N4.3581.10	29	F01.7018	44	F67.1403 ★
11	N3.1187.00	30	F01.7000	45	N5.1497.00 ★
12	F105.4710	31	F01.7017	46	F01.5548 ▲
13	N5.1294.50	32	N6.2493.00	47	N6.2741.00 ▲
14	N.1149.00 A20	33	N4.3647.00	48	F01.7019 ▲
15	N1.2632.00 6004.2 R5	34	F01.7009		
16	F01.7010		N5.0093.20 ○		
17	N2.6056.00		N5.0093.30 ●		

Segnalazioni di validità
Usage code
Signalisations de validité
Gültigkeitsvermerk
Indicaciones de validez

↘ destra ▼ cofano fisso ○ spessore 0,2 ★ a richiesta
 ↙ sinistra ▲ cofano registrabile ● spessore 0,3 ★★ a richiesta per L=350
 □ Linguetta con estremità arrotondate

FICHES



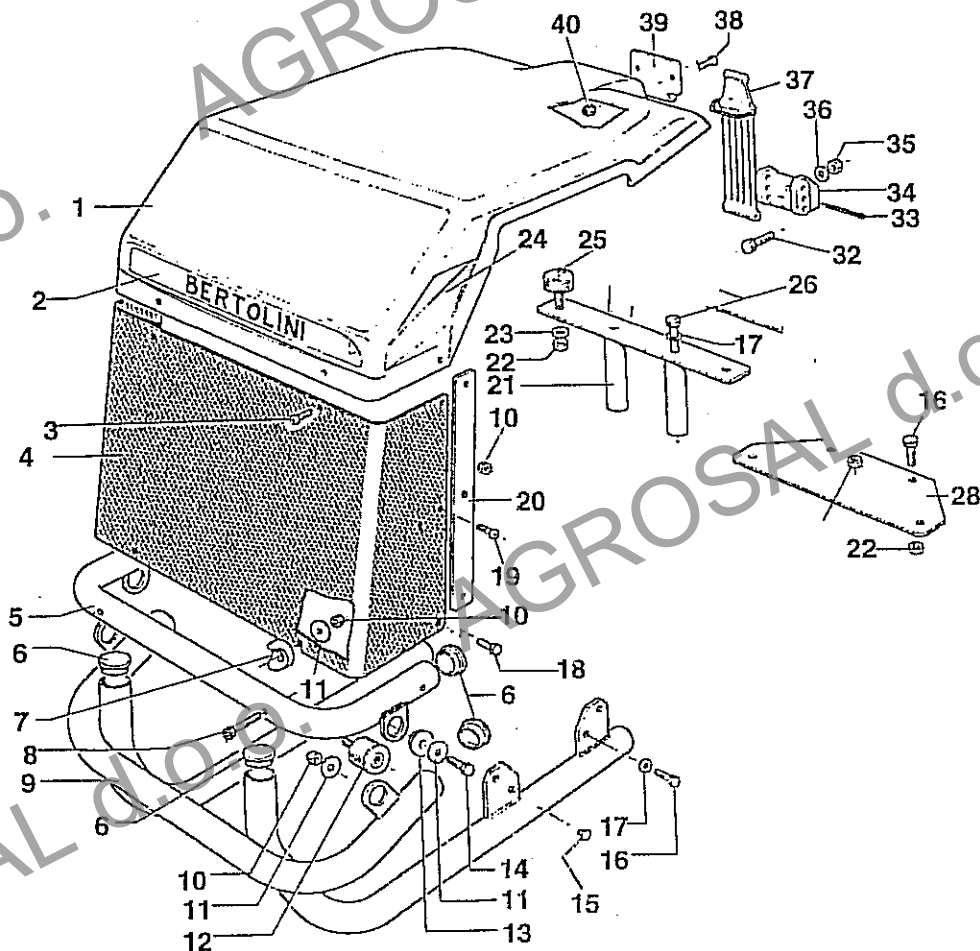

No. pezzo No. pièce No. pièce No. Bild No. pieza	No. di ordinazione Part No. No. de commande Bestell. - Nr. No. de pedido	No. pezzo No. pièce No. pièce No. Bild No. pieza	No. di ordinazione Part No. No. de commande Bestell. - Nr. No. de pedido	No. pezzo No. pièce No. pièce No. Bild No. pieza	No. di ordinazione Part No. No. de commande Bestell. - Nr. No. de pedido
1	F120.2103	18	N6.2345.00	40	N1.4529.80
2	F109.2124	19	N6.1998.00		
-	N5.3813.00 *	20	F120.2118		
3	N6.2097.10	21	F120.2107 (6LD 360)		
4	F109.2118	22	N1.4574.00		
5	F120.2104	23	N4.3667.00		
6	N5.2674.00	24	F120.2121		
7	F120.2109	-	F120.2122		
8	N6.2400.00	25	N4.9206.13		
9	F120.2106 (6LD 360)	26	N6.3079.00		
-	F120.2110 (MC71)	28	F120.2120 (MC71)		
10	N1.4547.00	32	N6.2555.00		
11	N4.3622.00	33	N1.0608.00		
12	N4.9205.50	34	F120.2123		
13	F75.2170	35	N1.4585.00		
14	N6.2097.10.	36	N4.3694.00		
15	N5.2524.20	37	F120.2124		
16	N6.2488.00	38	N6.1929.80		
17	N4.3649.00	39	F120.2127		

Segnaiazioni di validità
Usage code
Signalisations de validité
Gültigkeitsvermerk
Indicaciones de validez

✎ destra
✎ sinistra

* GEMAC

FICHES



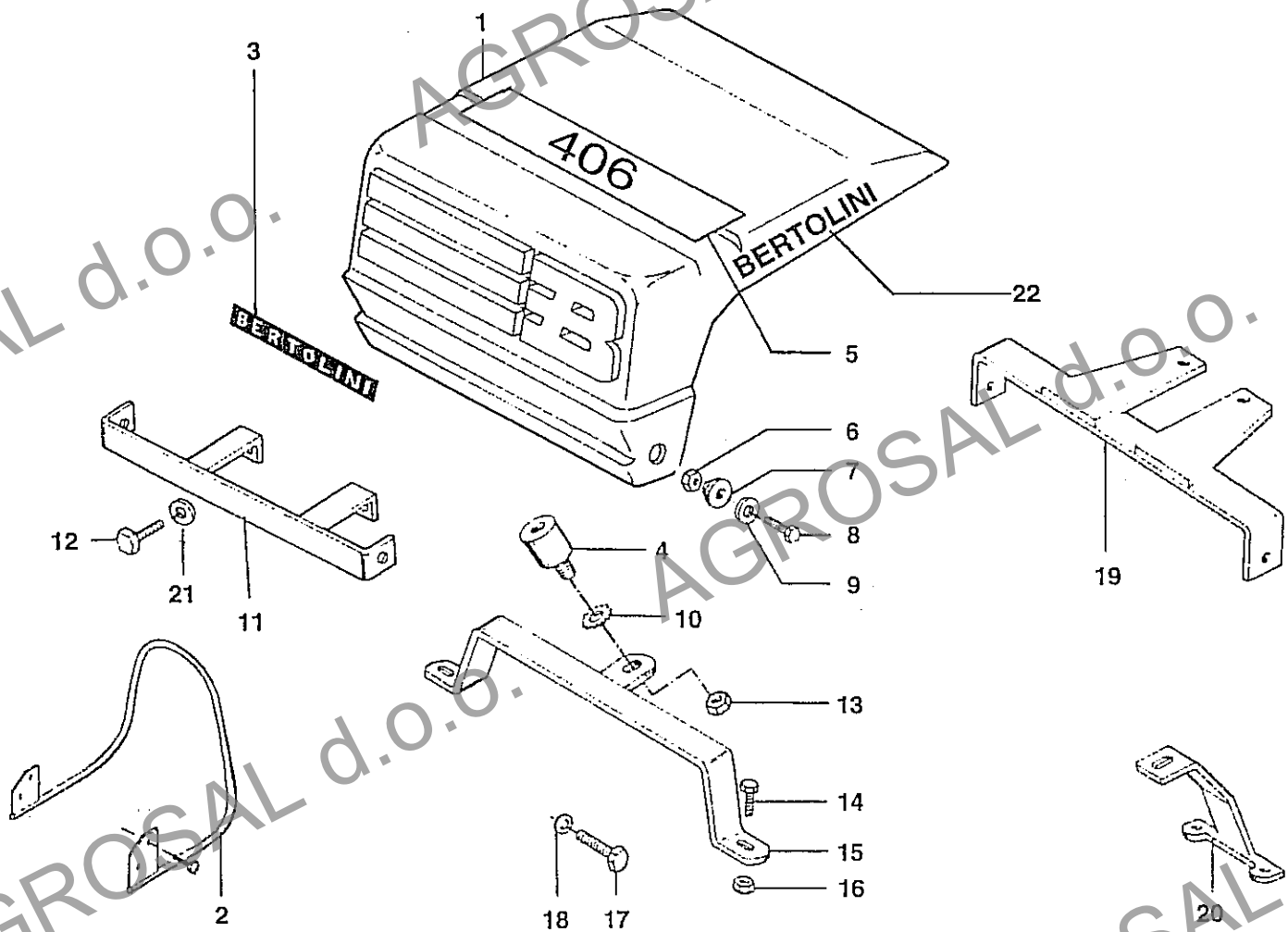

No. pezzo No. piece No. pièce No. Bild No. pieza	No. di ordinazione Part No. No. de commande Bestell.-Nr. No. de pedido	No. pezzo No. piece No. pièce No. Bild No. pieza	No. di ordinazione Part No. No. de commande Bestell.-Nr. No. de pedido	No. pezzo No. piece No. pièce No. Bild No. pieza	No. di ordinazione Part No. No. de commande Bestell.-Nr. No. de pedido
1	F105.2112 ▲	17	N6.2488.00		
-	F105.2114 ▼	18	N4.3649.00 ▲		
2	F109.2102 ▲▼	19	F75.2164		
-	F120.2102 ✕△	20	F75.2165 ▲		
3	F105.2116	21	N4.3667.00 ▼		
4	F75.2159	22	F118.2107 △		
5	F120.2101				
-	F120.2126 *				
6	N1.4547.00				
7	F75.2170				
8	N6.2210.00				
9	N4.3622.00				
10	N4.3667.00				
11	F105.2120 ▼				
12	N6.2555.00 ▼				
13	N1.4574.00				
14	N6.2491.00 ▼				
15	F105.2121 ▼				
16	N1.4585.00 ▼				

Segnalazioni di validità
Usage code
Signalisations de validité
Guilfigkeitsvermerk
Indicaciones de validez

▲ motore 6LD 360
▼ motore MC71

* Targhetta "GEMAC"
△ IM 350 - CA340

~~▲ IM 950~~

FICHES



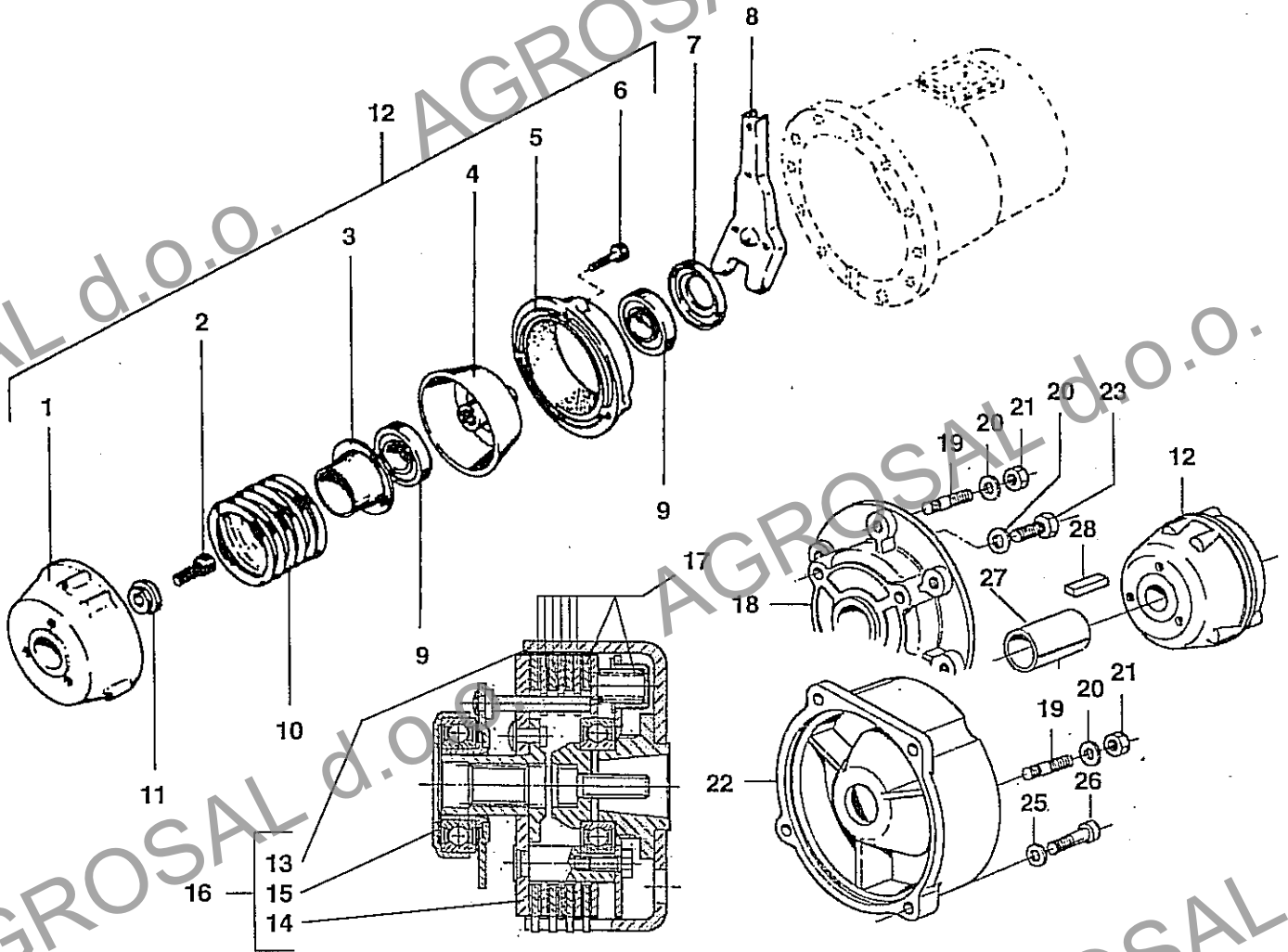

No. pezzo No. piece No. pièce No. Bild No. pieza	No. di ordinazione Part No. No. de commande Bestell. - Nr. No. de pedido	No. pezzo No. piece No. pièce No. Bild No. pieza	No. di ordinazione Part No. No. de commande Bestell. - Nr. No. de pedido	No. pezzo No. piece No. pièce No. Bild No. pieza	No. di ordinazione Part No. No. de commande Bestell. - Nr. No. de pedido
1	F75.0001	-	P1008 ○		
-	F105.0029 ○	-	P1009 ●		
-	F105.0032 ●	13	F109.0003		
2	N6.2892.00 △	14	F109.0004		
-	N6.2680.00 ▲▼	15	F109.0005		
-	N6.2439.50 ○	16	F109.0002		
-	N6.3670.10 ●	17	F109.0006		
3	F105.0005	18	F105.0027		
4	F105.0006	19	N3.8125.00		
5	F75.0004	20	N4.3654.00		
6	N6.2348.00	21	N1.4574.00		
7	F75.0014	22	F105.0031		
8	F75.0011	23	N6.2439.80		
9	N1.2632.01 <i>6004.2 R5</i>	25	N4.3764.00		
10	N3.1381.86	26	N6.3097.90		
11	F105.0003	27	F105.0028 ○		
-	F105.0033 ●	-	F105.0030 ●		
12	P443 ▲▼	28	N.6434.10 ○		
-	P863 △	-	N.6480.80 ●		

Segnalazioni di validità
Usage code
Signalisations de validité
Gültigkeitsvermerk
Indicaciones de validez

▲ 6 LD 360
MC 71

▼ IM 300
IM 350
CA 340

△ ALN 330

○ HONDA GX 140
B. & STRATTON

● HONDA GX 240
B. & STRATTON

FICHES



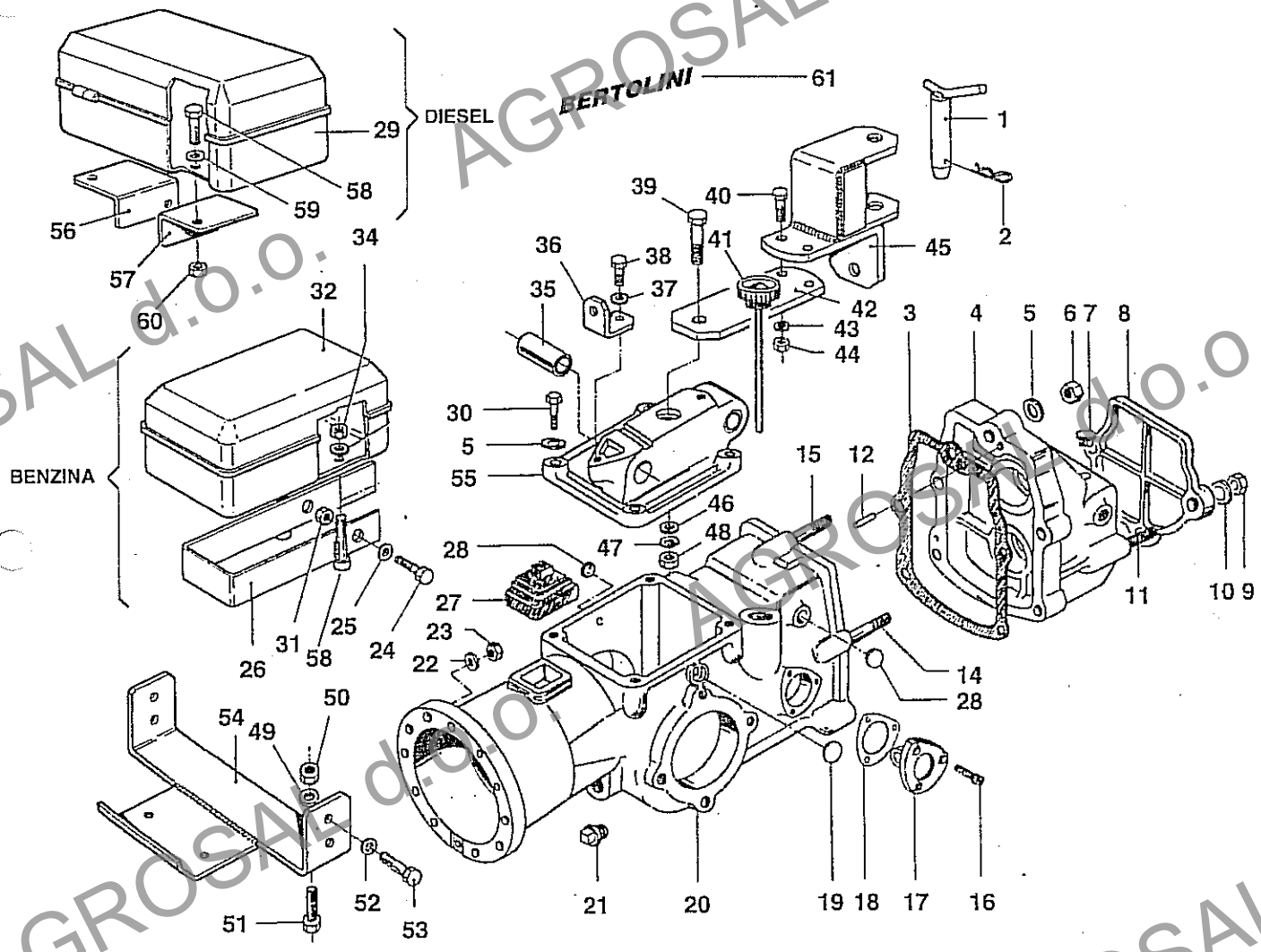

No. pezzo No. piece No. pièce No. Bild No. pieza	No. di ordinazione Part No. No. de commande Bestell.-Nr. No. de pedido	No. pezzo No. piece No. pièce No. Bild No. pieza	No. di ordinazione Part No. No. de commande Bestell.-Nr. No. de pedido	No. pezzo No. piece No. pièce No. Bild No. pieza	No. di ordinazione Part No. No. de commande Bestell.-Nr. No. de pedido
1	F75.1647	22	N4.3654.00	46	N4.3844.00
2	N5.1488.00	23	N1.4574.00	47	N4.3905.00
3	F105.0822	24	N6.2488.00	48	N1.4695.00
4	F105.0834	25	N4.3649.00	49	N1.4574.00 ○
5	N4.3763.00	26	F118.2104	-	N1.4632.00 ⊕
6	N1.4620.00	27	F75.1646	50	N4.3654.00 ○
7	N75.0835	28	N5.2562.00	-	N4.3764.00 ⊕
8	F105.0833	29	F120.2125	51	N6.2741.00 ○
9	N1.4705.00	30	N6.3275.00	-	N6.3328.00 ⊕
10	N4.3877.00	31	N1.4574.00	52	N4.3649.00
11	N3.8615.00	32	F118.2105	53	N6.2488.00
12	N5.1264.00	34	N1.4574.00	54	F105.2122 *
-	N5.1243.00 □	35	N4.9247.00	-	F105.2126 ○★
14	N3.8399.00 □ n°2	36	F107.1617	-	F105.2104 ⊕★
-	N3.8363.00 □ n°2	37	N4.3667.00	-	F120.2102 ✦
-	N3.8412.00 ⊠ n°2	38	N6.2621.00	55	F107.0801
15	N3.8420.00	39	N6.4066.00	56	F118.2101
16	N6.2108.00	40	N6.3254.00	57	F118.2102
17	F105.0804	41	N5.3506.00	58	N6.2097.10
18	F105.0827	42	F118.2103	59	N4.3622.00
19	N5.2613.00	43	N4.3799.00	60	N1.4547.00
20	F105.0801	44	N1.4632.00	61	F118.2107 *
21	N5.2540.00	45	F118.4701		

Segnalazioni di validità
 Usage code
 Signallsations de validité
 Gültigkeitsvermerk
 Indicaciones de validez

✦ motori benzina
 * A 220

○ HONDA GX 140
 ⊕ HONDA GX 240
 ★ B. & STRATTON

✦ DESTRA
 ✦ SINISTRA

□ → 1780
 ⊠ 1781 →

FICHES

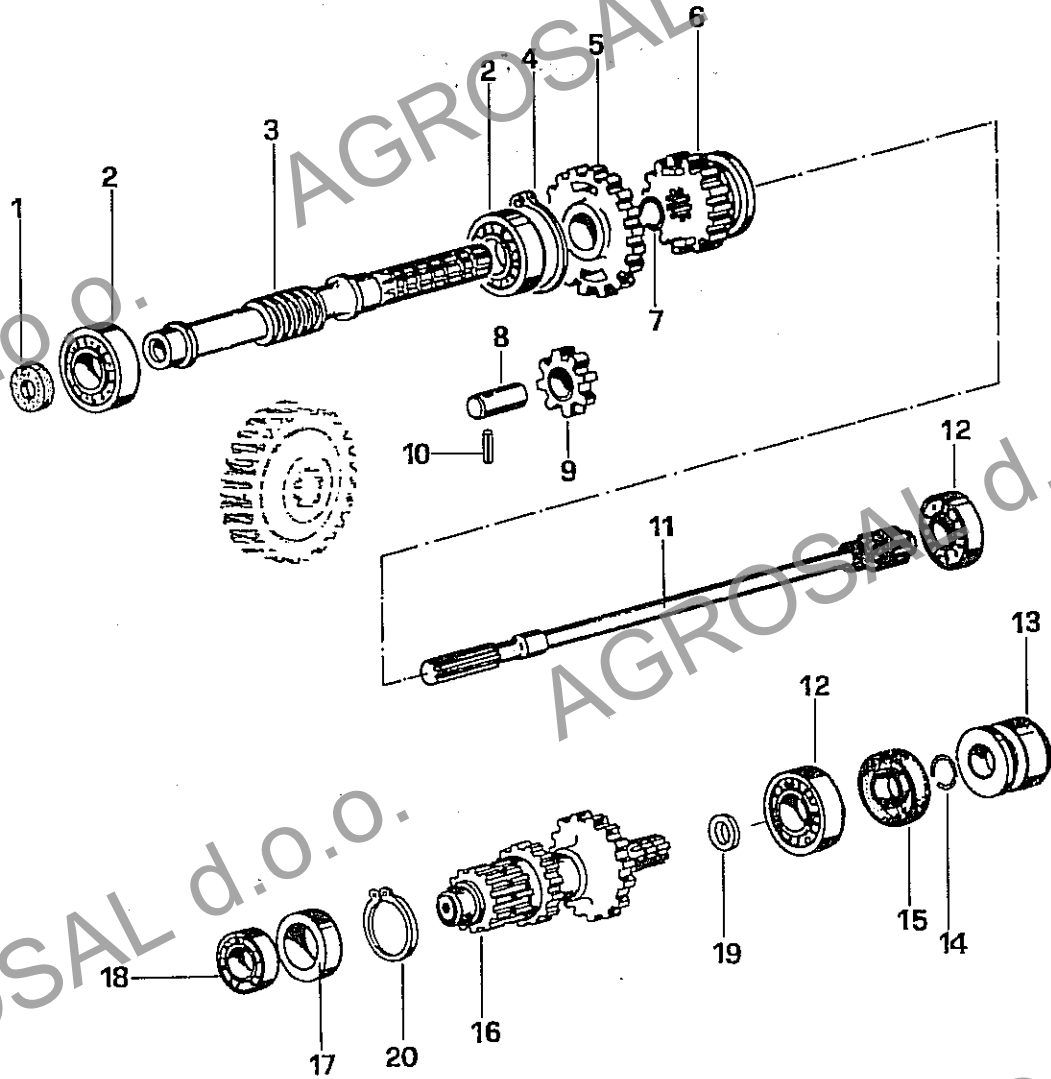

No. pezzo No. pièce No. de commande No. Bild No. pieza	No. di ordinazione Part No. No. de commande Bestell. - Nr. No. de pedido	No. pezzo No. pièce No. de commande No. Bild No. pieza	No. di ordinazione Part No. No. de commande Bestell. - Nr. No. de pedido	No. pezzo No. pièce No. de commande No. Bild No. pieza	No. di ordinazione Part No. No. de commande Bestell. - Nr. No. de pedido
1	N.2047.50	20	N.1310.00 A42		
2	N1.2707.00 b205				
3	F105.0835				
4	N.1368.00 A52				
5	F105.0813				
6	F105.0812				
7	N.0046.50				
8	F105.0826				
9	F105.0811				
10	N5.1014.50				
11	F105.0805				
12	N1.2637.00 b204				
13	P105.6009				
14	F105.0821				
15	N.2073.00 20x35x7				
16	F105.0808				
17	F105.0824				
18	N1.2570.00 b202				
19	N5.0089.10				

Segnalazioni di validità
Usage code
Signalisations de validité
Gültigkeitsvermerk
Indicaciones de validez

FICHES



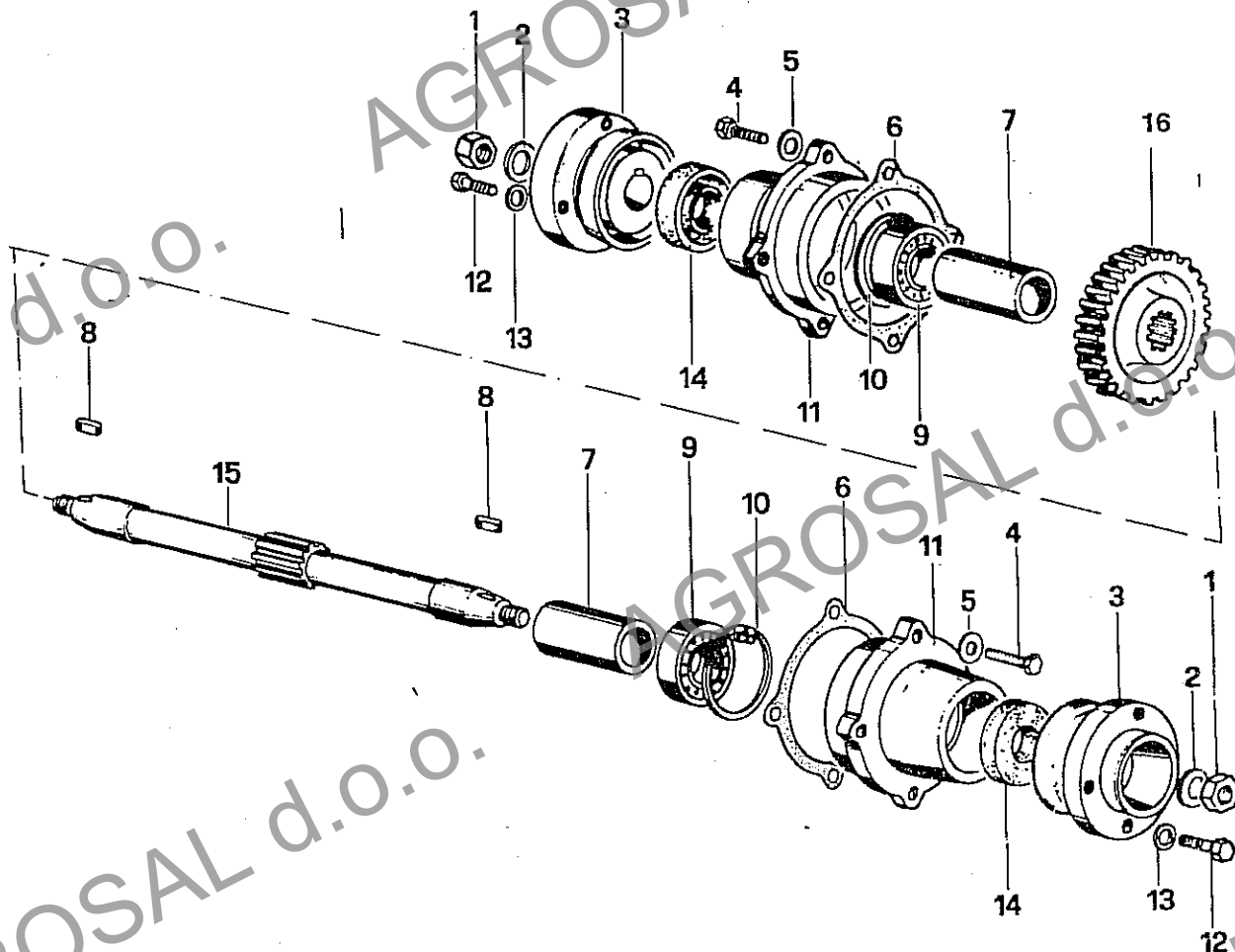

No. pezzo No. pièce No. pièce No. Bild No. pieza	No. di ordinazione Part No. No. de commande Bestell. - Nr. No. de pedido	No. pezzo No. pièce No. pièce No. Bild No. pieza	No. di ordinazione Part No. No. de commande Bestell. - Nr. No. de pedido	No. pezzo No. pièce No. pièce No. Bild No. pieza	No. di ordinazione Part No. No. de commande Bestell. - Nr. No. de pedido
1	N1.4798.00				
2	N4.4030.00				
3	F105.0223				
4	N6.2669.00				
5	N4.3649.00				
6	F105.0202				
7	F105.0205				
8	N.6468.00				
9	N1.2707.00 6205				
10	N.1368.00 H52				
11	F105.0201				
12	N6.3220.00				
13	N4.3799.00				
14	N.2100.50 0X25x52x7				
15	F105.0203				
16	F105.0836				

Segnalazioni di validità
Usage code
Significations de validité
Gültigkeitsvermerk
Indicaciones de validaz

FICHES

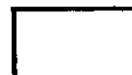

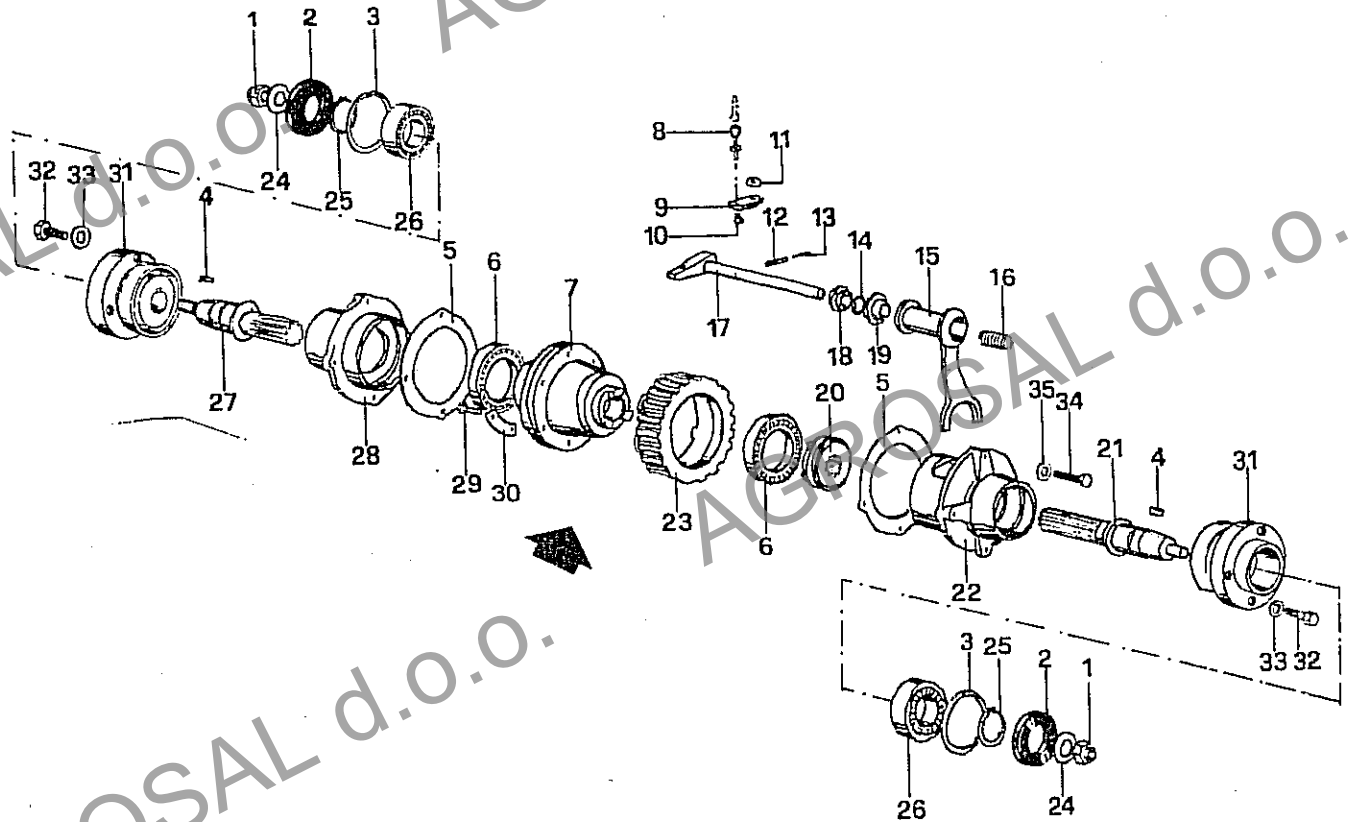

No. pezzo No. piece No. pièce No. Bild No. pieza	No. di ordinazione Part No. No. de commande Bestell.-Nr. No. de pedido	No. pezzo No. piece No. pièce No. Bild No. pieza	No. di ordinazione Part No. No. de commande Bestell.-Nr. No. de pedido	No. pezzo No. piece No. pièce No. Bild No. pieza	No. di ordinazione Part No. No. de commande Bestell.-Nr. No. de pedido
1	N1.4798.00	20	F105.0212		
2	N2100.50 $\phi K25 \times 52 \times 7$	21	F105.0210		
3	N1368.00 H 52	22	F105.0207		
4	N6468.00	23	F105.0241		
5	F105.0202	24	N4.4030.00		
6	N1.2891.00 16008	25	N1185.00 A25		
7	F105.0211	26	N1.2707.01 6205		
8	N5.8010.00	27	F105.0209		
9	F105.1642	28	F105.0206		
10	N5.9016.00	29	N6.2545.00		
11	N4.3798.00	30	F105.0213		
12	N5.1191.00	31	F105.0223		
13	N5.1055.00	32	N6.3220.00		
14	N3176.00	33	N4.3799.00		
15	F105.1654	34	N6.2669.00		
16	N3.1195.60	35	N4.3649.00		
17	F109.1686				
18	F105.1625				
19	F105.1649				

Segnalazioni di validità
Usage code
Signalisations de validité
Gültigkeitsvermerk
Indicaciones de validez

FICHES



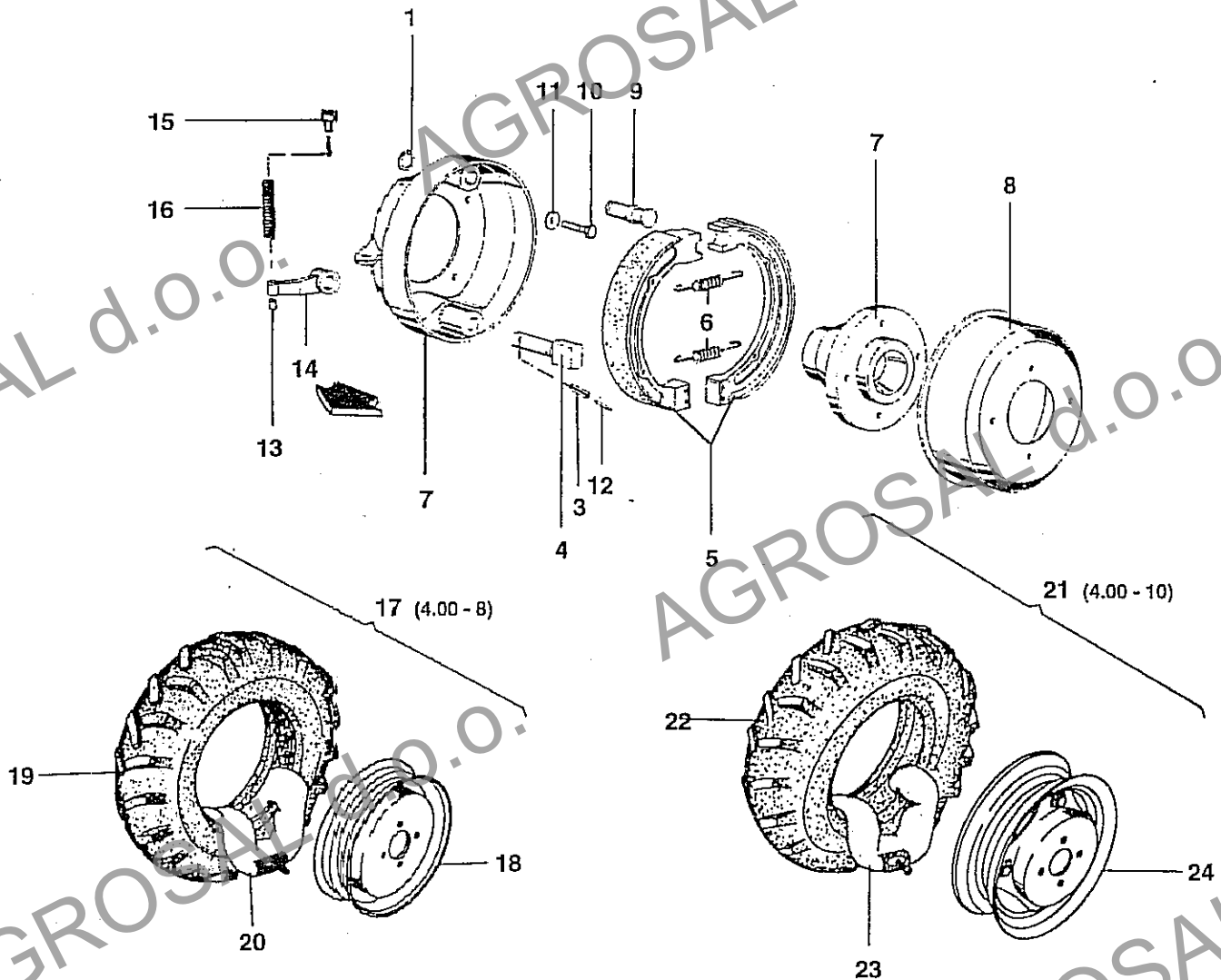

No. pezzo No. pièce No. de commande No. Bild No. pieza	No. di ordinazione Part No. No. de commande Bestell. - Nr. No. de pedido	No. pezzo No. pièce No. de commande No. Bild No. pieza	No. di ordinazione Part No. No. de commande Bestell. - Nr. No. de pedido	No. pezzo No. pièce No. de commande No. Bild No. pieza	No. di ordinazione Part No. No. de commande Bestell. - Nr. No. de pedido
1	N.1072.00	17	P.559		
2	F105.0217	18	N4.9008.20		
-	F105.0218	19	N4.8516.00		
3	N5.1173.00	20	N4.8811.20		
4	F105.0221	-	N4.8811.00		
-	F105.0220	21	P.605		
5	N2.3627.00	22	N4.8520.00		
6	N3.1051.00	23	N4.8815.00		
7	F105.0204	24	N4.9015.90		
8	N2.8827.00				
9	F105.0219				
10	N6.2691.00				
11	N4.3666.00				
12	N5.1040.00				
13	N5.9016.00				
14	F105.1641				
15	N5.8534.00				
16	N3.1010.50				

Segnalazioni di validità
Usage code
Signalisations de validité
Gültigkeitsvermerk
Indicaciones de validez

destra CONTINENTAL
 sinistra CEAT

FICHES



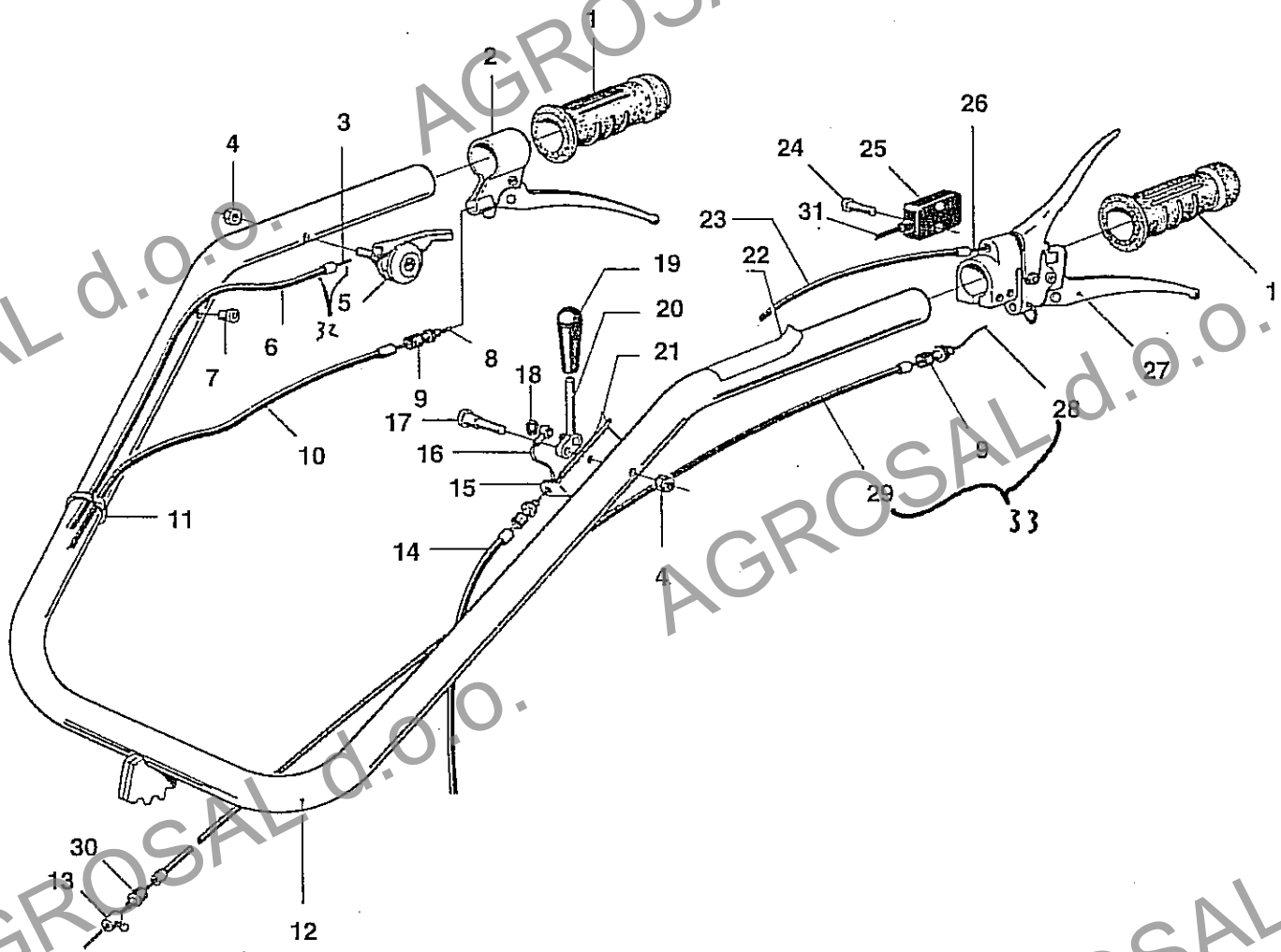

No. pezzo No. piece No. pièce No. Bild No. pieza	No. di ordinazione Part No. No. de commande Bestell. - Nr. No. de pedido	No. pezzo No. piece No. pièce No. Bild No. pieza	No. di ordinazione Part No. No. de commande Bestell. - Nr. No. de pedido	No. pezzo No. piece No. pièce No. Bild No. pieza	No. di ordinazione Part No. No. de commande Bestell. - Nr. No. de pedido
1	N2.8473.00	15	F115.1627	33	N5486100
2	N2.8062.00 ●	16	N5.6485.05		
-	N2.8061.00 ○	17	F106.1613		
3	N5.6126.50 △	18	N.1028.00		
-	N5.6125.00 ▲ ■	19	N3.7523.00		
4	N1.4547.00	20	F115.1632		
5	N2.8036.50	21	F105.1680		
6	N5.4640.00 ▲	22	N5.4070.00		
-	N5.4641.50 △	23	N5.4760.50 ▲		
-	N5.4639.50 ■	-	N5.4760.30 ■		
-	N5.4641.60 □	24	N6.1821.50		
7	N5.2508.00	25	N2.5423.60		
8	N5.6359.10 ★	26	N5.6240.50 ▲ ■		
9	N5.8010.00	27	N2.8061.10		
10	N5.4902.00 ★	28	N5.6334.00		
11	N1.7640.00	29	N5.4861.00		
12	F118.1625	30	N5.8534.00		
13	N5.9016.00	31	F118.2601		
14	N5.5158.40	32	N5464000		

Segnalazioni di validità
Usage code
Signalisations de validité
Gültigkeitsvermerk
Indicaciones de validez

▲ per motori AGME A220 - INTERMOTOR 6L D360
△ per motori ALN330 - CA340
■ per motori MC 71

○ un freno
● due freni
□ per motori HONDA

★ per freno destro e sinistro

FICHES



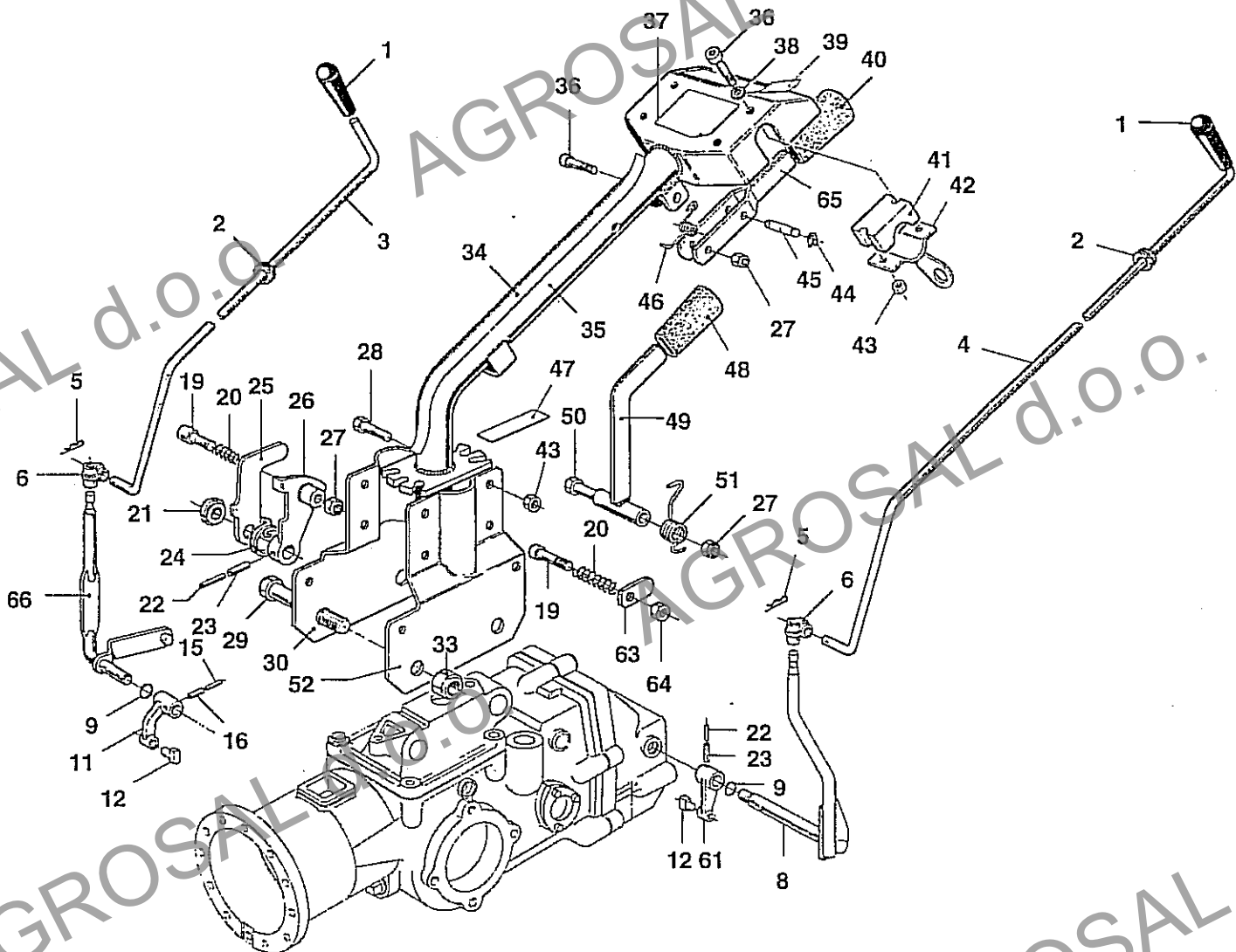

No. pezzo No. pièce No. pièce No. Bild No. pieza	No. di ordinazione Part No. No. de commande Bestell. - Nr. No. de pedido	No. pezzo No. pièce No. pièce No. Bild No. pieza	No. di ordinazione Part No. No. de commande Bestell. - Nr. No. de pedido	No. pezzo No. pièce No. pièce No. Bild No. pieza	No. di ordinazione Part No. No. de commande Bestell. - Nr. No. de pedido
1	N3.7536.00	23	N5.1255.00	45	N5.1356.10
2	N.4029.00	24	F118.1636	46	F118.1620
3	F118.1639	25	F118.1634	47	F120.1610
4	F118.1640	26	F118.1635	48	N2.8404.70
5	N5.1357.00	27	N1.4585.00	49	F118.1604
6	F106.1633	28	N6.2724.00	50	N6.3000.00
7	F118.1627	29	N6.4331.10	51	F118.1605
8	F120.1607	30	F120.1601	52	F120.1602
9	N.3176.00	31	N1.4642.00	53	N5.5165.10
10	N.3175.00	32	N4.3812.20	54	N5.8534.00
11	F105.1706	33	N1.4751.10	55	F109.1676
12	F105.0831	34	F118.2109	56	N5.9016.00
13	F118.0809	35	F118.1624	57	N3.1101.00
14	F118.0810	36	N6.2852.00	58	N6.0058.10
15	N5.1040.00	37	F118.2108	59	N6.0058.20
16	N5.1173.00	38	N4.3694.00	60	N1.4569.00
17	N5.1032.00	39	F120.1609	61	F105.1700
18	N5.1167.00	40	N2.8404.80	62	F118.1637
19	F118.1644	41	F118.1646	63	F120.1608
20	N3.1057.00	42	F118.1618	64	N1.4574.00
21	N2.1008.00	43	N1.4588.00	65	F118.1643
22	N5.1093.00	44	N.1029.00	66	F120.1604

Segnalazioni di validità
Usage code
Signalisations de validité
Gültigkeitsvermerk
Indicaciones de validez

FICHES

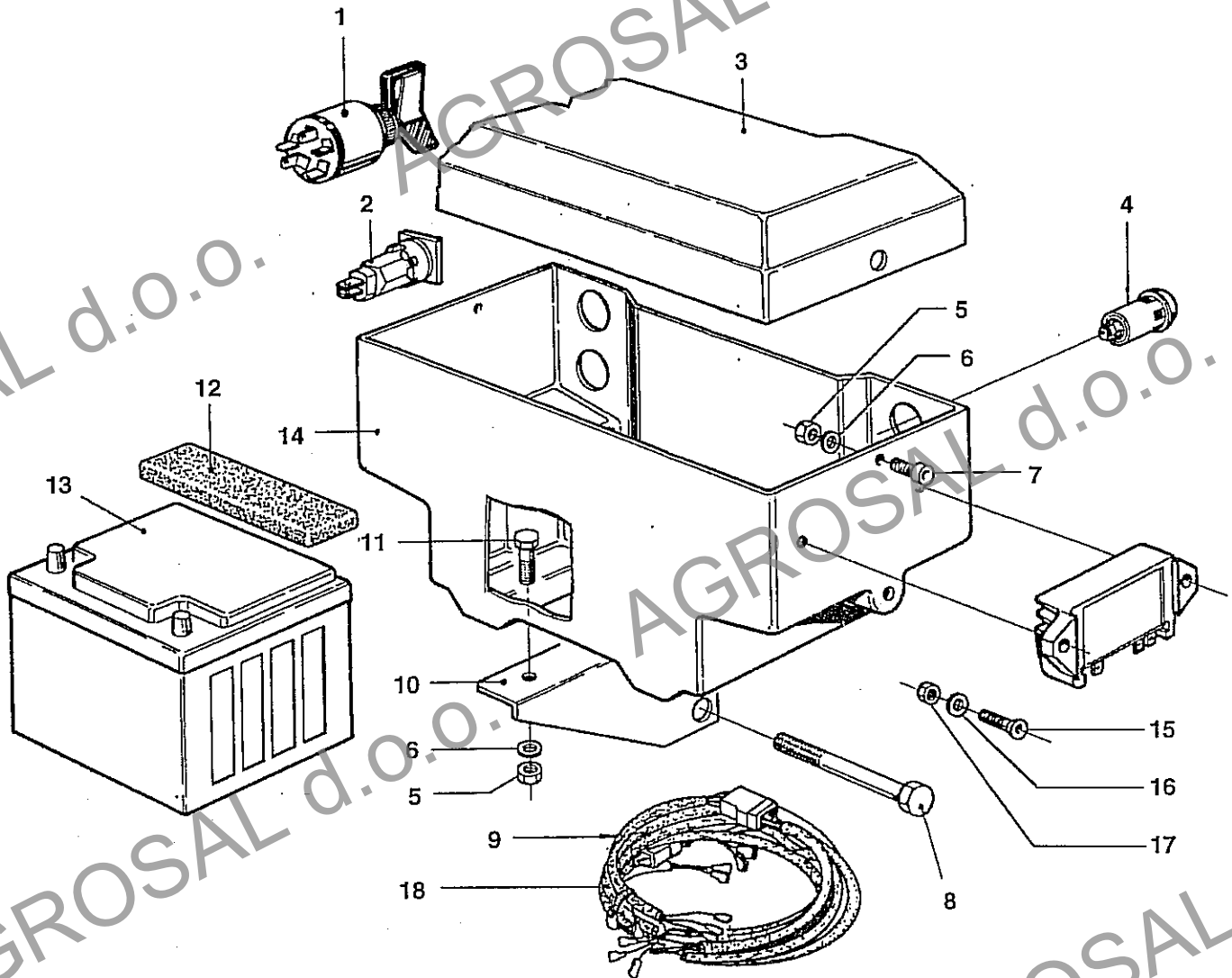

No. pezzo No. pièce No. pièce No. Bild No. pieza	No. di ordinazione Part No. No. de commande Bestell.-Nr. No. de pedido	No. pezzo No. pièce No. pièce No. Bild No. pieza	No. di ordinazione Part No. No. de commande Bestell.-Nr. No. de pedido	No. pezzo No. pièce No. pièce No. Bild No. pieza	No. di ordinazione Part No. No. de commande Bestell.-Nr. No. de pedido
1	N2.5004.20	16	N4.3542.00 ▲		
2	N2.5522.50	-	N4.3585.00 △▼		
3	F118.2604	17	N1.4529.80 ▲		
4	N2.5523.70	-	N1.4547.00 △▼		
5	N1.4585.00	18	F109.2621 ★▲		
6	N4.3685.00	-	F109.2623 ★△		
7	N6.2495.10	-	F109.2625 ★▼		
8	N6.4332.10				
9	F109.2622 ●▲				
-	F109.2624 ●△				
-	F109.2626 ●▼				
10	F118.2605 🖐️				
-	F118.2606 🖐️				
11	N6.2555.00				
12	F109.2628				
13	N2.5154.50				
14	F118.2603				
15	N6.1934.85 ▲				
-	N6.2185.00 △▼				

Segnalazioni di validità
Usage code
Signalfications de validité
Gültigkeitsvermerk
Indicaciones de validez

▲ ALN 330 ● cavi avviamento elettrico 🖐️ destra
△ IM350 ★ impianto completo avviamento elettrico 🖐️ sinistra
▼ 6 LD 360

FICHES
[]

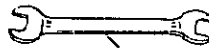
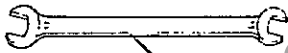
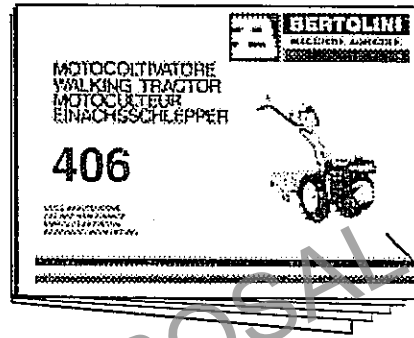
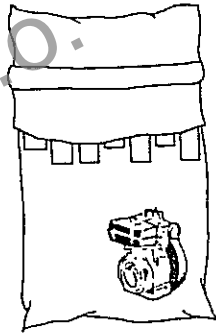

No. pezzo No. piece No. pièce No. Bild No. pieza	No. di ordinazione Part No. No. de commande Bestell. - Nr. No. de pedido	No. pezzo No. piece No. pièce No. Bild No. pieza	No. di ordinazione Part No. No. de commande Bestell. - Nr. No. de pedido	No. pezzo No. piece No. pièce No. Bild No. pieza	No. di ordinazione Part No. No. de commande Bestell. - Nr. No. de pedido
1	F120.4701				
2	N.7059.00				
3	N.7028.00				
4	N.7021.00				

Segnalazioni di validità
Usage code
Signalisations de validité
Gültigkeitsvermerk
Indicaciones de validez

FICHES

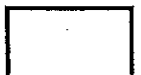

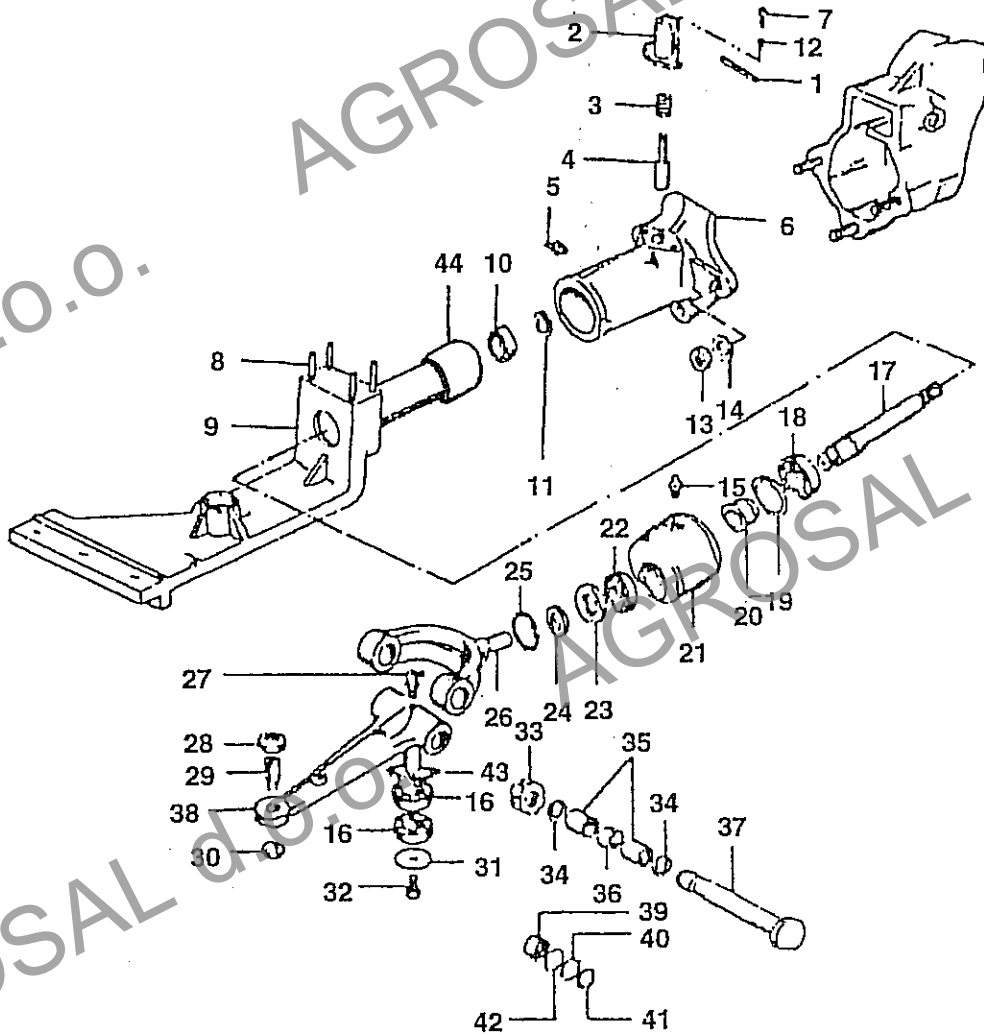

No. pezzo No. pièce No. pièce No. Bild No. pieza	No. di ordinazione Part No. No. de commande Bestell.-Nr. No. de pedido	No. pezzo No. pièce No. pièce No. Bild No. pieza	No. di ordinazione Part No. No. de commande Bestell.-Nr. No. de pedido	No. pezzo No. pièce No. pièce No. Bild No. pieza	No. di ordinazione Part No. No. de commande Bestell.-Nr. No. de pedido
1	N5.1294.50	-	N1.2711.00 Δ 6205	33	N2.1016.00 \blacksquare
2	F115.4702	17	F107.3106	34	N5.0028.50 \blacksquare
3	N3.1187.00	18	N1.2711.00	35	N1.2613.50 \blacksquare DMH 2% 20x28 20
4	F105.4710	19	N1368.00 H52	36	F107.3190 \blacksquare
5	N2.6056.00	20	F107.3145	37	F107.3191 \blacksquare
6	F105.4740	21	F107.3105	38	F107.3207 \odot \blacksquare
7	N6.2166.00	22	N1.2583.00 6203	-	F107.3209 \square
8	N3.8109.00	23	N.2057.20	-	F71.1016 \circ
9	F107.3103 \odot	24	N4.4195.50	39	N1.1534.00 \circ
-	F107.3210 \square	25	N.1300.00 H40	40	F74.0811 \circ
-	F107.3358 Δ	26	F107.3206 F107.3513	41	N.1208.00 \circ
10	N1.2632.00 6004.2RS	-	F71.1011 \circ	42	F74.0810 \circ
11	N.1149.00 A20	27	N2.6056.00	43	N5.0054.00 \square
12	N4.3593.00	28	N1.4745.00	44	F118.4702
13	N1.4705.00	29	F71.1019		
14	N4.3877.00	30	F71.1018		
15	N2.6056.00	31	N4.3821.00 \odot		
16	N1.2632.00 \odot 6004.2RS	-	N4.3821.80 \square		
-	N1.2704.00 \square 6005.2RS	32	N6.3205.00		

Segnalazioni di validità
Usage code
Significations de validité
Gültigkeitsvermerk
Indicaciones de validez

\circ → 17999 \blacksquare 18000 → Δ 32337
 \odot → 22898 \square 22899 →

CODICE BARRA

FICHES



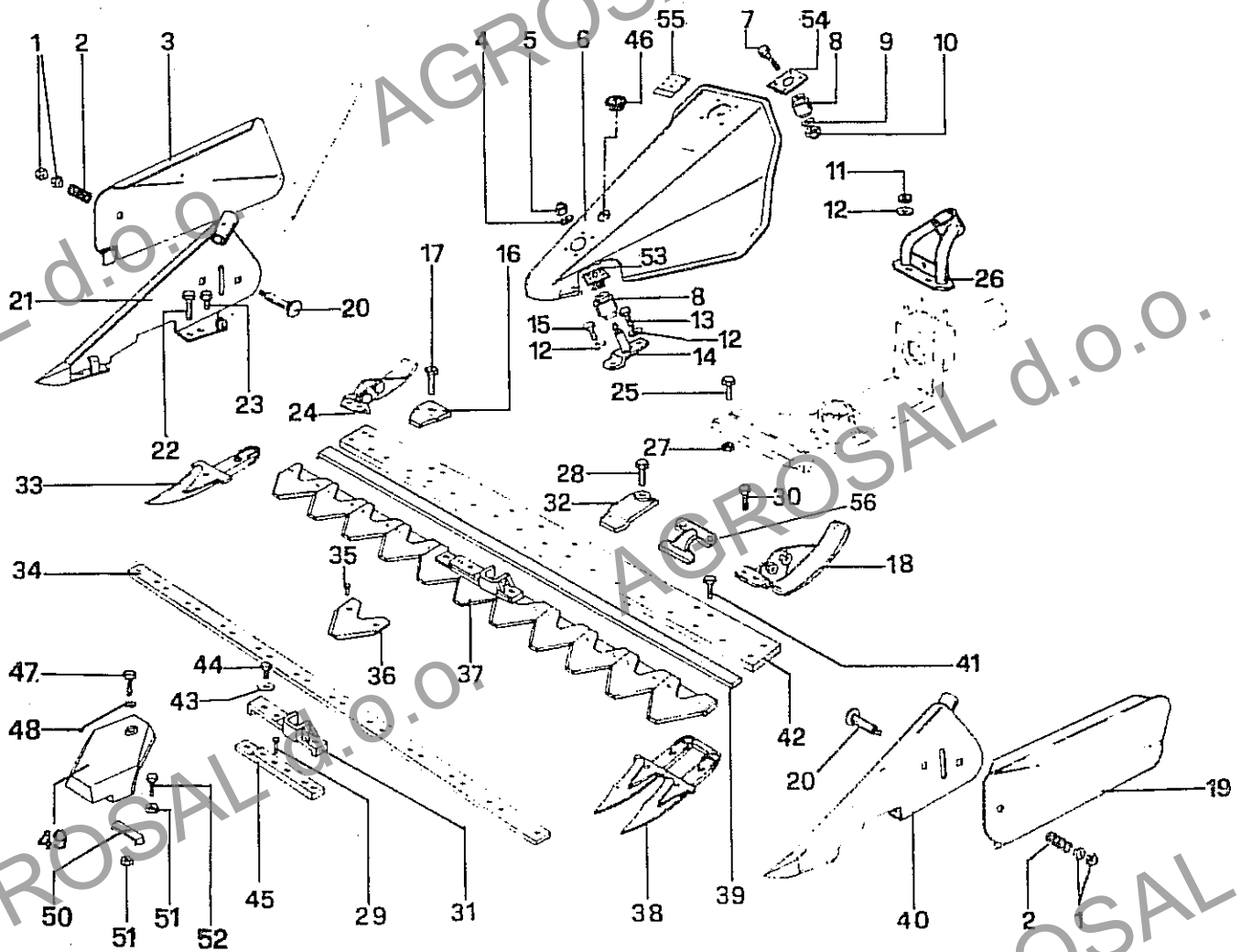

No. pezzo No. pièce No. pièce No. Bild No. pieza	No. di ordinazione Part No. No. de commande Bestell.-Nr. No. de pedido	No. pezzo No. pièce No. pièce No. Bild No. pieza	No. di ordinazione Part No. No. de commande Bestell.-Nr. No. de pedido	No. pezzo No. pièce No. pièce No. Bild No. pieza	No. di ordinazione Part No. No. de commande Bestell.-Nr. No. de pedido
1	N1.4689.00	21	F74.1609	-	F71.2027 L= 950
2	N3.1291.00	22	N6.3148.00	-	F71.2031 L=1150
3	F71.2015	23	N6.3275.00	-	F59.1593 L=1270
4	N4.3806.00	24	F107.3170	-	F107.3220 L=1450
5	N4.3812.00	25	N6.3328.00	40	F74.1635
6	N1.4638.00	26	F107.3112	41	N6.3221.00
7	F107.3144	27	N1.4638.00	42	F74.1684 L= 800
8	R107.6067	28	N6.3275.00	-	F74.1685 L= 950
9	N6.4285.00	29	N.8880.00	-	F74.1686 L=1150
10	N6.3997.10	30	N6.3149.00	-	F74.1689 L=1270
11	N4.9244.00	31	F107.3124	-	F107.3192 L=1450
12	N4.9240.00	32	F58.2686	43	N4.3666.00
13	N4.3921.50	33	F58.2738	44	N6.2457.00
14	N4.3844.10	34	F71.2006 L= 800	45	F107.3122
15	N1.4767.60	-	F71.2028 L= 950	46	N5.2612.70
16	N1.4702.00	-	F4.0411 L=1150	47	N6.2908.00
17	N1.4580.00	-	F4.0412 L=1270	48	N4.3666.00
18	N4.3667.00	-	F107.3218 L=1450	49	F105.3101
19	N6.2670.00	35	N.8866.00	50	F105.3102
20	F107.3111	36	F58.2091	51	N1.4579.00
21	F107.3215	37	F107.3126 L= 800	52	N6.2784.00
22	N6.2555.00	-	F107.3127 L= 950	53	R107.6000
23	F58.2687	-	F107.3128 L=1150	-	P898
24	N6.3275.00	-	F107.3150 L=1270	54	F107.3113
25	F107.3171	-	F107.3219 L=1450	55	N5.3921.60
26	F74.1634	38	F58.2688	56	F58.2685
27	N6.4040.00	39	F71.2008 L= 800	-	-

Segnalazioni di validità
Usage code
Signalisations de validité
Gültigkeitsvermerk
Indicaciones de validez

※ PER MOTORI DIESEL
(A RICHIESTA)

□ → 25655
■ → 25656

✚ DESTRA
✚ SINISTRA

FICHES

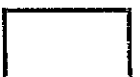

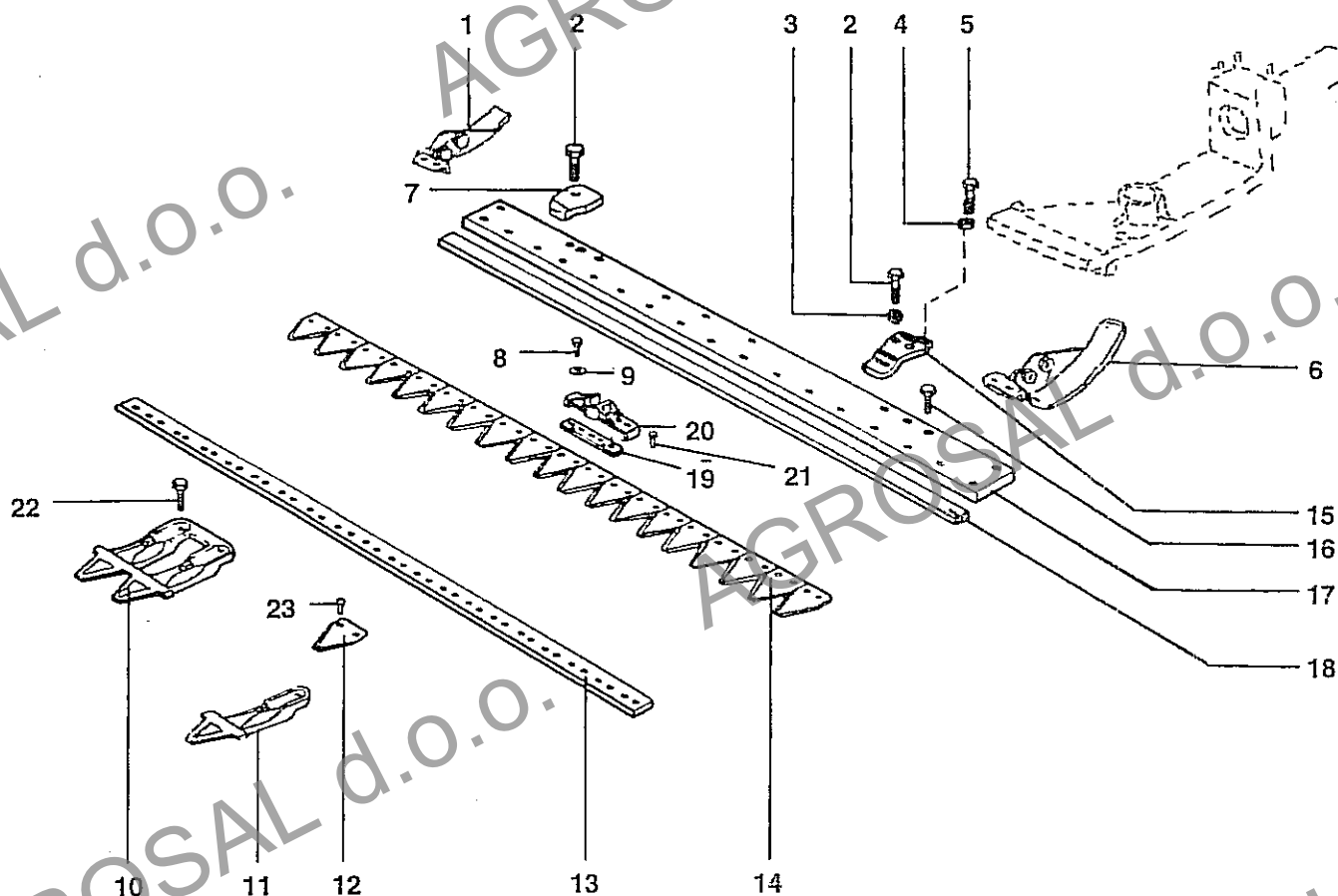

No. pezzo No. pièce No. pièce No. Bild No. pieza	No. di ordinazione Part No. No. de commande Bestell.-Nr. No. de pedido	No. pezzo No. pièce No. pièce No. Bild No. pieza	No. di ordinazione Part No. No. de commande Bestell.-Nr. No. de pedido	No. pezzo No. pièce No. pièce No. Bild No. pieza	No. di ordinazione Part No. No. de commande Bestell.-Nr. No. de pedido
1	F107.3170	-	F107.3216	-	F71.2027 L= 950
2	N6.3333.00	13	F107.3125 L=1150	-	F59.1593 L=1270
-	N6.2457.00 tipo doppio	-	F74.1628 L= 950	-	F107.3193 L=1450
3	F107.3119	-	F107.3154 L=1270	19	F107.3123
4	N1.4628.00	-	F107.3137 L=1150	20	F107.3124
5	N6.3153.00	14	F107.3216	21	N8880.00
6	F107.3171	-	F107.3136 L= 950	22.	N6.3253.00
7	F58.2687	-	F107.3152 L=1270	23	N8866.00
8	N6.2457.00	-	F107.3194 L=1450		
9	N4.3666.00	-	F107.3118		
10	F111.3114	15	F111.3112 tipo doppio		
11	F111.3113	-	N6.3149.00		
12	F74.1683	16	F74.1686 L=1150		
-	F107.3216	17	F74.1685 L= 950		
-	F74.1683	-	F74.1689 L=1270		
-	F107.3216	-	F107.3192 L=1450		
-	F74.1683	18	F71.2031 L=1150		

Segnalazioni di validità
Usage code
Signalisations de validité
Gültigkeitsvermerk
Indicaciones de validez

cm. 115 cm. 127 23368 25605 25781
 cm. 145 cm. 95 23369 25606 25782

FICHES



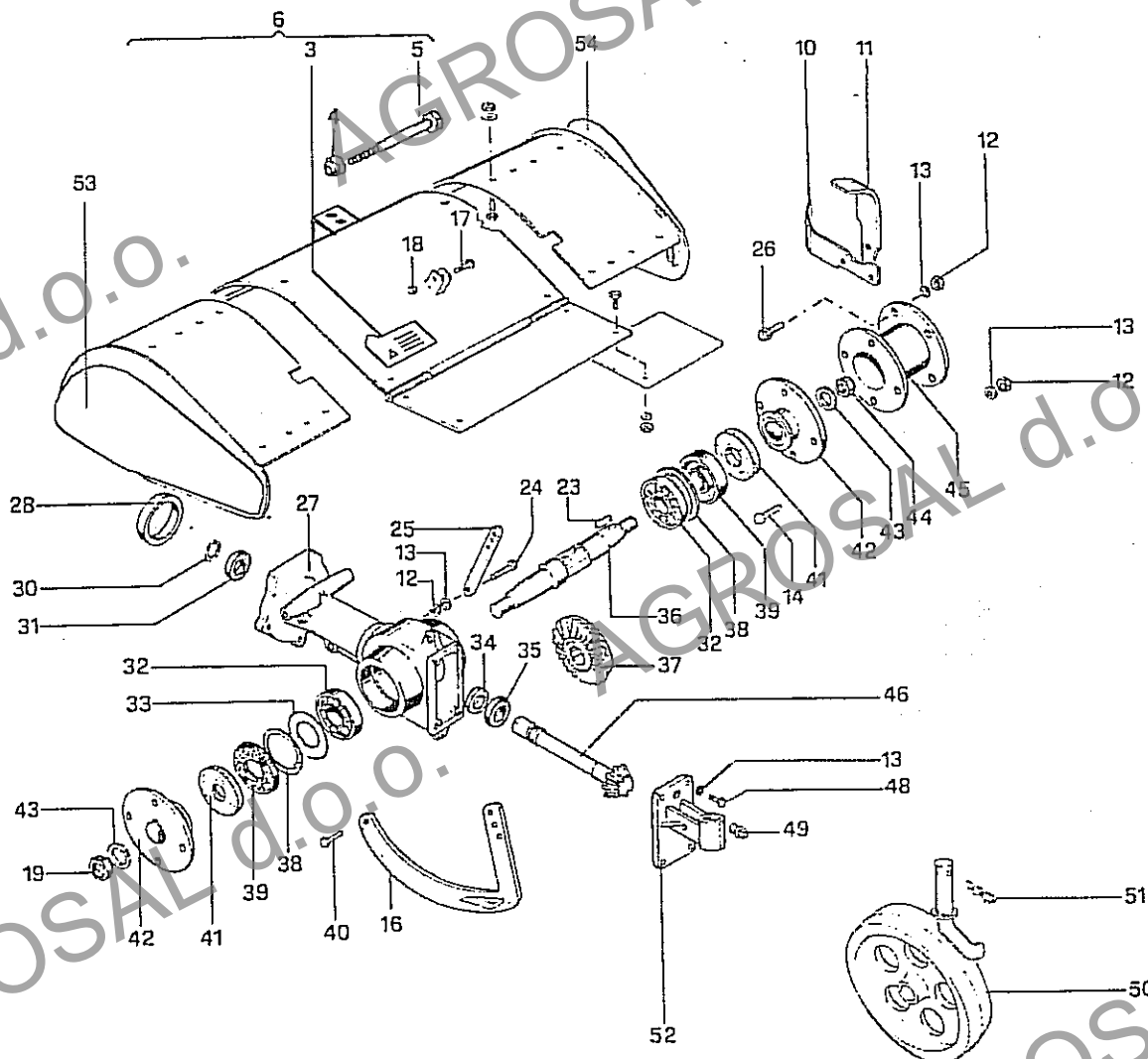

No. pezzo No. pièce No. pièce No. Bild No. pieza	No. di ordinazione Part No. No. de commande Bestell.-Nr. No. de pedido	No. pezzo No. pièce No. pièce No. Bild No. pieza	No. di ordinazione Part No. No. de commande Bestell.-Nr. No. de pedido	No. pezzo No. pièce No. pièce No. Bild No. pieza	No. di ordinazione Part No. No. de commande Bestell.-Nr. No. de pedido
3	F1.5577	30	N.1149.00 A20	48	N6.2554.00
4	N1.4767.60	31	N1.2632.00 6004.2R5	49	N5.2540.00
5	N6.4337.70	32	N1.2707.00 b205	50	F67.1403
6	F1.5527	33	N5.0088.00	51	N5.1497.00
10	F1.5517 ↕	34	N.2074.00 OK20x35x10	52	F1.5540
11	F1.5518 ↕	35	N1.2640.51	53	F1.5574
12	N1.4573.00	36	F1.3531	54	F1.5573
13	N4.3666.00	37	F1.5503 <input type="checkbox"/>		
14	N6.2740.00	-	F1.5582 <input checked="" type="checkbox"/>		
16	F1.5548	38	N.1368.00 H52		
17	N6.2670.00	39	N.2100.50 OK25x52x7		
18	N1.4574.00	40	N6.2669.00		
19	N1.4826.00 ↕	41	F1.3525		
23	N.6522.00	42	F1.5510		
24	N6.2723.00	43	N4.4180.00		
25	F1.3514	44	N1.4825.00 ↕		
26	N6.2622.00	45	F1.5515		
27	F1.5512	46	F1.5502 <input type="checkbox"/>		
28	F1.3529	-	F1.5581 <input checked="" type="checkbox"/>		

Segnalazioni di validità
Usage code
Signalisations de validité
Gültigkeitsvermerk
Indicaciones de validez

↕ DESTRA
↕ SINISTRA

Z= 9/28 m= 3,25
 Z= 7/22 m= 4,25

FICHES



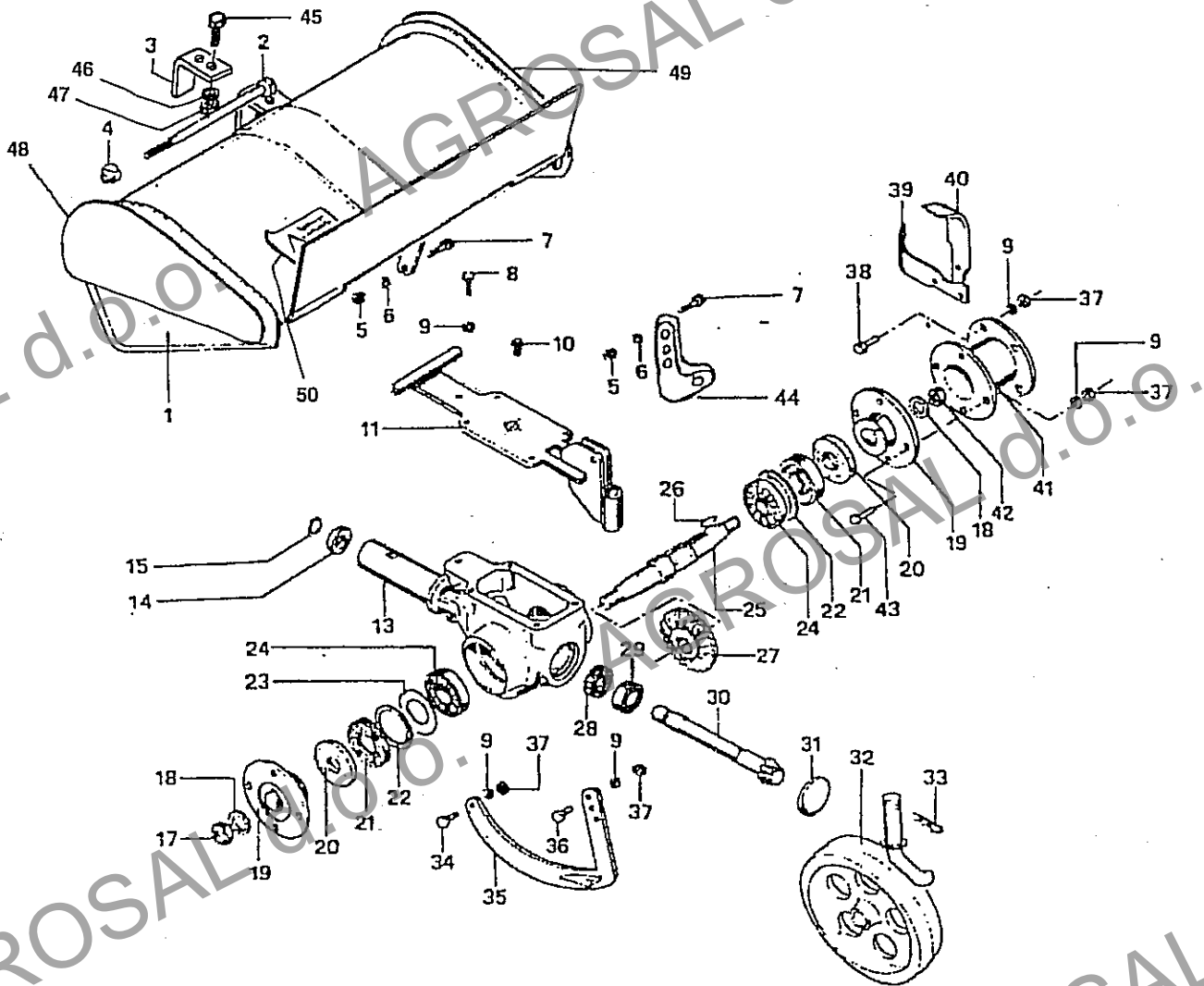

No. pezzo No. pièce No. de commande No. Bild No. pieza	No. di ordinazione Part No. No. de commande Bestell.-Nr. No. de pedido	No. pezzo No. pièce No. de commande No. Bild No. pieza	No. di ordinazione Part No. No. de commande Bestell.-Nr. No. de pedido	No. pezzo No. pièce No. de commande No. Bild No. pieza	No. di ordinazione Part No. No. de commande Bestell.-Nr. No. de pedido
1	F1.5527	21	N.2100.50 0425x52x7	38	N6.2621.00
2	N6.4337.70	22	N.1368.00 H52	39	F1.5517
3	F01.5572	23	N5.0068.00	40	F1.5518
-	F01.5578 *	24	N1.2707.00 b205	41	F1.5515
4	N1.4767.60	25	F1.3531	42	N1.4825.00
5	N1.4574.00	26	N.6522.00	43	N6.2740.00
6	N4.3667.00	27	F1.5503 <input type="checkbox"/>	44	F1.5552
7	N6.2670.00	-	F1.5582 <input checked="" type="checkbox"/>	45	N6.2488.00
8	N6.2554.00	28	N.2074.00 0420x35x10	46	N4.3685.00
9	N4.3666.00	29	N1.2640.50 3204	47	N1.4574.00
10	N5.2540.00	30	F1.5544 <input type="checkbox"/>	48	F01.5574
11	F1.5542	-	F1.5583 <input checked="" type="checkbox"/>	49	F01.5573
13	F1.5541	31	N5.2767.00	50	F01.5577
14	N1.2632.00 6004.2R5	32	F67.1403		
15	N.1149.00 A20	33	N5.1497.00		
17	N1.4826.00	34	N6.2669.00		
18	N4.4180.00	35	F1.5548		
19	F1.5547	36	N6.2669.00		
20	F1.3525	37	N1.4573.00		

Segnalazioni di validità
Usage code
Signalisations de validité
Gültigkeitsvermerk
Indicaciones de validez

DESTRA
 SINISTRA
* OMOL. GS

Z= 9/28 m= 3,25
 Z= 7/22 m= 4,25

FICHES

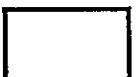

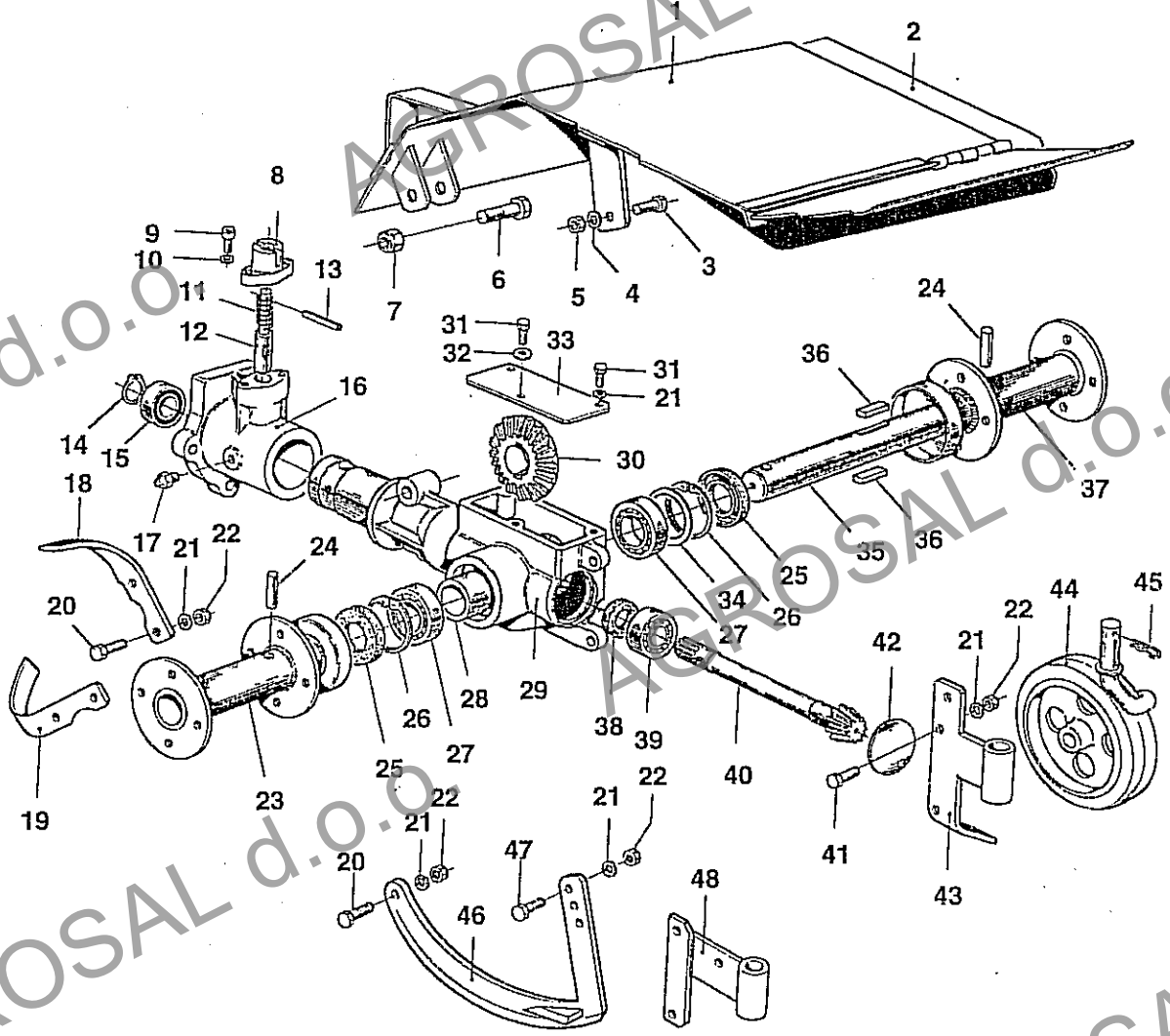

No. pezzo No. pièce No. pièce No. Bild No. pieza	No. di ordinazione Part No. No. de commande Bestell.-Nr. No. de pedido	No. pezzo No. pièce No. pièce No. Bild No. pieza	No. di ordinazione Part No. No. de commande Bestell.-Nr. No. de pedido	No. pezzo No. pièce No. pièce No. Bild No. pieza	No. di ordinazione Part No. No. de commande Bestell.-Nr. No. de pedido
1	F01.7001 ▼	18	F01.7003	35	F01.7016
-	F01.7012 ▲	19	F01.7002	36	N.6517.00
2	F01.7020 ↘	20	N6.2723.00	-	N.6516.10 □
-	F01.7021 ↙	21	N4.3666.00	37	F01.7005
3	N6.2670.00	22	N1.4573.00	-	F01.7011 ★★
4	N4.3667.00	23	F01.7005	38	N.2073.00 Øk 20x35x7
5	N1.4574.00	-	F01.7011 ★★	39	N1.2637.01
6	N6.3951.00	24	N5.1431.00	40	F01.7008
7	N1.4701.50	25	N.2124.50 Øk 30x55x10	41	N6.2669.00
8	F115.4702	26	N.1380.00 H55	42	N5.2767.00
9	N6.2166.00	27	N1.2745.00 boob	43	F01.7006 ▼
10	N4.3591.10	28	F01.7018	44	F67.1403 ★
11	N3.1187.00	29	F01.7000	45	N5.1497.00 ★
12	F105.4710	30	F01.7017	46	F01.5548 ▲
13	N5.1294.50	31	N6.2493.00	47	N6.2741.00 ▲
14	N.1149.00 A20	32	N4.3647.00	48	F01.7019 ▲
15	N1.2632.00 booy. 2 R5	33	F01.7009		
16	F01.7010	34	N5.0093.20 ○		
17	N2.6056.00	-	N5.0093.30 ●		

Segnalazioni di validità
Usage code
Signalisations de validité
Gültigkeitsvermerk
Indicaciones de validez

↘ destra ▼ cofano fisso ○ spessore 0,2 ★ a richiesta
 ↙ sinistra ▲ cofano registrabile ● spessore 0,3 ★★ a richiesta per L=350
 □ Linguetta con estremità arrotondate

FICHES

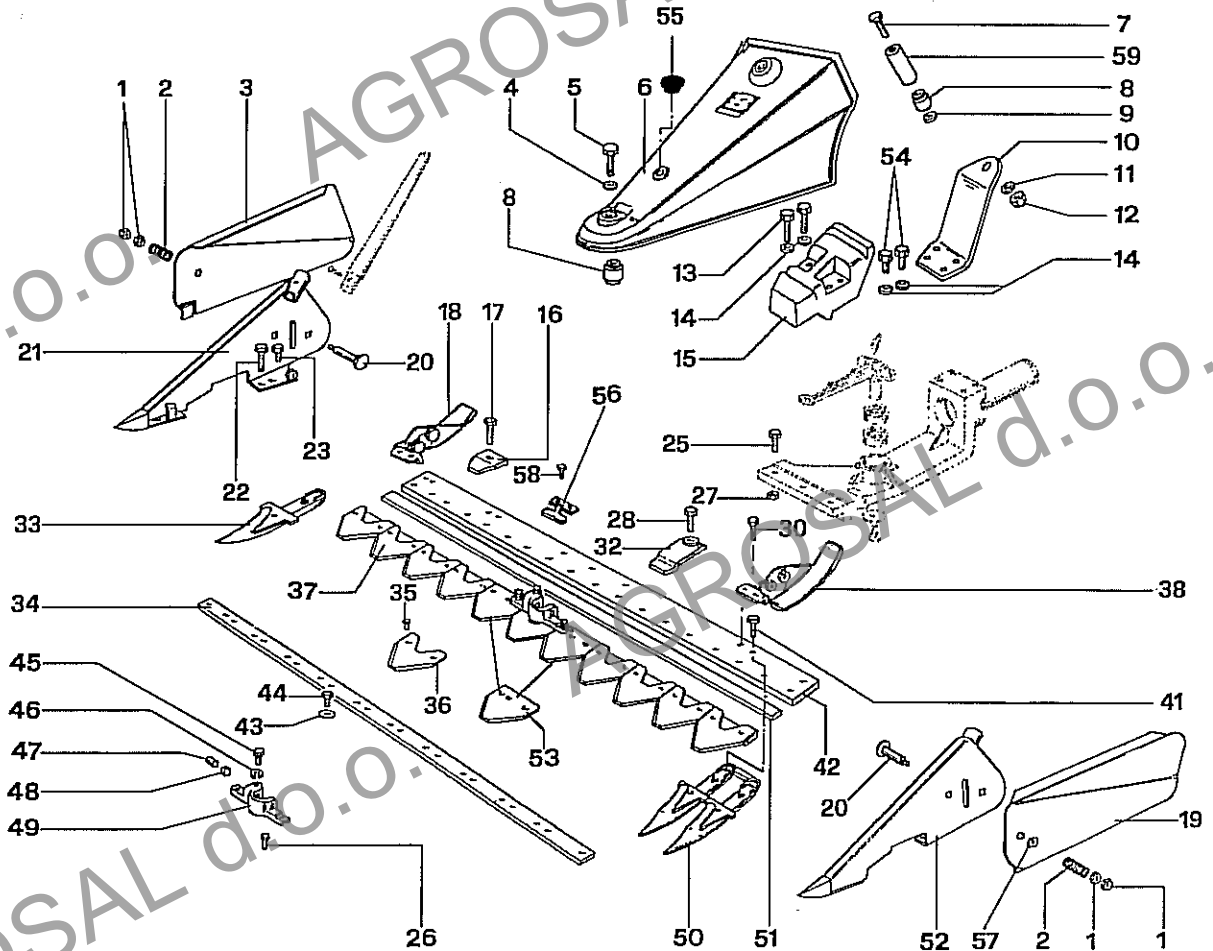

No. pezzo No. pièce No. pièce No. Bild No. pieza	No. di ordinazione Part No. No. de commande Bestell. - Nr. No. de pedido	No. pezzo No. pièce No. pièce No. Bild No. pieza	No. di ordinazione Part No. No. de commande Bestell. - Nr. No. de pedido	No. pezzo No. pièce No. pièce No. Bild No. pieza	No. di ordinazione Part No. No. de commande Bestell. - Nr. No. de pedido
1	N1.4689.00	25	N6.3328.00	43	N4.3367.00
2	N3.1219.00	26	107.3261	44	N6.2488.00
3	71.2615	-	107.3399 +	45	N6.2622.00
4	N4.3844.10	27	N1.4636.00	46	N4.3667.00
5	N6.3997.10	28	N6.3314.00	47	N6.4339.00
6	107.3345	30	N6.3149.00	48	107.3364
7	N6.3997.10	32	58.2686	49	107.3363 X barra spec.
-	N6.4065.00 □	33	58.2738	-	107.3376 X barra senif.
8	4.9240.00	34	107.3379 950SF	50	58.2688
9	N4.3844.10	-	107.3380 1150SF	51	71.2027 950
10	107.3346	-	107.3381 1270SF	-	71.2031 1150
11	N4.3844.10	-	107.3382 1450SF	-	59.1593 1270
12	N1.4702.00	35	N8866.00	-	107.3220 1450
13	N6.2944.00	36	58.2091	52	74.1635
14	N4.3667.00	37	107.3383 950SF	53	107.3377 destro
15	107.3397	-	107.3384 1150SF	-	107.3378 sinistro
16	58.2687	-	107.3385 1270SF	54	N6.2488.00
17	N6.3328.00	-	107.3386 1450SF	55	N5.2659.00
18	107.3170	38	107.3171	56	58.2685
19	74.1634	41	N6.3254.00	57	N4.3377.00
20	N6.4040.00	42	74.1685 950	58	N6.3314.00
21	74.1609	-	74.1686 1150	59	107.3465 □
22	N6.3276.00	-	74.1689 1270		
23	N6.3149.00	-	107.3382 1450		

Segnalazioni di validità
Usage code
Signalisations de validité
Gültigkeitsvermerk
Indicaciones de validez

✦ ESM □ con macchine che montano gancio di traino F121.2107

FICHES



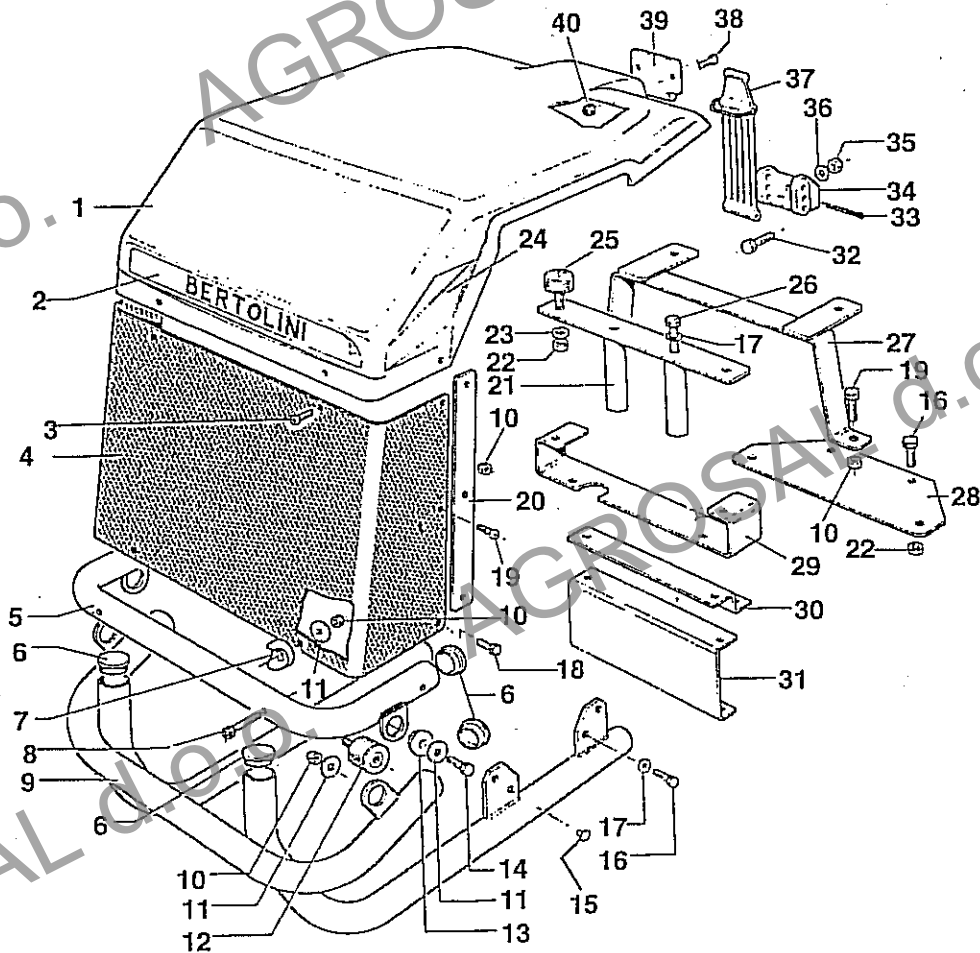

No. pezzo No. pièce No. pièce No. Bild No. pieza	No. di ordinazione Part No. No. de commande Bestell. - Nr. No. de pedido	No. pezzo No. pièce No. pièce No. Bild No. pieza	No. di ordinazione Part No. No. de commande Bestell. - Nr. No. de pedido	No. pezzo No. pièce No. pièce No. Bild No. pieza	No. di ordinazione Part No. No. de commande Bestell. - Nr. No. de pedido
1	F120.2103 ●	14	N6.2097.10.	31	F120.2116 (ALN 330) □
-	F120.2119 ○	15	N5.2524.20	32	N6.2555.00
2	F109.2124	16	N6.2486.00	33	N1.0608.00
-	N5.3813.00 ※	17	N4.3649.00	34	F120.2123
3	N6.2097.10	18	N6.2345.00	35	N1.4585.00
4	F109.2117 ○	19	N6.1998.00	36	N4.3694.00
-	F109.2118 ●	20	F120.2113 ●	37	F120.2124
5	F120.2104 ●	-	F120.2114 ○	38	N6.1929.80
-	F120.2112 ○	21	F120.2107 (6LD 360)	39	F120.2127
6	N5.2674.00	22	N1.4574.00	40	N1.4529.80
7	F120.2109	23	N4.3667.00		
8	N6.2400.00	24	F121.2103 ✎		
9	F120.2106 (6LD 360)	-	F121.2104 ✎		
-	F120.2110 (MC71)	25	N4.9206.13		
-	F120.2111 ○	26	N6.3079.00		
10	N1.4547.00	27	F120.2115 (IM 300/350)		
11	N4.3622.00	28	F120.2120 (MC71)		
12	N4.9205.50	29	F120.2118 (CA 340)		
13	F75.2170	30	F120.2117 (ALN 330)		

Segnalazioni di validità
 Usage code
 Signalfications de validité
 Gültigkeitsvermerk
 Indicações de validez

● Per motori diesel
 ○ Per motori benzina
 ※ GEMAC

✎ destra
 ✎ sinistra

□ con serbatoio in lamiera

FICHES



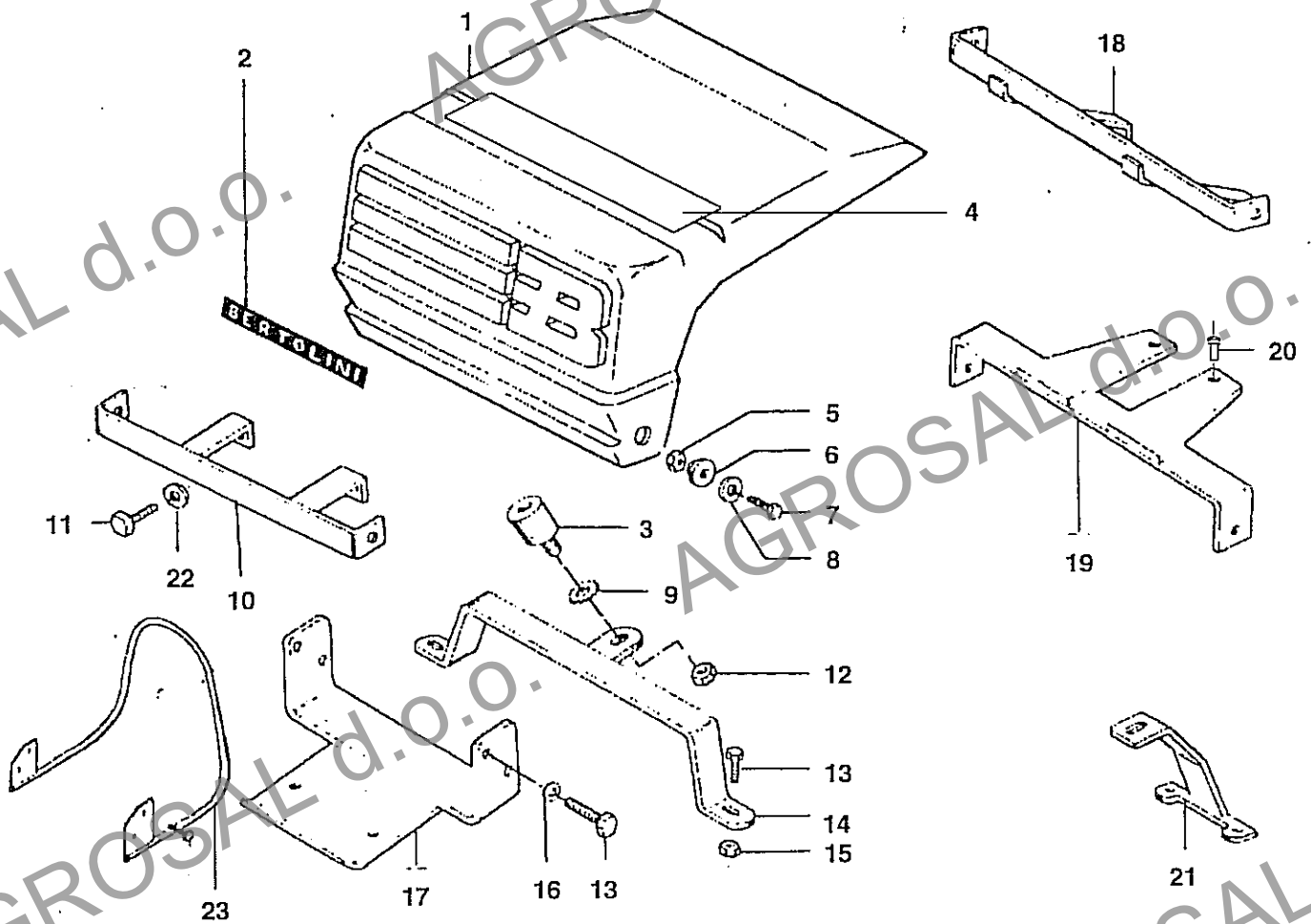

No. pezzo No. pièce No. pièce No. Bild No. pieza	No. di ordinazione Part No. No. de commande Bestell. - Nr. No. de pedido	No. pezzo No. pièce No. pièce No. Bild No. pieza	No. di ordinazione Part No. No. de commande Bestell. - Nr. No. de pedido	No. pezzo No. pièce No. pièce No. Bild No. pieza	No. di ordinazione Part No. No. de commande Bestell. - Nr. No. de pedido
1	F105.2112 ▲▲▲	15	N1.4547.00 ▲		
-	F105.2114 ▼	-	N1.4585.00 ▼		
2	F105.2116	16	N4.3649.00		
3	F75.2159	17	F105.2119 ▲		
4	F121.2102	18	F105.2118 ▲		
5	N1.4547.00	19	F75.2164 ▲		
6	F75.2170	20	N6.1293.50 ▲		
7	N6.2210.00	21	F75.2165 ▲		
8	N4.3622.00	22	N4.3667.00 ▼▲		
9	N4.3667.00	23	F109.2102 ▲▼		
10	F75.2162 ▲▲	-	F120.2102 ▲		
-	F105.2120 ▼				
11	N6.2108.00 ▲				
-	N6.2555.00 ▼				
12	N1.4574.00				
13	N6.2047.00 ▲				
-	N6.2488.00 ▼				
14	F75.2163 ▲				
-	F105.2121 ▼				

Segnalazioni di validità
Usage code
Significations de validité
Gültigkeitsvermerk
Indicaciones de validez

▼ MC 71
▲ 6 LD 360

▲ 1 IM 300
▲ 1 IM 350
▲ ALN 330 W
▲ CA 340

FICHES

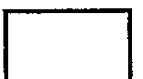

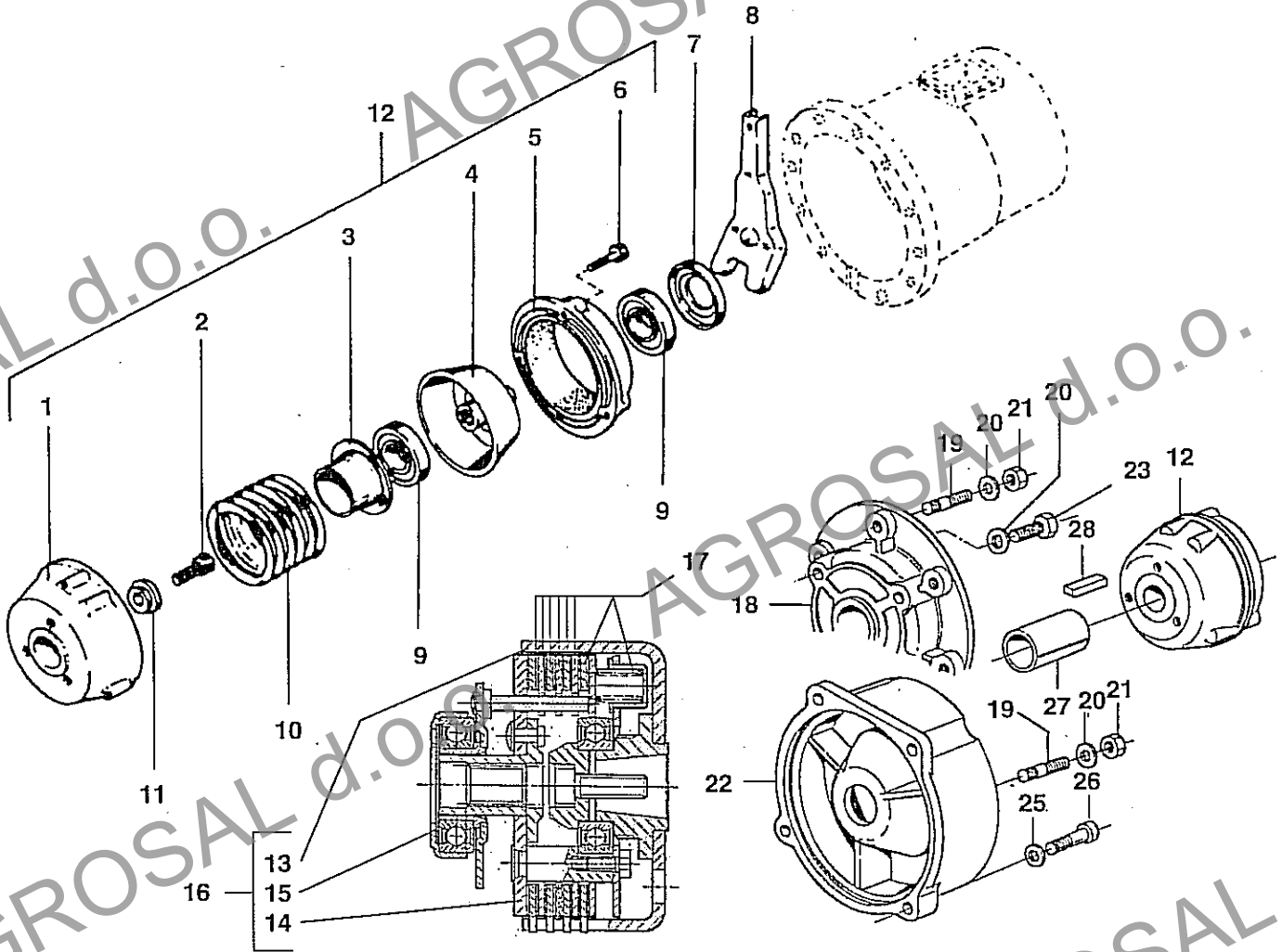

No. pezzo No. pièce No. pièce No. Bild No. pieza	No. di ordinazione Part No. No. de commande Bestell. - Nr. No. de pedido	No. pezzo No. pièce No. pièce No. Bild No. pieza	No. di ordinazione Part No. No. de commande Bestell. - Nr. No. de pedido	No. pezzo No. pièce No. pièce No. Bild No. pieza	No. di ordinazione Part No. No. de commande Bestell. - Nr. No. de pedido
1	F75.0001	-	P1008 ○		
-	F105.0029 ○	-	P1009 ●		
-	F105.0032 ●	13	F109.0003		
2	N6.2892.00 △	14	F109.0004		
-	N6.2680.00 ▲▼	15	F109.0005		
-	N6.2439.50 ○	16	F109.0002		
-	N6.3670.10 ●	17	F109.0006		
3	F105.0005	18	F105.0027		
4	F105.0006	19	N3.8125.00		
5	F75.0004	20	N4.3654.00		
6	N6.2348.00	21	N1.4574.00		
7	F75.0014	22	F105.0031		
8	F75.0011	23	N6.2439.80		
9	N1.2632.01	25	N4.3764.00		
10	N3.1381.86	26	N6.3097.90		
11	F105.0003	27	F105.0028 ○		
-	F105.0033 ●	-	F105.0030 ●		
12	P443 ▲▼	28	N.6434.10 ○		
-	P863 △	-	N.6480.80 ●		

Segnalazioni di validità
Usage code
Signalisations de validité
Gulligkeitsvermerk
Indicaciones de validez

▲ 6 LD 360
MC 71

▼ IM 300
IM 350
CA 340

△ ALN 330

○ HONDA GX 140
B. & STRATTON

● HONDA GX 240
B. & STRATTON

FICHES



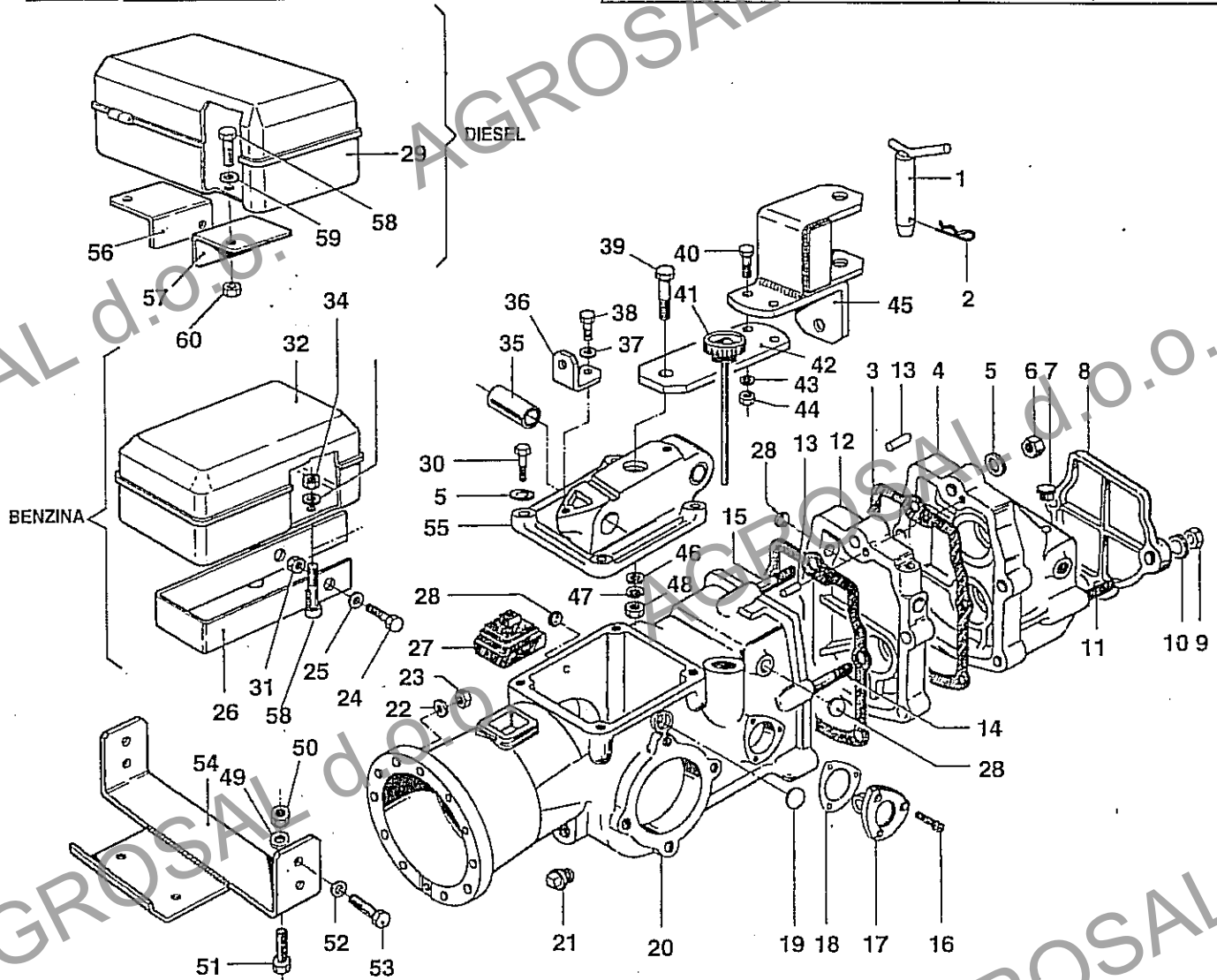

No. pezzo No. pièce No. pièce No. Bild No. pieza	No. di ordinazione Part No. No. de commande Bestell. - Nr. No. de pedido	No. pezzo No. pièce No. pièce No. Bild No. pieza	No. di ordinazione Part No. No. de commande Bestell. - Nr. No. de pedido	No. pezzo No. pièce No. pièce No. Bild No. pieza	No. di ordinazione Part No. No. de commande Bestell. - Nr. No. de pedido
1	F75.1647	21	N5.2540.00	45	F118.4701
2	N5.1488.00	22	N4.3672.00	46	N4.3844.00
3	F105.0822	23	N1.4574.00	47	N4.3905.00
4	F105.0834	24	N6.2488.00	48	N1.4695.00
5	N4.3763.00	25	N4.3649.00	49	N1.4574.00 ○
6	N1.4620.00	26	F118.2104	-	N1.4632.00 ●
7	F75.0835	27	F75.1646	50	N4.3654.00 ○
8	F105.0833	28	N5.2562.00	-	N4.3764.00 ●
9	N1.4705.00	29	F120.2125	51	N6.2741.00 ○
10	N4.3877.00	30	N6.3275.00	-	N6.3328.00 ●
11	N3.8615.00	31	N1.4574.00	52	N4.3649.00
12	F109.0803	32	F118.2105	53	N6.2488.00
13	N5.1289.00 ■	34	N1.4574.00	54	F105.2122 *
-	N5.1243.00 □	35	N4.9247.00	-	F105.2126 ○★
14	N3.8451.00 ■	36	F107.1617	-	F105.2104 ●★
-	N3.8464.00 ■	37	N4.3667.00	-	F120.2102 ◆
-	N3.8424.00 □	38	N6.2621.00	55	F107.0801
15	N3.8470.00	39	N6.4066.00	56	F118.2101
16	N6.2108.00	40	N6.3254.00	57	F118.2102
17	F109.0816	41	N5.3506.00	58	N6.2097.10
18	F105.0827	42	F121.2101	59	N4.3622.00
19	N5.2613.00	43	N4.3799.00	60	N1.4547.00
20	F105.0801	44	N1.4632.00		

Segnalazioni di validità
Usage code
Signalisations de validité
Gültigkeitsvermerk
Indicaciones de validez

◆ motori benzina
* A 220

○ HONDA GX 140
● HONDA GX 240
★ B. & STRATTON

□ → 1885
■ 1886 →

☞ destra
☜ sinistra

FICHES



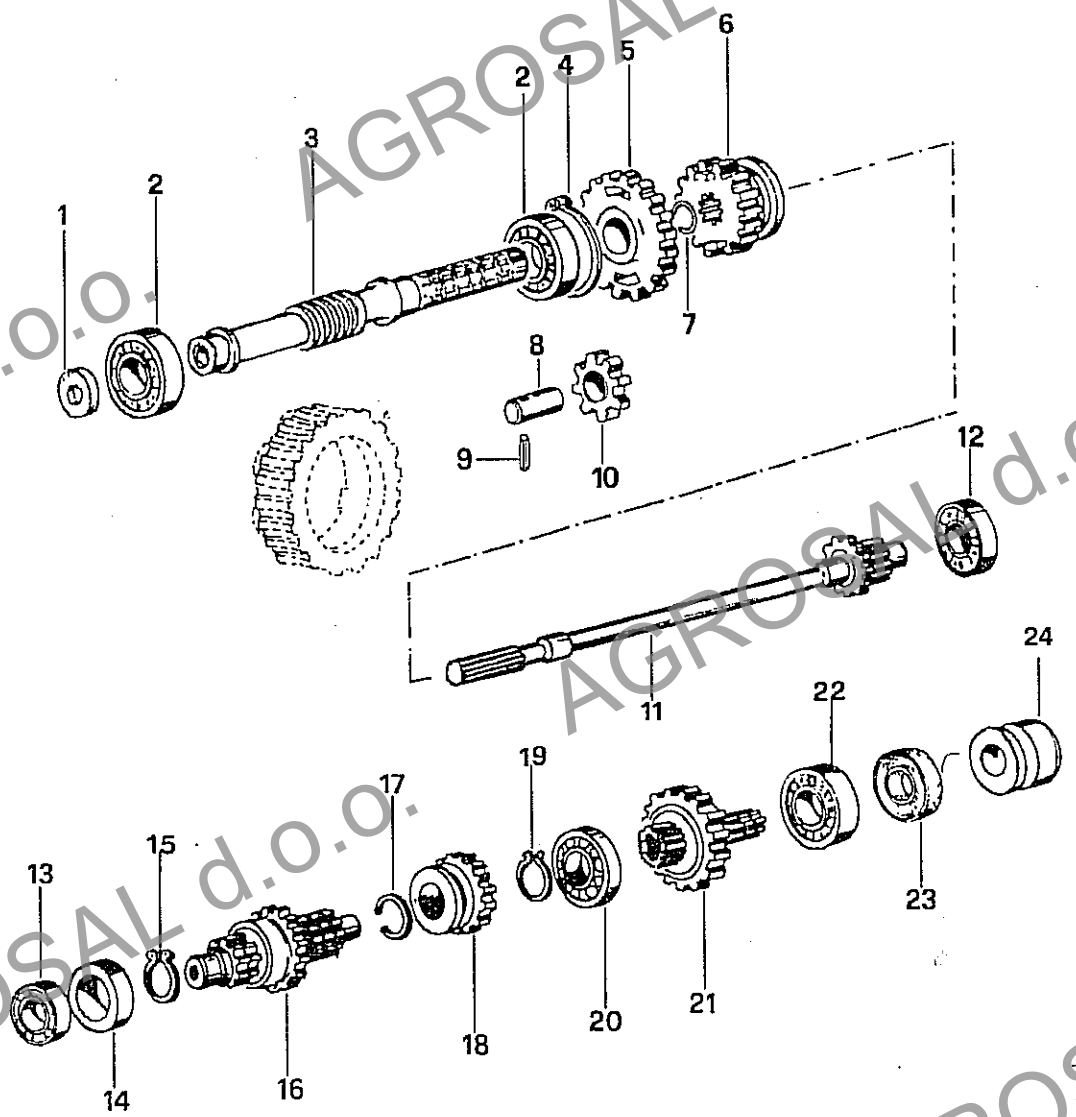

No. pezzo No. pièce No. pièce No. Bild No. pieza	No. di ordinazione Part No. No. de commande Bestell. - Nr. No. de pedido	No. pezzo No. pièce No. pièce No. Bild No. pieza	No. di ordinazione Part No. No. de commande Bestell. - Nr. No. de pedido	No. pezzo No. pièce No. pièce No. Bild No. pieza	No. di ordinazione Part No. No. de commande Bestell. - Nr. No. de pedido
1	N. 2047.50 45K ok 15K267	20	N1.2695.00 16005		
2	N1.2707.00 6205	21	F109.0813		
3	F109.0802	22	N1.2698.00 6005		
4	N.1368.00 A52	23	N.2073.00 ok 20K35X7		
5	F109.0806	24	F105.0839		
6	F109.0805				
7	N.0046.50				
8	F105.0826				
9	N5.1014.50				
10	F109.0815				
11	F109.0804				
12	N1.2637.00 6204				
13	N1.2570.00 6202				
14	F109.0817				
15	N.1200.00 A27				
16	F116.0804				
17	N.0046.50				
18	F109.0810				
19	N.1174.00 A24				

Segnalazioni di validità
Usage code
Signalisations de validité
Gültigkeitsvermerk
Indicaciones de validez

FICHES



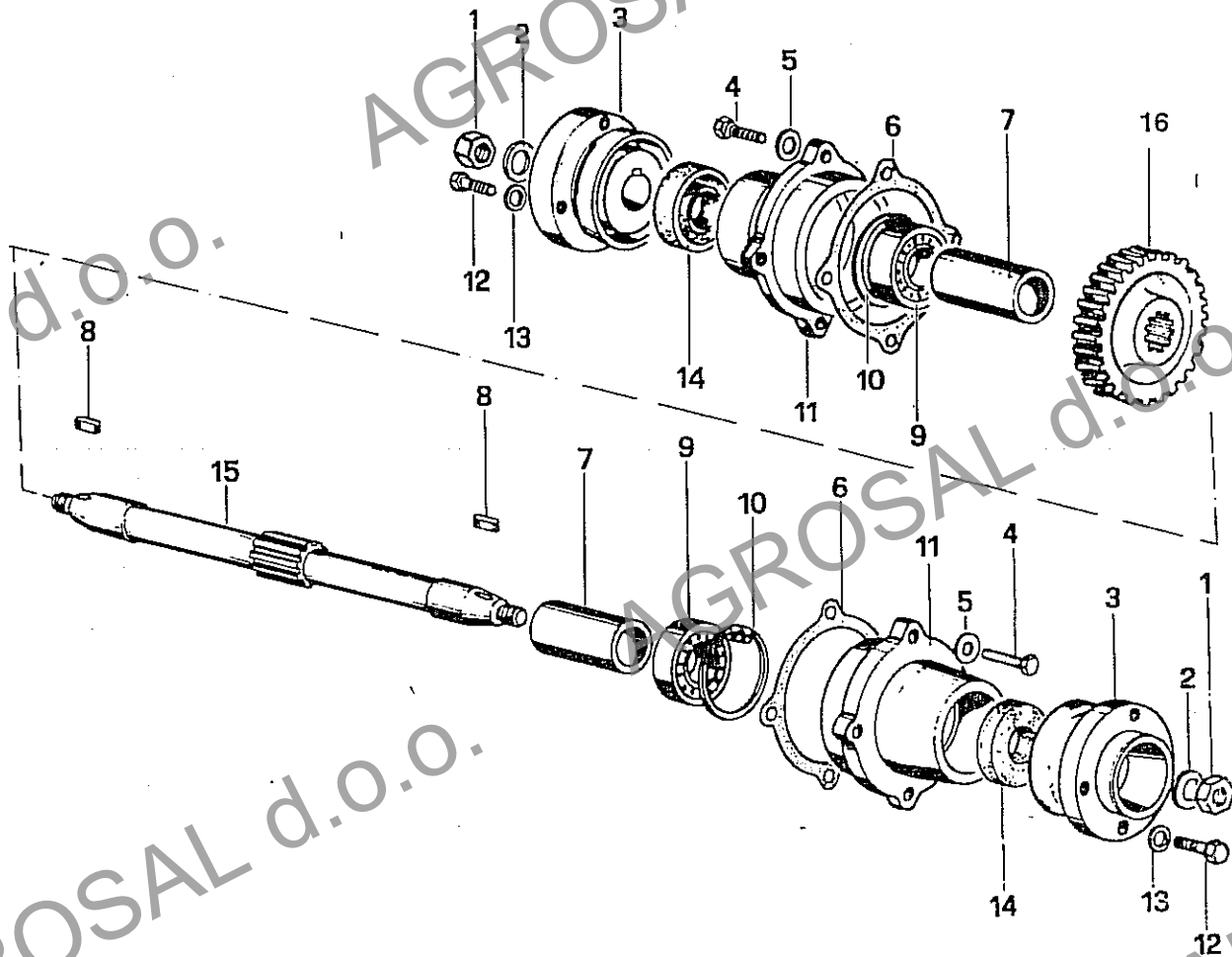

No. pezzo No. pièce No. pièce No. Bild No. pieza	No. di ordinazione Part No. No. de commande Bestell.-Nr. No. de pedido	No. pezzo No. pièce No. pièce No. Bild No. pieza	No. di ordinazione Part No. No. de commande Bestell.-Nr. No. de pedido	No. pezzo No. pièce No. pièce No. Bild No. pieza	No. di ordinazione Part No. No. de commande Bestell.-Nr. No. de pedido
1	N1.4798.00				
2	N4.4030.00				
3	F105.0223				
4	N6.2669.00				
5	N4.3649.00				
6	F105.0202				
7	F105.0205				
8	N.6468.00				
9	N1.2707.00 6205				
10	N.1368.00 H52				
11	F105.0201				
12	N6.3220.00				
13	N4.3799.00				
14	N.2100.50 OK 25x52x7				
15	F105.0203				
16	F109.0217				

Segnalazioni di validità
Usage code
Signalisations de validité
Gültigkeitsvermerk
Indicaciones de validez

FICHES

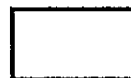

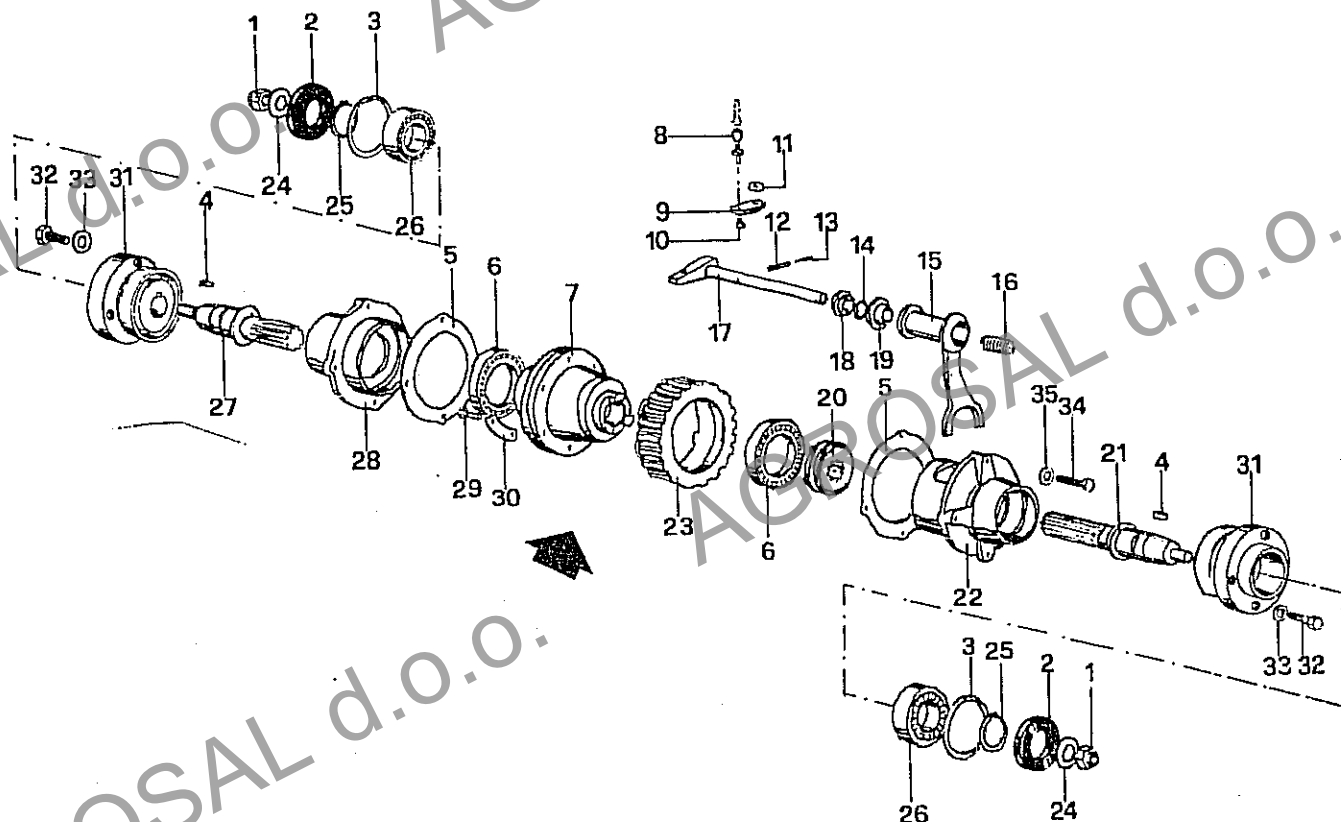

No. pezzo No. pièce No. pièce No. Bild No. pieza	No. di ordinazione Part No. No. de commande Bestell. - Nr. No. de pedido	No. pezzo No. pièce No. pièce No. Bild No. pieza	No. di ordinazione Part No. No. de commande Bestell. - Nr. No. de pedido	No. pezzo No. pièce No. pièce No. Bild No. pieza	No. di ordinazione Part No. No. de commande Bestell. - Nr. No. de pedido
1	N1.4798.00	20	F105.0212		
2	N2100.50 0H25x52x7	21	F105.0210		
3	N1368.00 H52	22	F105.0207		
4	N6468.00	23	F109.0201		
5	F105.0202	24	N4.4030.00		
6	N1.2891.00 16008	25	N1185.00 A25		
7	F105.0211	26	N1.2707.01 6205		
8	N5.8010.00	27	F105.0209		
9	F105.642	28	F105.0206		
10	N5.9016.00	29	N6.2545.00		
11	N4.3798.00	30	F105.0213		
12	N5.1191.00	31	F105.0223		
13	N5.1055.00	32	N6.3220.00		
14	N3176.00	33	N4.3799.00		
15	F105.1654	34	N6.2669.00		
16	N3.1195.60	35	N4.3649.00		
17	F105.1631				
18	F105.1625				
19	F105.1649				

Segnalazioni di validità
Usage code
Signalisations de validité
Gültigkeitsvermerk
Indicaciones de validez

FICHES

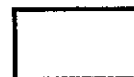

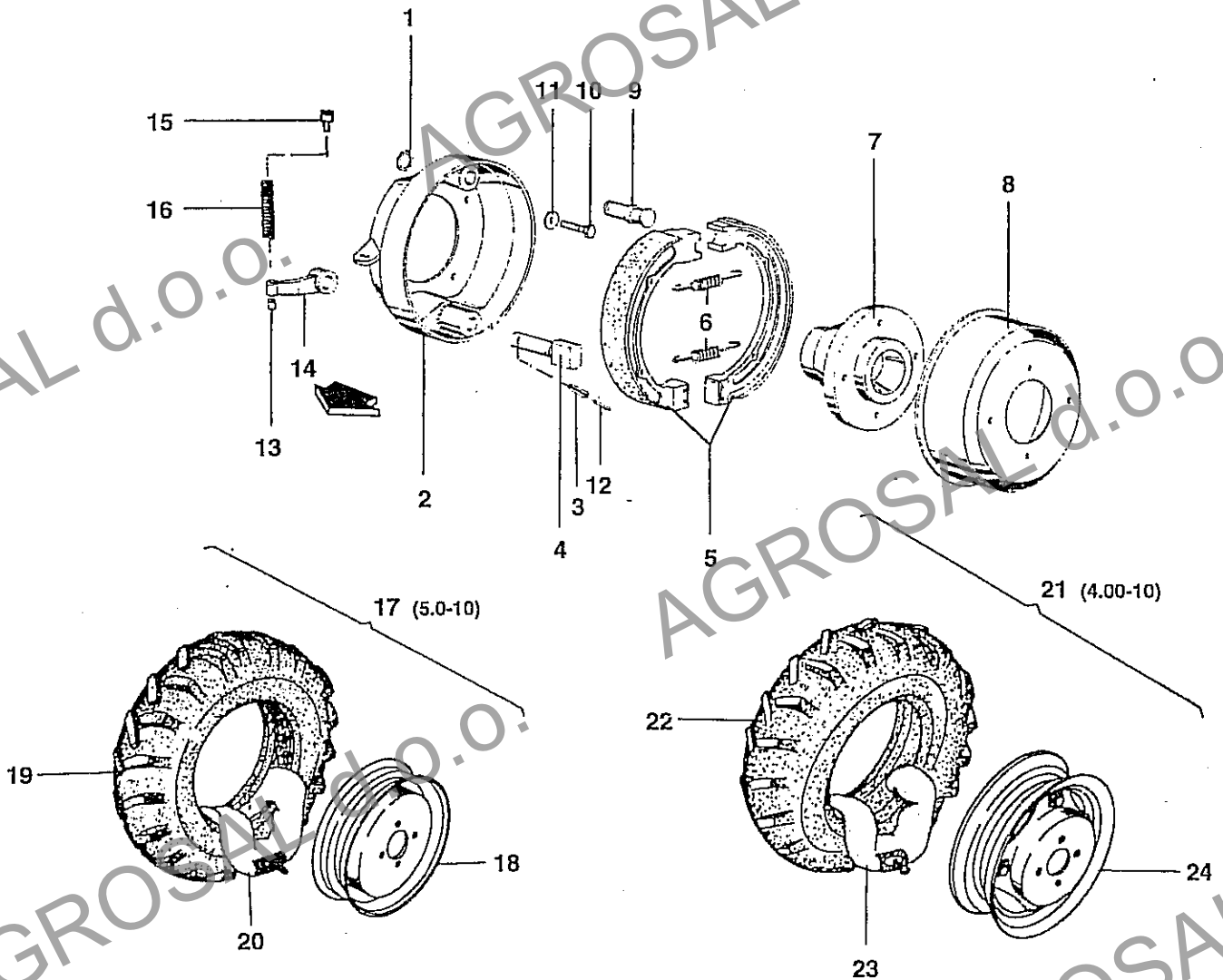

No. pezzo No. pièce No. pièce No. Bild No. pieza	No. di ordinazione Part No. No. de commande Bestell. - Nr. No. de pedido	No. pezzo No. pièce No. pièce No. Bild No. pieza	No. di ordinazione Part No. No. de commande Bestell. - Nr. No. de pedido	No. pezzo No. pièce No. pièce No. Bild No. pieza	No. di ordinazione Part No. No. de commande Bestell. - Nr. No. de pedido
1	N.1072.00	17	P.860		
2	F105.0217	18	N4.9015.90		
-	F105.0218	19	N4.8535.00		
3	N5.1173.00	20	N4.8825.00		
4	F105.0221	21	P.605		
-	F105.0220	22	N4.8520.00		
5	N2.3627.00	23	N4.8815.00		
6	N3.1051.00	24	N4.9015.90		
7	F105.0204				
8	N2.3827.00				
9	F105.0219				
10	N6.2691.00				
11	N4.3666.00				
12	N5.1040.00				
13	N5.9016.00				
14	F105.1641				
15	N5.8534.00				
16	N3.1010.50				

Segnalazioni di validità
Usage code
Signalisations de validité
Gültigkeitsvermerk
Indicaciones de validez

destra
 sinistra

FICHES



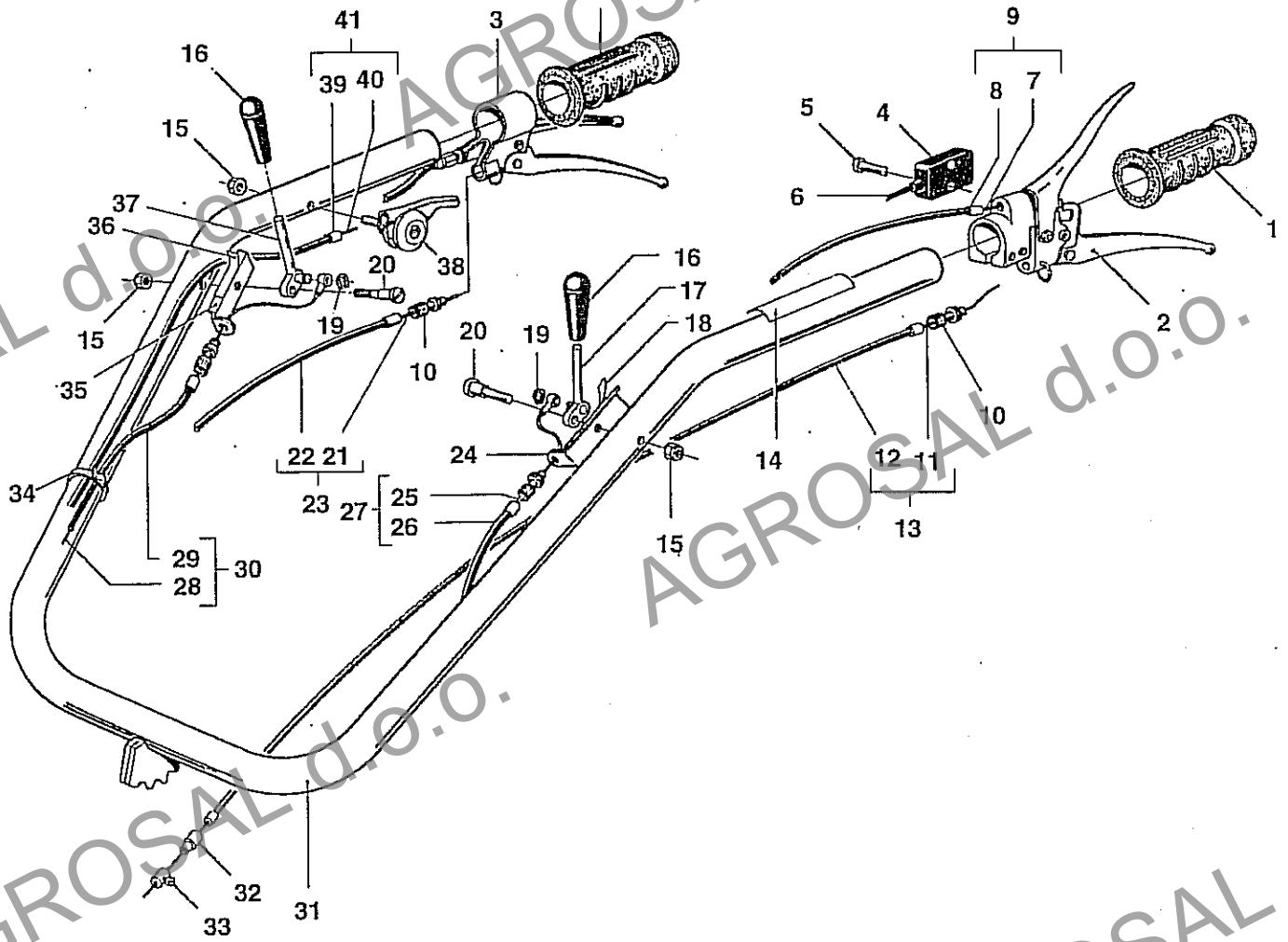

No. pezzo No. pièce No. pièce No. Bild No. pieza	No. di ordinazione Part No. No. de commande Bestell. - Nr. No. de pedido	No. pezzo No. pièce No. pièce No. Bild No. pieza	No. di ordinazione Part No. No. de commande Bestell. - Nr. No. de pedido	No. pezzo No. pièce No. pièce No. Bild No. pieza	No. di ordinazione Part No. No. de commande Bestell. - Nr. No. de pedido
1	N2.8473.00	17	F115.1632.00	36	F109.1690
2	N2.8061.10	18	F105.1680	37	F109.1657
3	N2.8062.00 ●	19	N.1028.00	38	N2.8036.50
-	N2.8061.00 ○	20	F106.1613	39	N5.7258.00 ▲
4	N2.5423.60	21	N5.6359.10	-	N5.7151.30 △
5	N6.1821.50	22	N5.7430.00	-	N5.7256.50 ■
6	F118.2601	23	N5.4902.00 ★	40	N5.6125.00 ▲ ■
7	N5.6240.50 ▲ ■	24	F115.1627	-	N5.6126.50 △
8	N5.7258.60 ▲	25	N5.6485.05	41	N5.4640.00 ▲
-	N5.7256.20 ■	26	N5.7268.50	-	N5.4641.50 △
9	N5.4760.50 ▲	27	N5.5158.40	-	N5.4641.60 □
-	N5.4760.30 ■	28	N5.6488.05	-	N5.4639.50 ■
10	N5.8010.00	29	N5.7273.50		
11	N5.6334.00	30	N5.5165.10		
12	N5.7271.00	31	F118.1625		
13	N5.4861.00	32	N5.8534.00		
14	N5.4070.00	33	N5.9016.00		
15	N1.4547.00	34	N1.7640.00		
16	N3.7523.00	35	F109.1687		

Segnalazioni di validità
Usage code
Significations de validité
Gültigkeitsvermerk
Indicaciones de validez

▲ per motori INTERMOTOR 6LD360
△ per motori ALN330 - CA340
□ per motori HONDA
○ un freno
● due freni
★ per freno destro e sinistro
■ per motori MC71

FICHES



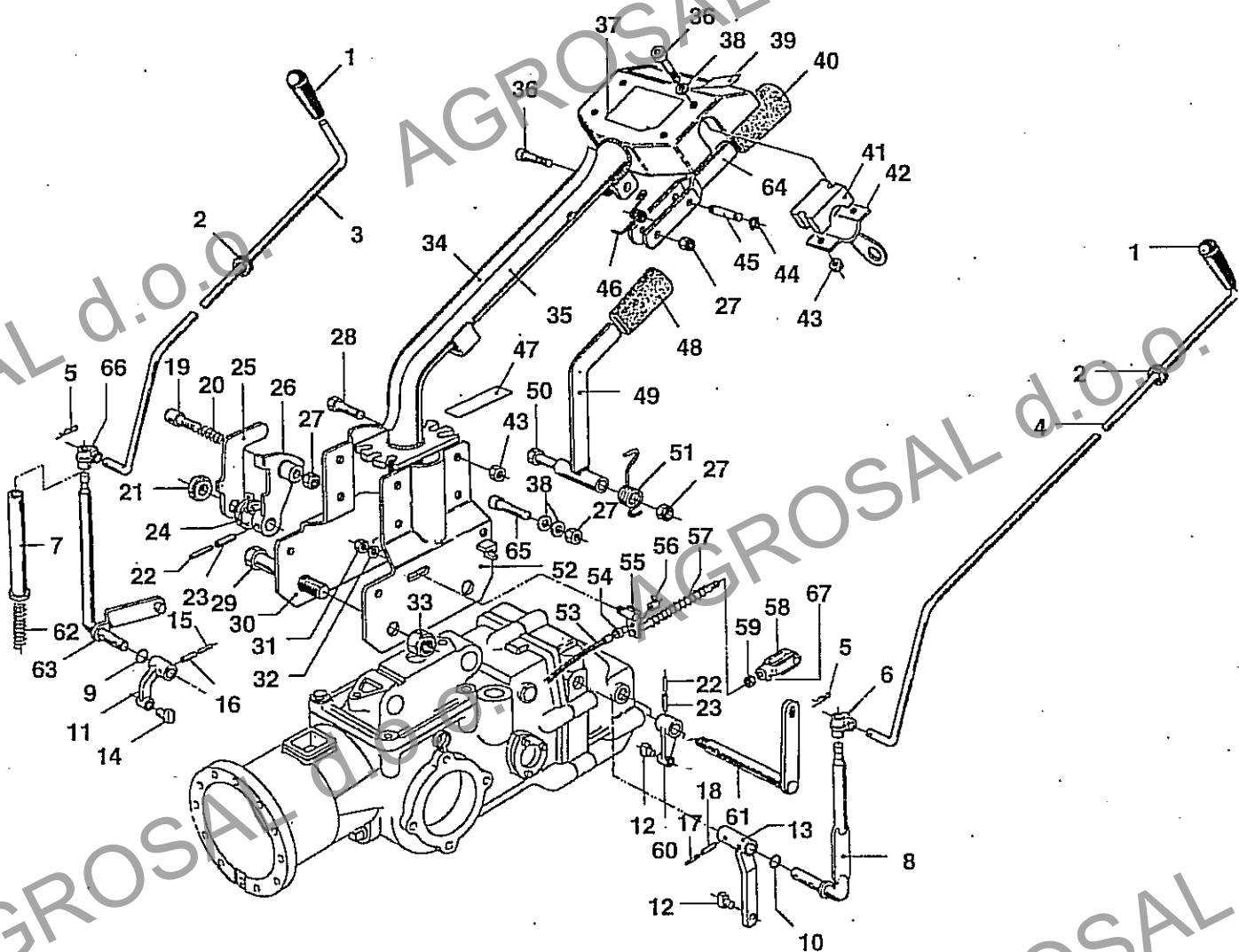

No. pezzo No. pièce No. pièce No. Bild No. pieza	No. di ordinazione Part No. No. de commande Bestell. - Nr. No. de pedido	No. pezzo No. pièce No. pièce No. Bild No. pieza	No. di ordinazione Part No. No. de commande Bestell. - Nr. No. de pedido	No. pezzo No. pièce No. pièce No. Bild No. pieza	No. di ordinazione Part No. No. de commande Bestell. - Nr. No. de pedido
1	N3.7536.00	24	F118.1636	46	F118.1620
2	N.4029.00	25	F121.1602	47	F121.1610
3	F118.1639	26	F118.1635	48	N2.8404.70
4	F121.1609	27	N1.4585.00	49	F118.1604
5	N5.1357.00	28	N6.2724.00	50	N6.3000.00
6	F121.1603	29	N6.4331.10	51	F118.1605
7	F121.1604	30	F120.1601	52	F118.1602
8	F121.1608	31	N1.4642.00	53	N5.5165.10
9	N.3176.00	32	N4.3806.00	54	N5.8534.00
10	N.3175.00	33	N1.4751.10	55	F121.1601
11	F105.1706	34	F118.2109	56	N5.9016.00
12	F105.0831	35	F118.1624	57	N3.1101.00
13	F109.1601	36	N6.2852.00	58	N6.0058.10
14	F109.0818	37	F118.2108	59	N1.4569.00
15	N5.1040.00	-	N5.3935.00 *	60	F105.1700
16	N5.1173.00	38	N4.3694.00	61	F118.1637
17	N5.1043.00	39	F121.1611	62	N3.1184.70
18	N5.1178.00	40	N2.8404.80	63	F121.1607
19	F118.1644	41	F118.1646	64	F118.1643
20	N3.1057.00	42	F118.1618	65	N6.2752.00
21	N2.1008.00	43	N1.4588.00	66	F106.1633
22	N5.1093.00	44	N.1029.00	67	N6.0058.20
23	N5.1255.00	45	N5.1356.10		

Segnalazioni di validità
Usage code
Signalisations de validité
Gültigkeitsvermerk
Indicaciones de validez

* GEMAC

FICHES



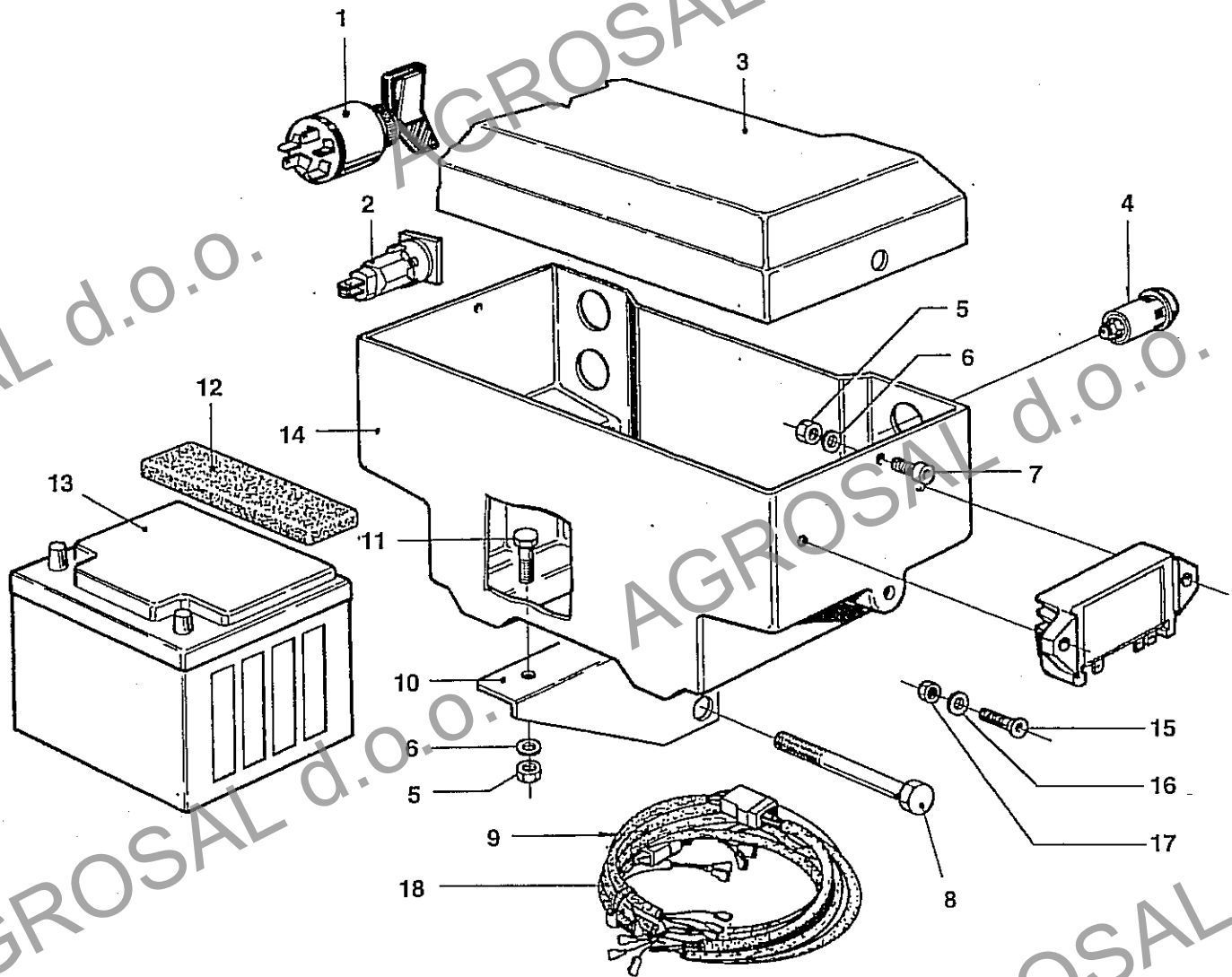

No. pezzo No. pièce No. Blind No. pieza	No. di ordinazione Part No. No. de commande Bestell.-Nr. No. de pedido	No. pezzo No. pièce No. Blind No. pieza	No. di ordinazione Part No. No. de commande Bestell.-Nr. No. de pedido	No. pezzo No. pièce No. Blind No. pieza	No. di ordinazione Part No. No. de commande Bestell.-Nr. No. de pedido
1	N2.5004.20	16	N4.3542.00 ▲		
2	N2.5522.50	-	N4.3585.00 ▲▼		
3	F118.2604	17	N1.4529.80 ▲		
4	N2.5523.70	-	N1.4547.00 ▲▼		
5	N1.4585.00	18	F109.2621 ★▲		
6	N4.3685.00		F109.2623 ★△		
7	N6.2495.10		F109.2625 ★▼		
8	N6.4332.10				
9	F109.2622 ●▲				
-	F109.2624 ●△				
-	F109.2626 ●▼				
10	F118.2605 🖐				
-	F118.2606 🖐				
11	N6.2555.00				
12	F109.2628				
13	N2.5154.50				
14	F118.2603				
15	N6.1934.85 ▲				
-	N6.2185.00 ▲▼				

Segnalazioni di validità
Usage code
Signalisations de validité
Guilgkeitsvermerk
Indicaciones de validez

🖐 destra
🖐 sinistra

▲ ALN 330
△ IM350
▼ 6 LD 360

● cavi avviamento elettrico
★ impianto completo avviamento elettrico

FICHES



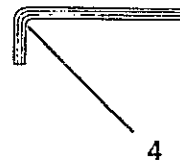
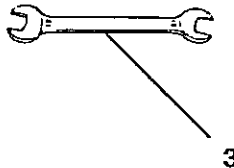
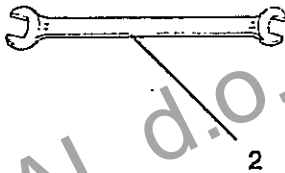
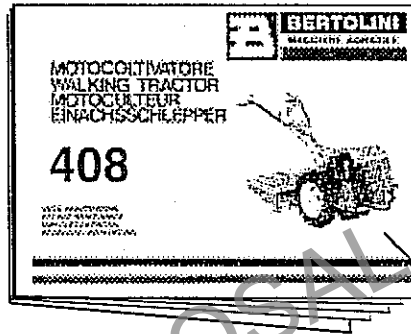
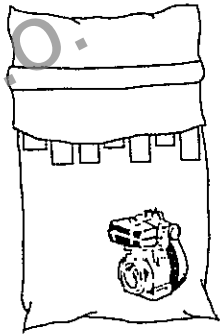

No. pezzo No. pièce No. pièce No. Bild No. pieza	No. di ordinazione Part No. No. de commande Bestell. - Nr. No. de pedido	No. pezzo No. pièce No. pièce No. Bild No. pieza	No. di ordinazione Part No. No. de commande Bestell. - Nr. No. de pedido	No. pezzo No. pièce No. pièce No. Bild No. pieza	No. di ordinazione Part No. No. de commande Bestell. - Nr. No. de pedido
1	F121.4701				
2	N.7059.00				
3	N.7028.00				
4	N.7021.00				

Segnalazioni di validità
Usage code
Signalisations de validité
Gültigkeitsvermerk
Indicaciones de validez

FICHES

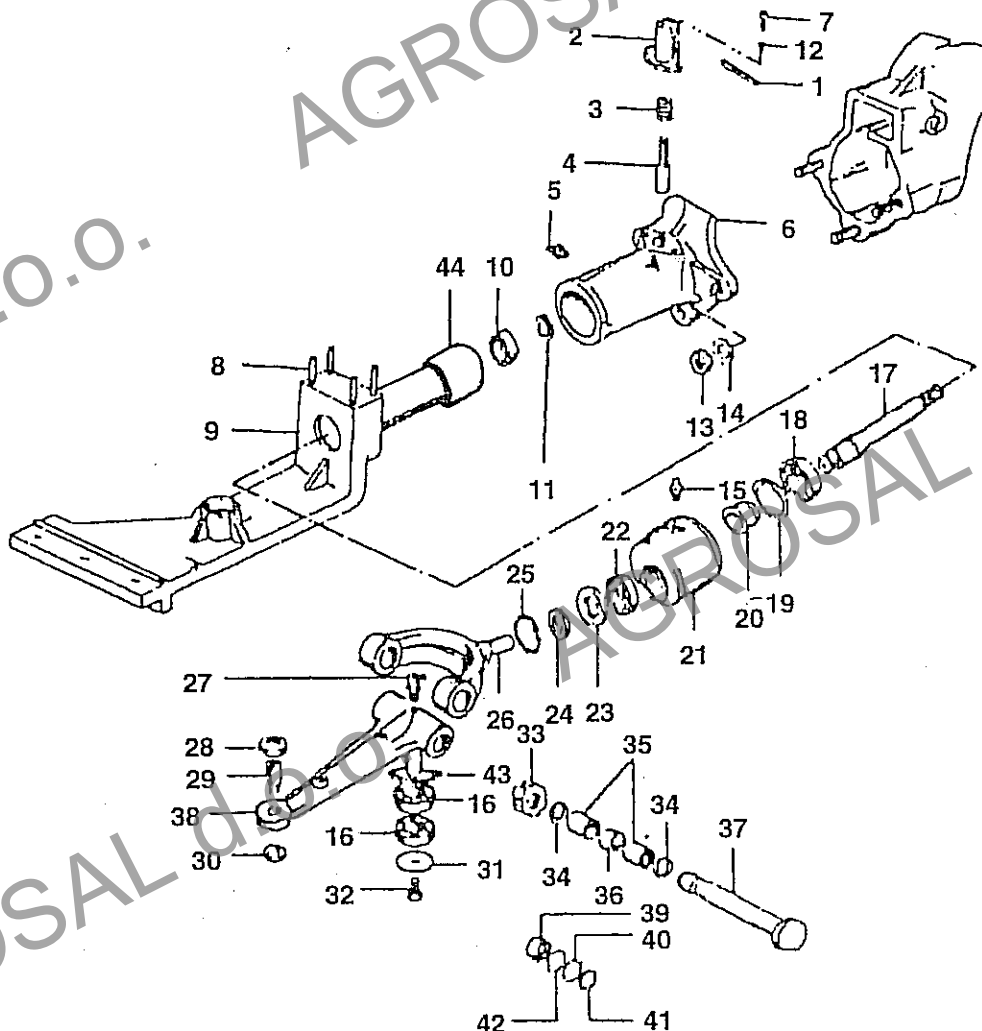

No. pezzo No. pièce No. Bild No. pieza	No. di ordinazione Part No. No. de commande Bestell.-Nr. No. de pedido	No. pezzo No. pièce No. Bild No. pieza	No. di ordinazione Part No. No. de commande Bestell.-Nr. No. de pedido	No. pezzo No. pièce No. Bild No. pieza	No. di ordinazione Part No. No. de commande Bestell.-Nr. No. de pedido
1	N5.1294.50	-	N1.2711.00 Δ 6205	33	N2.1016.00 \blacksquare
2	F115.4702	17	F107.306	34	N5.0028.50 \blacksquare
3	N3.1187.00	18	N1.2711.00	35	N1.2613.50 \blacksquare DNK 20/20
4	F105.4710	19	N.1368.00 H52	36	F107.3190 \blacksquare
5	N2.6056.00	20	F107.3145	37	F107.3191 \blacksquare
6	F105.4740	21	F107.3105	38	F107.3207 \bullet \blacksquare
7	N6.2166.00	22	N1.2583.00 6203	-	F107.3209 \square
8	N3.8109.00	23	N.2057.20	-	F71.1016 \circ
9	F107.3103 \bullet	24	N4.4195.50	39	N1.1534.00 \circ
-	F107.3210 \square	25	N.1300.00 H40	40	F74.0811 \circ
-	F107.3358 Δ	26	F107.3206	41	N.1208.00 \circ
10	N1.2632.00 6004.2RS	-	F71.1011 \circ	42	F74.0810 \circ
11	N.1149.00 A20	27	N2.6056.00	43	N5.0054.00 \square
12	N4.3593.00	28	N1.4745.00	44	F118.4702
13	N1.4705.00	29	F71.1019		
14	N4.3877.00	30	F71.1018		
15	N2.6056.00	31	N4.3821.50 \bullet		
16	N1.2632.00 \bullet 6004.2RS	-	N4.3821.80 \square		
-	N1.2704.00 \square 6005.2RS	32	N6.3205.00		

Segnalazioni di validità
Usage code
Signalisations de validité
Gulligkeitsvermerk
Indicaciones de validez

\circ 17999 \rightarrow \blacksquare 18000 \rightarrow Δ 32337 \rightarrow
 \bullet \rightarrow 22898 \square 22899 \rightarrow
 CODICE BARRA

FICHES



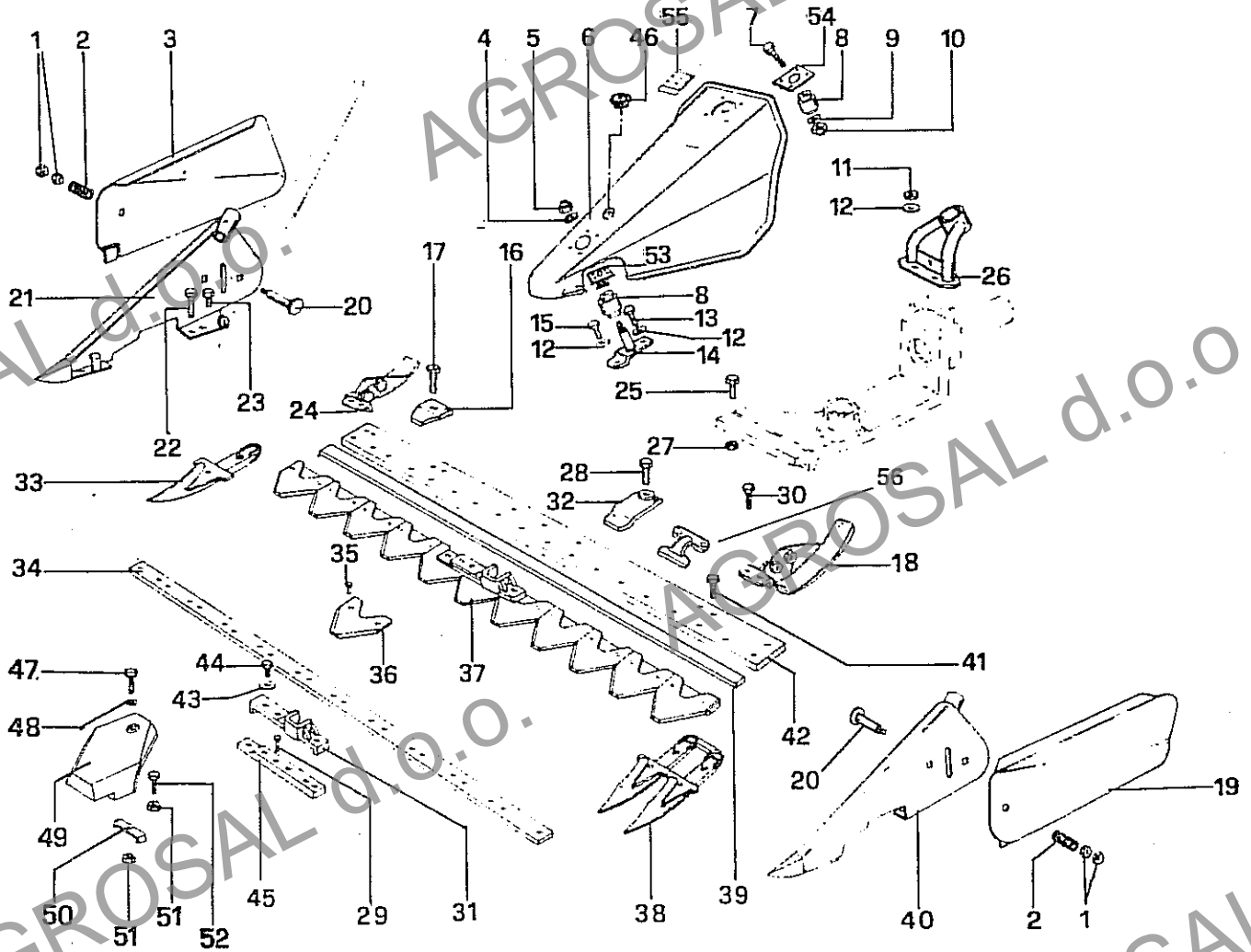

No. pezzo No. pièce No. pièce No. Bild No. pieza	No. di ordinazione Part No. No. de commande Bestell. - Nr. No. de pedido	No. pezzo No. pièce No. pièce No. Bild No. pieza	No. di ordinazione Part No. No. de commande Bestell. - Nr. No. de pedido	No. pezzo No. pièce No. pièce No. Bild No. pieza	No. di ordinazione Part No. No. de commande Bestell. - Nr. No. de pedido
1	N1.4689.00	21	F74.1609	-	F71.2027 L= 950
2	N3.1291.00	22	N6.3148.00	-	F71.2031 L=1150
3	F71.2015	23	N6.3275.00	-	F59.1593 L=1270
4	N4.3806.00	24	F107.3170	-	F107.3220 L=1450
-	N4.3812.00	25	N6.3328.00	40	F74.1635
5	N1.4638.00	26	F107.3112	41	N6.3221.00
6	F107.3144	27	N1.4638.00	42	F74.1684 L= 800
-	R107.6067	28	N6.3275.00	-	F74.1685 L= 950
7	N6.4285.00	29	N.8880.00	-	F74.1686 L=1150
-	N6.3997.10	30	N6.3149.00	-	F74.1689 L=1270
8	N4.9244.00	31	F107.3124	-	F107.3192 L=1450
-	N4.9240.00	32	F58.2686	43	N4.3666.00
9	N4.3921.50	33	F58.2738	44	N6.2457.00
-	N4.3844.10	34	F71.2006 L= 800	45	F107.3122
10	N1.4767.60	-	F71.2028 L= 950	46	N5.2612.70
-	N1.4702.00	-	F4.0411 L=1150	47	N6.2908.00 *
11	N1.4580.00	-	F4.0412 L=1270	48	N4.3666.00 *
12	N4.5667.00	-	F107.3218 L=1450	49	F105.3101 *
13	N6.2670.00	35	N.8866.00	50	F105.3102 *
14	F107.3111	36	F58.2091	51	N1.4579.00 *
-	F107.3215	37	F107.3126 L= 800	52	N6.2784.00 *
15	N6.2555.00	-	F107.3127 L= 950	53	R107.6000
16	F58.2687	-	F107.3128 L=1150	-	P898
17	N6.3275.00	-	F107.3150 L=1270	54	F107.3113
18	F107.3171	-	F107.3219 L=1450	55	N5.3921.60
19	F74.1634	38	F58.2688	56	F58.2685
20	N6.4040.00	39	F71.2008 L= 800		

Segnalazioni di validità
Usage code
Signalisations de validité
Gültigkeitsvermerk
Indicaciones de validez

▲ 6 LD 360

* per motori diesel
(a richiesta)

□ → 25655
■ 25656 →

✎ destra
✎ sinistra

FICHES
[]

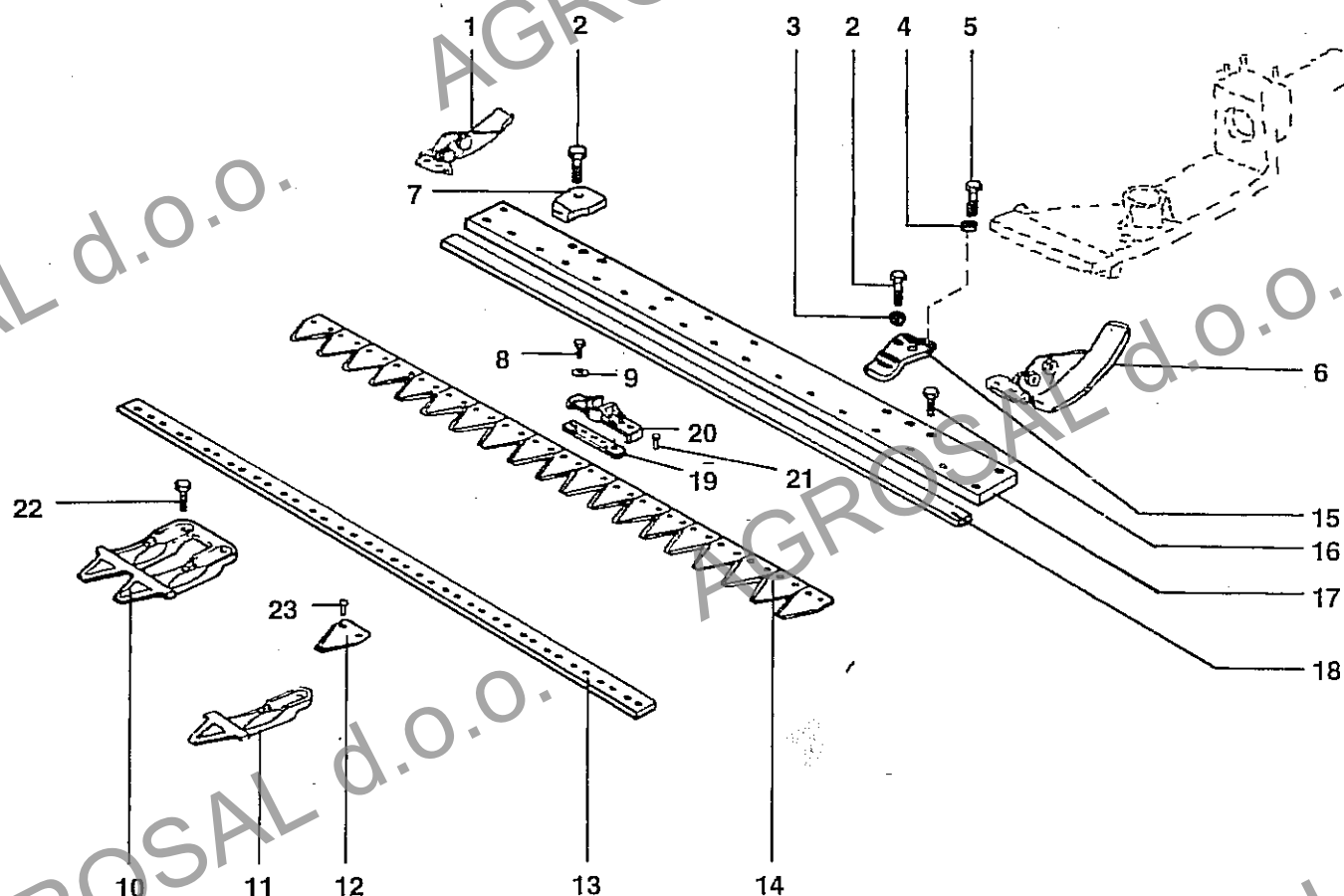

No. pezzo No. pièce No. pièce No. Bild No. pieza	No. di ordinazione Part No. No. de commande Bestell. - Nr. No. de pedido	No. pezzo No. pièce No. pièce No. Bild No. pieza	No. di ordinazione Part No. No. de commande Bestell. - Nr. No. de pedido	No. pezzo No. pièce No. pièce No. Bild No. pieza	No. di ordinazione Part No. No. de commande Bestell. - Nr. No. de pedido
1	F107.3170	-	F74.1628 L= 950	20	F107.3124
2	N6.3333.00	-	F107.3154 L=1270	21	N8880.00
-	N6.2457.00 tipo doppio	14	F107.3137 L=1150 □	22	N6.3221.00
3	F107.3119	-	F107.3216 ■	23	N8866.00
4	N1.4628.00	-	F107.3136 L= 950		
5	N6.3153.00	-	F107.3152 L=1270		
6	F107.3171	-	F107.3194 L=1450		
7	F58.2687	15	F107.3118		
8	N6.2457.00 Bocca mg X12	-	F111.3112 tipo doppio		
9	N4.3666.00 Veering mg	16	N6.3149.00		
10	F111.3114	17	F74.1686 L=1150		
11	F111.3113	-	F74.1685 L= 950		
12	F74.1683 ▣ ▽	-	F74.1689 L=1270		
-	F107.3216 ▣ ▽	-	F107.3192 L=1450		
-	F74.1683 □ △	18	F71.2031 L=1150		
-	F107.3216 ▣ ▽	-	F71.2027 L= 950		
-	F74.1683 ▣ ▽	-	F59.1593 L=1270		
-	F107.3216 ▣ △ ▲	-	F107.3193 L=1450		
13	F107.3125 L=1150	19	F107.3123		

Segnalazioni di validità
Usage code
Signalisations de validité
Gültigkeitsvermerk
Indicaciones de validez

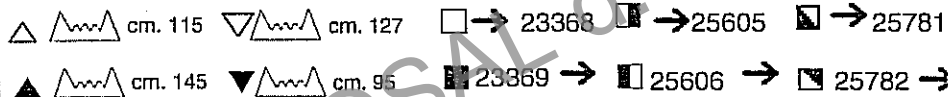

FICHES



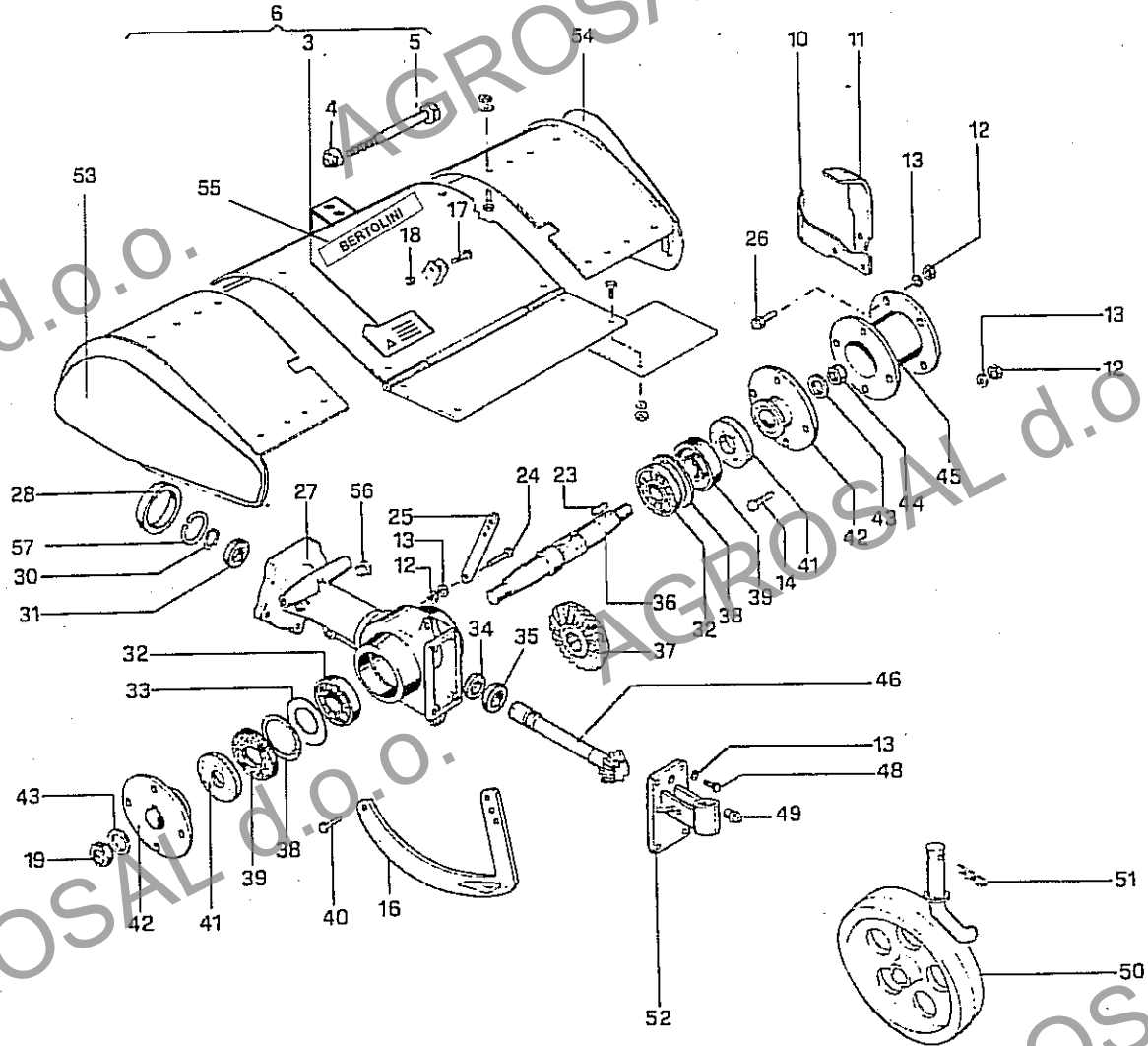

No. pezzo No. pièce No. pièce No. Bild No. pieza	No. di ordinazione Part No. No. de commande Bestell. - Nr. No. de pedido	No. pezzo No. pièce No. pièce No. Bild No. pieza	No. di ordinazione Part No. No. de commande Bestell. - Nr. No. de pedido	No. pezzo No. pièce No. pièce No. Bild No. pieza	No. di ordinazione Part No. No. de commande Bestell. - Nr. No. de pedido
3	F1.5577	30	N.1149.00 A20	48	N6.2554.00
4	N1.4767.60	31	N1.2632.00 6004.2R5	49	N5.2540.00
5	N6.4337.70	32	N1.2707.00 6205	50	F67.1403
6	F1.5527	33	N5.0068.00	51	N5.1497.00
10	F1.5517 ↓	34	N.2074.00 0K20x35x10	52	F1.5540
11	F1.5518 ↓	35	N1.2640.51 3204	53	F1.5574
12	N1.4573.00	36	F1.3531	-	N5.3813.00 *
13	N4.3666.00	37	F1.5582 □	54	F1.5573
14	N6.2740.00	-	F1.5503 ■	-	N5.3813.00 *
16	F1.5548	38	N.1368.00 H52	55	N5.3828.35
17	N6.2670.00	39	N.2100.50 0K25x52x7	56	N5.2536.00
18	N1.4574.00	40	N6.2669.00	57	N1309.00 H42
19	N1.4826.00 ↓	41	F1.3525		
23	N.6522.00	42	F1.5510		
24	N6.2723.00	43	N4.4180.00		
25	F1.3514	44	N1.4825.00 ↓		
26	N6.2622.00	45	F1.5515		
27	F1.5512	46	F1.5581 □		
28	F1.3529	-	F1.5502 ■		

Segnalazioni di validità
Usage code
Signalisations de validité
Gültigkeitsvermerk
Indicaciones de validez

↓ DESTRA
↓ SINISTRA

□ Z= 7/22 m= 4,25
■ Z= 9/28 m= 3,25

* Targhetta "GEMAC"

FICHES



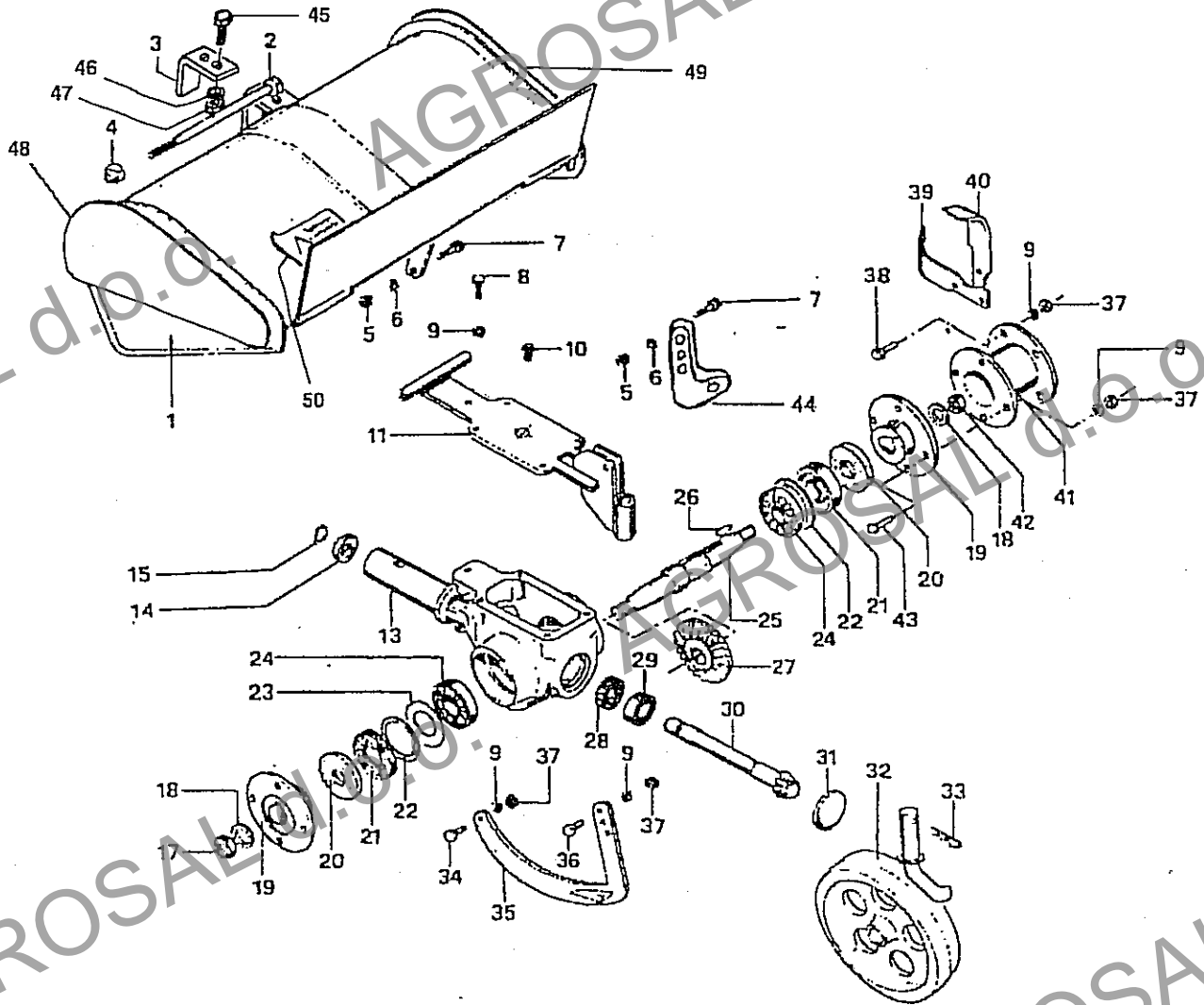

No. pezzo No. pièce No. pièce No. Bild No. pieza	No. di ordinazione Part No. No. de commande Bestell. - Nr. No. de pedido	No. pezzo No. pièce No. pièce No. Bild No. pieza	No. di ordinazione Part No. No. de commande Bestell. - Nr. No. de pedido	No. pezzo No. pièce No. pièce No. Bild No. pieza	No. di ordinazione Part No. No. de commande Bestell. - Nr. No. de pedido
1	F1.5527	21	N.2100.50 0K25x52x7	38	N6.2669.00
2	N6.4337.70	22	N.1368.00 H52	39	F1.5517
3	F01.5572	23	N5.0068.00	40	F1.5518
-	F01.5578 *	24	N.2707.00 6205	41	F1.5515
4	N1.4767.60	25	F1.3531	42	N1.4825.00
5	N1.4574.00	26	N.6522.00	43	N6.2740.00
6	N4.3667.00	27	F1.5582	44	F1.5552
7	N6.2670.00	-	F1.5503	45	N6.2488.00
8	N6.2554.00	28	N.2074.00 0K20x35x10	46	N4.3685.00
9	N4.3666.00	29	N1.2640.50 3204	47	N1.4574.00
10	N5.2540.00	30	F1.5583	48	F01.5574
11	F1.5542	-	F1.5544	-	N5.3813.00
13	F1.5541	31	N5.2767.00	49	F01.5573
14	N1.2632.00 6004.2R5	32	L67.1403	-	N5.3813.00
15	N.1149.00 A20	33	N5.1497.00	50	F01.5577
17	N1.4826.00	34	N6.2669.00		
18	N4.4180.00	35	F1.5548		
19	F1.5547	36	N6.2669.00		
20	F1.3525	37	N1.4573.00		

Segnalazioni di validità
Usage code
Signalisations de validité
Gültigkeitsvermerk
Indicaciones de validez

✎ DESTRA
✎ SINISTRA
* OMOL. GS

○ Targhetta "GEMAC"
□ Z= 9/28 m= 3,25
■ Z= 7/22 m= 4,25

FICHES

