

AGROSAL d.o.o.



TH34D – AF30E



AGROSAL d.o.o.

*Gregorčičeva ulica 38, 5270 Ajdovščina
telefon: 05 368 90 96, fax: 05 368 90 97
e-mail: info@agrosal.si, www.agrosal.si*

This catalog covers:
TH034D-□F30

This fig. covers:
TITLE

PARTS CATALOG

2-STROKE ENGINE

TH034D

PRODUCT CODE	NOTE
TH034D-AF30	BRUSH-CUTTER

This catalog covers:
TH034D-□F30

PARTS CATALOG INTRODUCTION

This parts catalog lists parts and sub-assemblies provided as service parts.

When it becomes necessary to replace parts, always use KAWASAKI GENUINE PARTS which have passed strict inspection which guarantees quality and performance.

1. HOW TO ORDER PARTS

- 1) When ordering the parts, be sure to use the parts catalog corresponding to the product code. Check the product revision codes on the product and the catalog.
Product Code (example) : FA130D-**AA00**

Product Revision Code
- 2) Specify the part code (all digits) exactly as listed in this catalog on your parts order.
- 3) The parts not shown in the illustrations of this catalog are not sold separately; only the complete units or next higher assemblies illustrated are supplied as the service parts.

2. EXPLANATION OF PARTS CATALOG FORMAT

This catalog covers: **TH026D-□A10**

This fig. covers: **01 CYLINDER/CRANKCASE**

Ref. No.	Part No.	Description	Quantity
11005	11005-2137	CYLINDER-ENGINE	1
11060	11060-2402	GASKET-CYLINDER	1
11065	11065-2564	CLIP	2
14002	14002-2327	CRANKCASE	1
14002A	14002-2328	CRANKCASE	1
34001	34001-2083	STAND	1
92009	92009-2415	SCREW	3
92043	92043-1502	PIN	2
92045	92045-2006	BEARING-BALL.6000C3	2
92069	92069-2074	SEAL-OIL	2
92150	92150-2091	BOLT	4

1) Product Code

This code describes the product code covered by this catalog. The product revision code, which is a part of the product code, is omitted.

2) Part Group Title

This title is the representative name for the group of parts illustrated on the page.

3) Reference Number

The reference numbers are shown on the illustration and the list as the link between them.

This fig. covers:
PARTS LIST INFORMATION

4) Part Number

This is the key of your parts ordering.

Three kinds of part number are used in this catalog.

a. Structure 1

□□□□□□-□□□□-□□
 □□□□□□-□□□□□□
Part Revision Code

b. Structure 2

□□□□□□-□□□□-□□
Color Code for Painted Part

c. Standard Hardware Number (for bolts, nuts, washer, or the like)

□□□□□□□□
Size Code
Material and Surface Treatment Code
Item Code

5) Description and Additional Information

The part name, the location, the size, and the serial number as additional information, etc. are described here. Use them to find out and check the part required.

When a part number is changed without change of the product revision code and the changed parts are not interchangeable, the serial number of the product is noted as follows;

- (- FA130 - 100001) : Affected units are from beginning of the product of the product code up to and including this serial number.
- (FA130 - 100002 -) : Affected units are from this serial number and above.
- (FA130 - 100002 - FA130 - 110001) : Affected units are in this serial number range.

6) Quantity

The figure shows quantity of the part required at the indicated position on the illustration and for the specified product revision code.

The asterisk (*) on this column means the part can be used as the substitute on the product and is supplied until the stock is exhausted.

Note: Some small parts will be supplied by units.

Example: If six (6) bolts are ordered and the minimum quantity per unit is five (5), two (2), units of the bolt will be delivered.

7) Product Revision Code

This Code indicates an important change which affects the service parts interchangeability.

3. ABBREVIATIONS

#.....Number	FR.....Front	RH.....Right Hand
&.....And	G.....Gram	RPM.....Revolutions Per Minute
(+).....Plus	HEX.....Hexagonal	RR.....Rear
(-).....Minus	ID=.....Inside Diameter	STD.....Standard
2ND.....Second	IN.....Inch	T.....Teeth
3RD.....Third	L=.....Length	T=.....Thickness
4TH.....Fourth	LH.....Left Hand	U/S.....Under Size
A.....Ampere	LWR.....Lower	UPP.....Upper
AR.....As Required	MM.....Millimeter	V.....Volt
ASSY.....Assembly	O/S.....Over Size	W.....Watt
CNT.....Center	OD=.....Outside Diameter	
COMP.....Complete	REF.....Reference	

This catalog covers:

TH034D- □ F30

01

This fig. covers:

CYLINDER/CRANKCASE

E0110-A335A

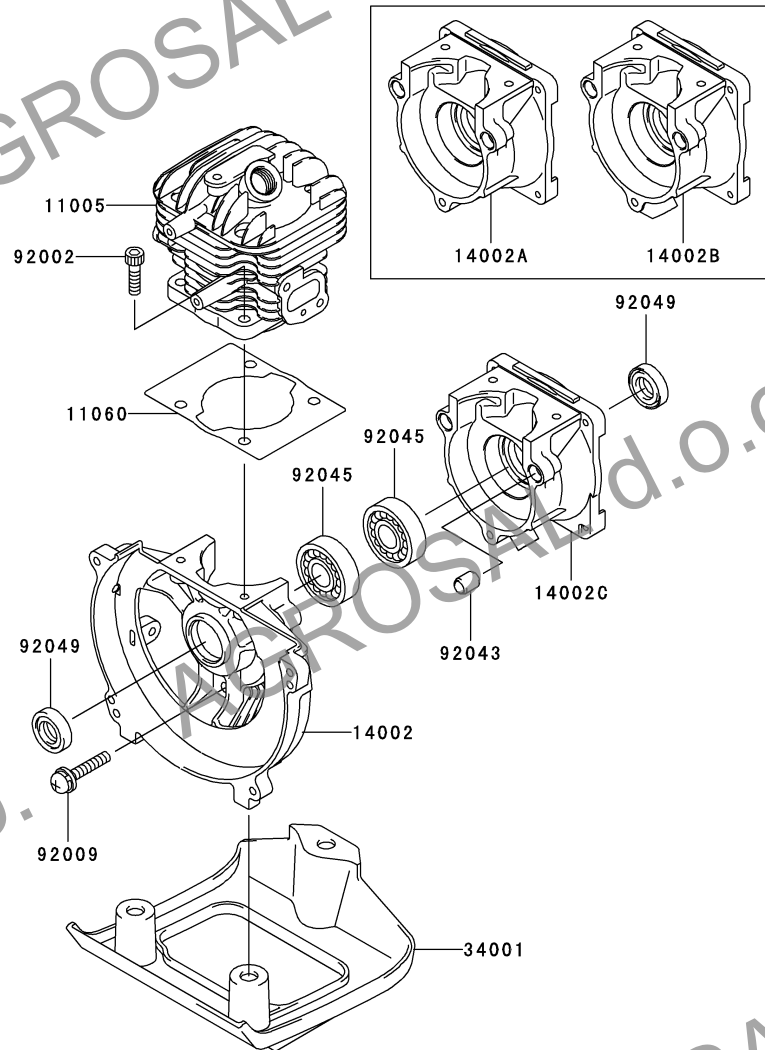

Ref. No.	Part No.	Description	Quantity
11005	11005-2140	CYLINDER-ENGINE	1
11060	11060-2435	GASKET,CYLINDER	1
14002	14002-2331	CRANKCASE	1
14002A	14002-2332	CRANKCASE	*
	(TH034-043608)	
14002B	14002-2335	CRANKCASE	*
	(TH034-043609 -)	
14002C	14002-2347	CRANKCASE	1
34001	34001-2086	STAND	1
92002	92002-2163	BOLT	4
92009	92009-2115	SCREW	3
92043	92043-1302	PIN	2
92045	92045-2058	BEARING-BALL,6201C3	2
92049	92049-2108	SEAL-OIL	2

This catalog covers:

TH034D- F30

02

This fig. covers:

PISTON/CRANKSHAFT

E0120-A147A

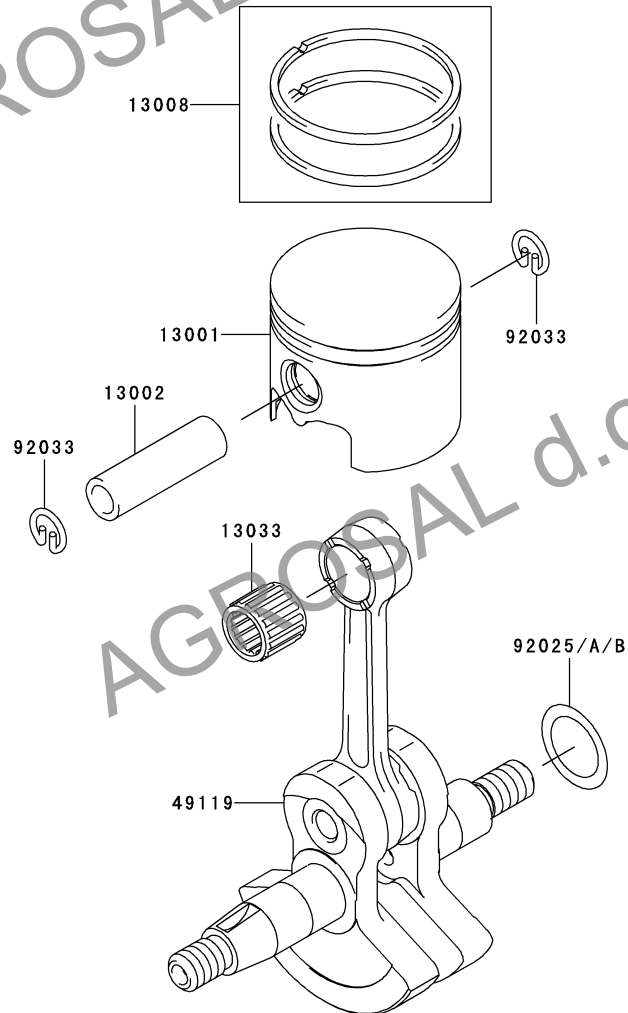

Ref. No.	Part No.	Description	Quantity
13001	13001-2147	PISTON-ENGINE	1
13002	13002-2059	PIN-PISTON	1
13008	13008-6045	RING-SET-PISTON	1
13033	13033-2052	BEARING-SMALL END	1
49119	49119-2190	CRANKSHAFT-ASSY	1
92025	92025-2104	SHIM, T=0.20	AR
92025A	92025-2105	SHIM, T=0.40	AR
92025B	92025-2106	SHIM, T=0.60	AR
92033	92033-2061	RING-SNAP	2

This catalog covers:

TH034D- □ F30

03

This fig. covers:

COOLING-EQUIPMENT

E0150-A304C

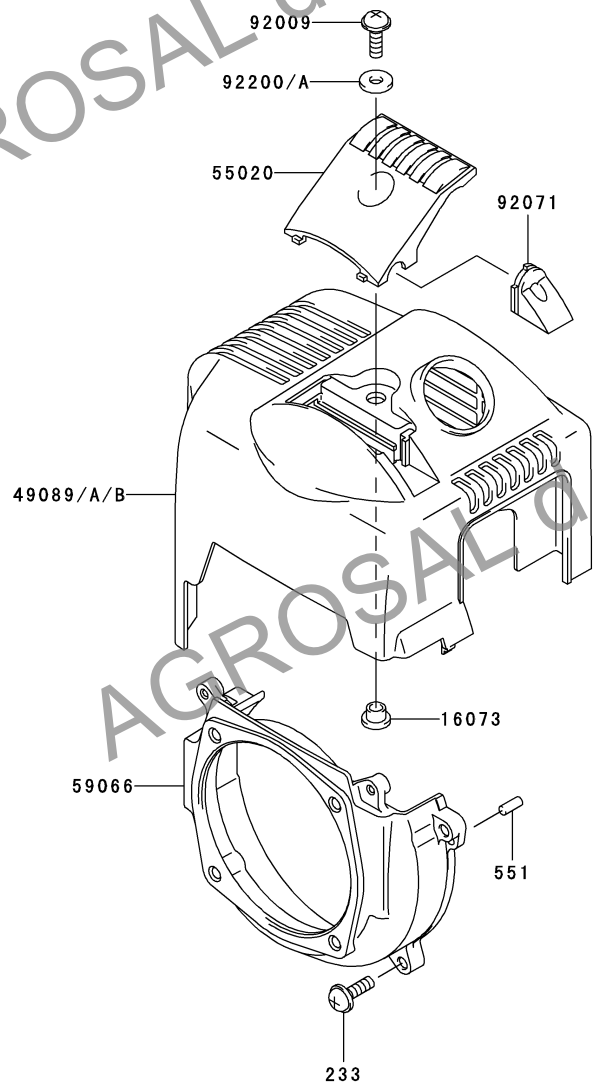

Ref. No.	Part No.	Description	Quantity
16073	16073-2197	INSULATOR	1
49089	49089-2479	SHROUD-ENGINE	*
49089A	49089-2535	SHROUD-ENGINE	*
49089B	49089-2598	SHROUD-ENGINE	1
55020	55020-2125	GUARD	1
59066	59066-2724-9B	HOUSING-FAN	1
92009	92009-2394	SCREW,5X16	1
92071	92071-2157	GROMMET	1
92200	92200-2063	WASHER,5.5X13.8X2.0	*
92200A	92200-2156	WASHER	1
233	233B0516	SCREW-PAN-WP+-	4
551	551A0410	PIN-DOWEL	2

This catalog covers:

TH034D- □ F30

04

This fig. covers:

ELECTRIC-EQUIPMENT

E0160-A826C

Quantity

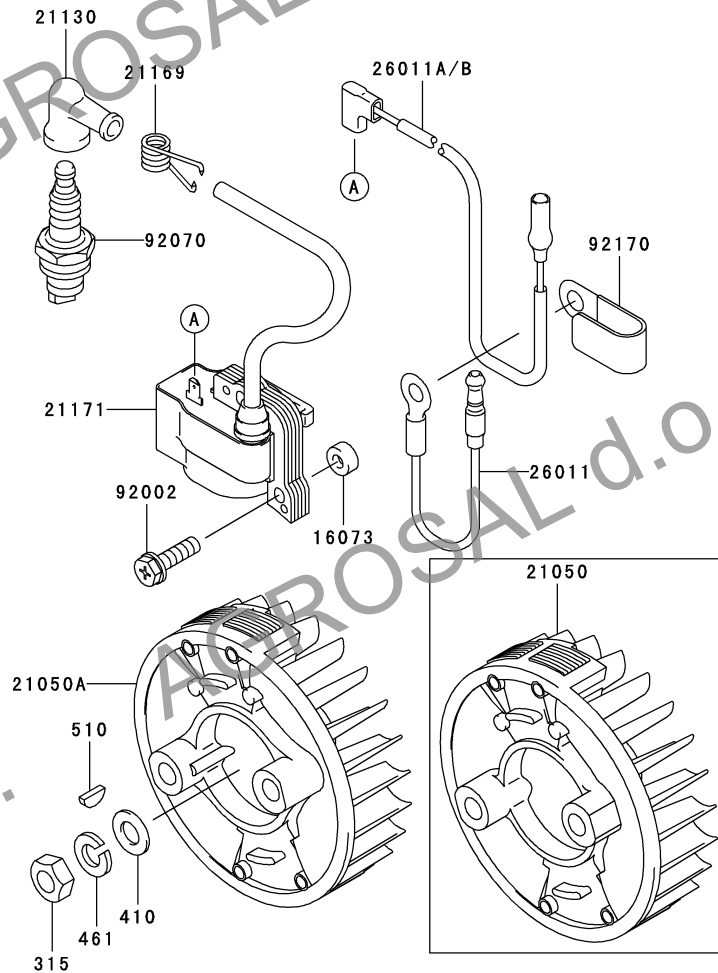

Ref. No.	Part No.	Description	Quantity
16073	16073-2198	INSULATOR	2
21050	21050-2282	FLYWHEEL	*
21050A	21050-2301	FLYWHEEL	1
21130	21130-2056	CAP-SPARK PLUG	1
21169	21169-2051	TERMINAL	1
21171	21171-2234	COIL-ASSY-IGNITION	1
26011	26011-2341	WIRE-LEAD,L=200MM	1
26011A	26011-2361	WIRE-LEAD,L=230	*
26011B	26011-2376	WIRE-LEAD,L=230	1
92002	92002-2197	BOLT,4X20	2
92070	92070-2108	PLUG-SPARK,BPMR6A(NGK),SOLID	1
92170	92170-2041	CLAMP	1
315	315B0800	NUT-HEX-FINE	1
410	410B0800	W-PLAIN-S	1
461	461F0800	WASHER-SPRING	1
510	510A3100	KEY-WOODRUFF	1

This catalog covers:

TH034D- F30

05

This fig. covers:

CONTROL-EQUIPMENT

E0170-A489A

Ref. No.	Part No.	Description	Quantity
32099	32099-2326	CASE	1
54012	54012-2525	CABLE-THROTTLE	1
	(TH034-172537 -)
54012A	54012-2580	CABLE-THROTTLE	1
	(TH034-172536))

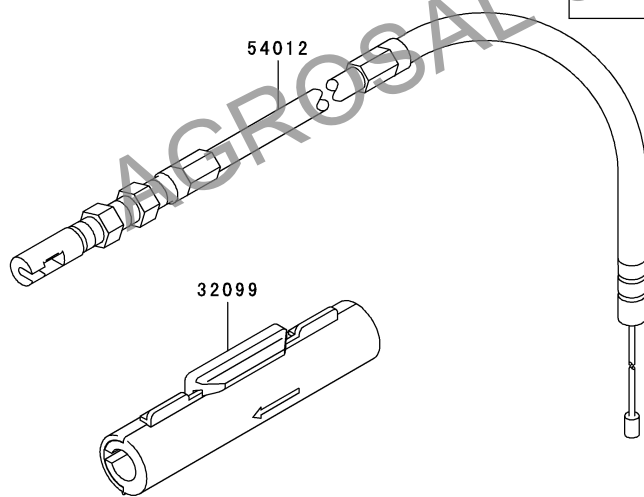
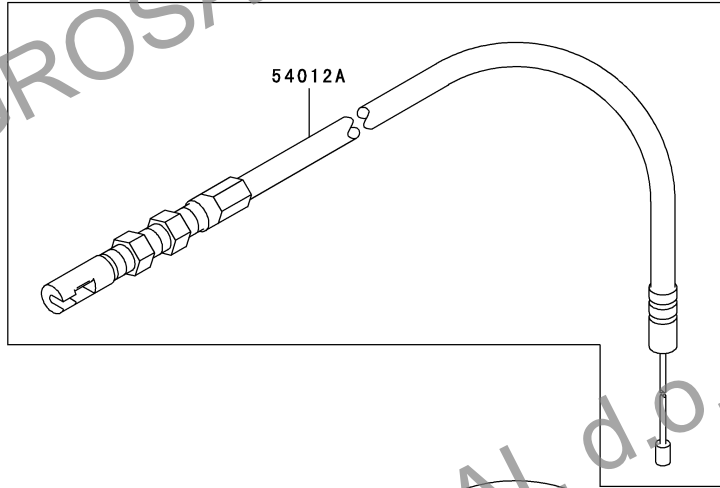

This catalog covers:

TH034D- □ F30

06

This fig. covers:

CARBURETOR

E0180-A357A

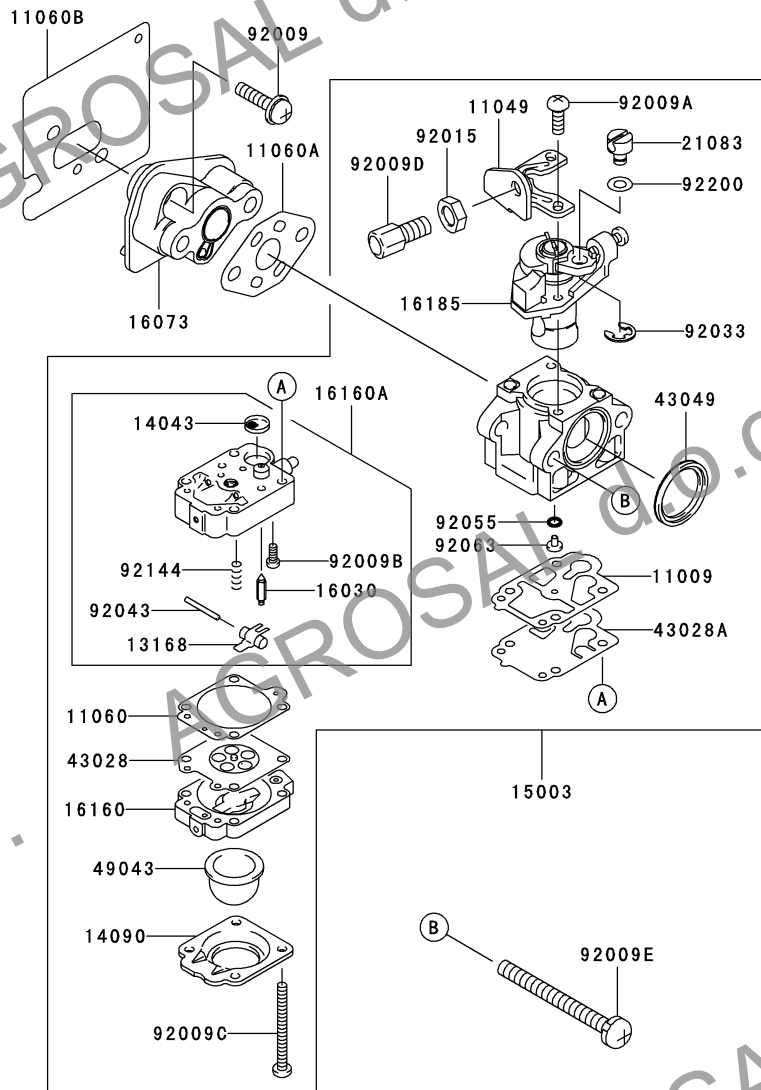

Ref. No.	Part No.	Description	Quantity
11009	11009-2757	GASKET	1
11049	11049-2006	BRACKET	1
11060	11060-2111	GASKET	1
11060A	11060-2404	GASKET,CARBURETOR	1
11060B	11060-2437	GASKET,INSULATOR	1
13168	16055-2051	LEVER	1
14043	14043-2051	FILTER	1
14090	14090-2017	COVER,PRIMER PUMP	1
15003	15003-2688	CARBURETOR-ASSY	1
16030	16030-2078	VALVE-FLOAT	1
16073	16073-2202	INSULATOR	1
16160	16160-2089	BODY	1
16160A	16160-2103	BODY	1
16185	16185-2024	VALVE-ASSY-THROTTLE	1
21083	21083-2073	ARM	1
43028	43028-2054	DIAPHRAGM	1
43028A	43028-2067	DIAPHRAGM	1
43049	43049-2060	PACKING	1
49043	49043-2067	PUMP-PRIMING	1
92009	92009-2249	SCREW,5X20	2
92009A	92009-2277	SCREW	2
92009B	92009-2336	SCREW	1
92009C	92009-2337	SCREW	4
92009D	92009-2354	SCREW	1
92009E	92009-2420	SCREW,5X52	2
92015	92015-2145	NUT	1
92033	92033-2078	RING-SNAP	1
92043	92043-2094	PIN	1
92055	92055-2147	RING-O	1
92063	92063-2356	JET-MAIN,#37.5	1
92144	92144-2308	SPRING	1
92200	92200-2074	WASHER	1

This catalog covers:

TH034D- □ F30

07

This fig. covers:

AIR-FILTER/MUFFLER

E0190-A617A

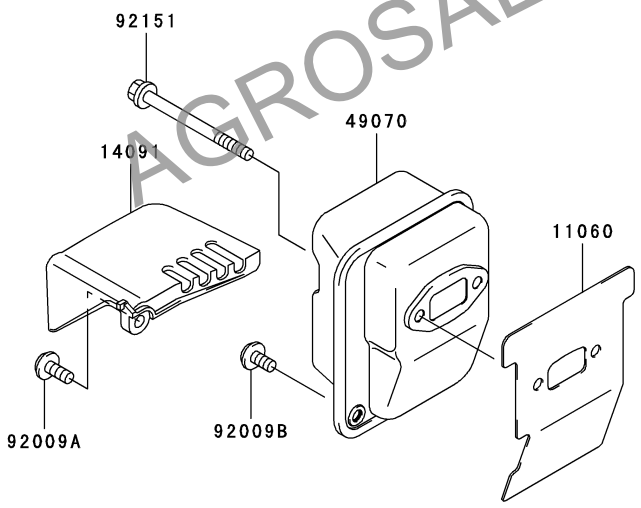
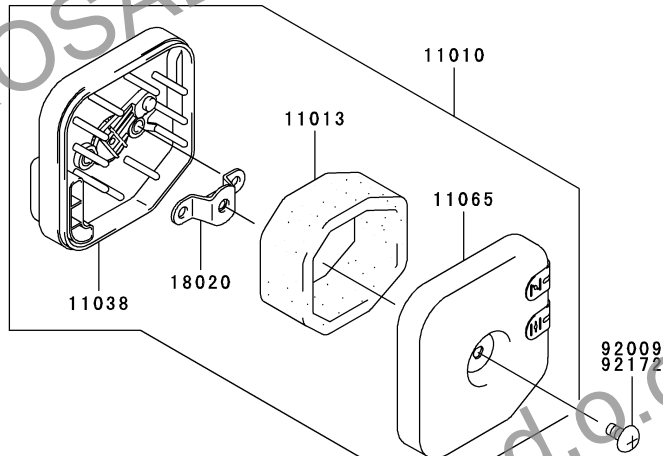

Ref. No.	Part No.	Description	Quantity
11010	11010-2526	FILTER-ASSY-AIR	1
11013	11013-2184	ELEMENT-AIR FILTER	1
11038	11038-2069	CASE-ASSY-AIR FILTER	1
11060	11060-2436	GASKET,MUFFLER	1
11065	11065-2072	CAP,AIR FILTER	1
14091	14091-2053	COVER,MUFFLER	1
18020	18020-2082	BAFFLE	1
49070	49070-2693	MUFFLER-COMP	1
92009	92009-1002	SCREW,5X10	*
92009A	92009-2393	SCREW,5X12	1
92009B	92009-2410	SCREW,5X10	1
92151	92151-2108	BOLT,5X60	2
92172	92172-0007	SCREW,5X10	1

This catalog covers:

TH034D- □ F30

08

This fig. covers:

FUEL-TANK/FUEL-VALVE

E0200-A374A

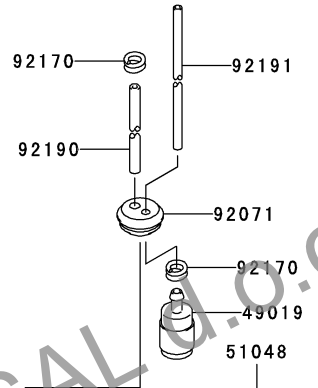
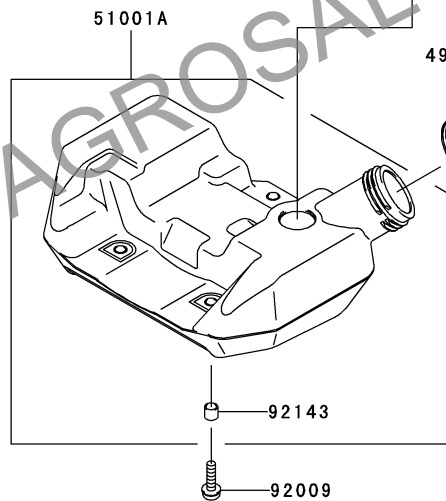
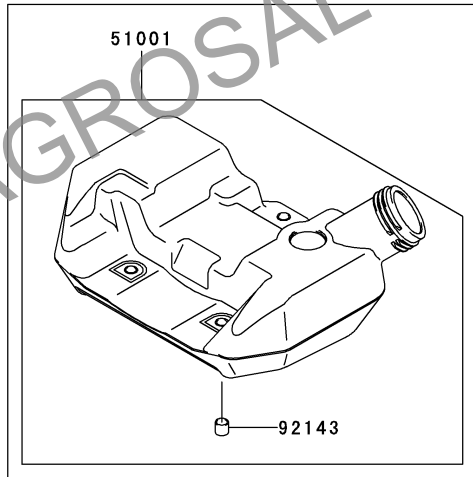

Ref. No.	Part No.	Description	Quantity
49019	49019-2111	FILTER-FUEL	1
49116	49116-2064	VALVE-ASSY	1
51001	51001-2299	TANK-COMP-FUEL	*
51001A	51001-2314	TANK-COMP-FUEL	1
51048	51048-2078	CAP-ASSY-TANK	1
92009	92009-2383	SCREW,5X20	3
92071	92071-2142	GROMMET,FUEL TANK	1
92143	92143-2161	COLLAR,TANK	3
92170	92170-2080	CLAMP,FUEL FILTER	2
92190	92190-2174	TUBE,3X6X90	1
92191	92191-2102	TUBE,3X5X182	1

This catalog covers:

TH034D- F30

09

This fig. covers:

STARTER

E0210-A200B

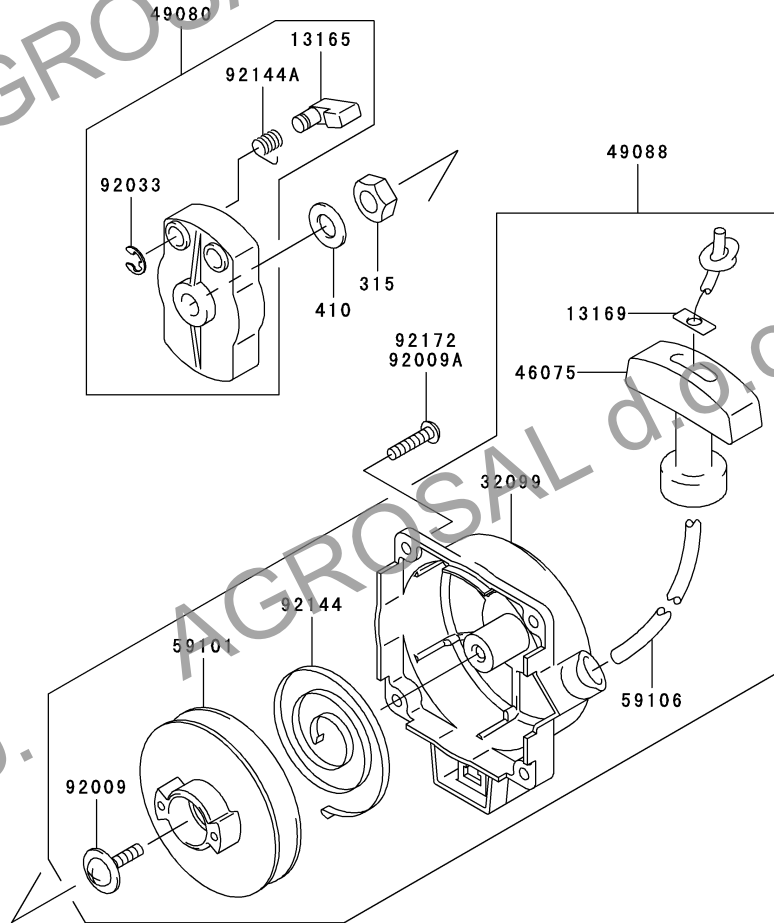

Ref. No.	Part No.	Description	Quantity
13165	13165-2084	PAWL,RECOIL STARTER	1
13169	13169-2386	PLATE,RECOIL STARTER	1
32099	32099-2358	CASE,RECOIL STARTER	1
46075	46075-2128	GRIP,RECOIL STARTER	1
49080	49080-2134	PULLEY-STARTING	1
49088	49088-2500	STARTER-RECOIL	1
59101	59101-2085	REEL,RECOIL STARTER	1
59106	59106-2151	ROPE	1
92009	92009-2358	SCREW	1
92009A	92009-2412	SCREW	*
92033	92033-2010	RING-SNAP	1
92144	92144-2054	SPRING	1
92144A	92144-2157	SPRING	1
92172	92172-2063	SCREW	4
315	315B0800	NUT-HEX-FINE	1
410	410B0800	W-PLAIN-S	1

This catalog covers:

TH034D- □ F30

10

This fig. covers:

P.T.O-EQUIPMENT

E0220-A008A

Ref. No.	Part No.	Description	Quantity
13081	13081-2220	CLUTCH-ASSY	1
49049	49049-2075	SHOE-CLUTCH	2
92022	92026-2125	WASHER	2
92043	92043-2210	PIN, CLUTCH	2
92144	92144-2390	SPRING	1
92200	92200-2064	WASHER, SPRING, 10.5X14.5X0.3	2

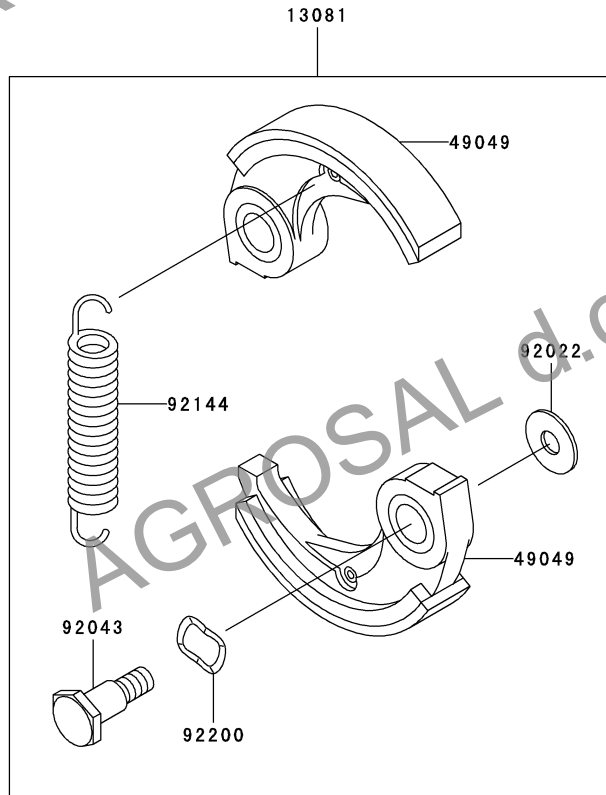

This catalog covers:

TH034D- □ F30

11

This fig. covers:

LABEL

F0290-A691A

Ref. No.	Part No.	Description	Quantity
56039	56039-2890	LABEL-PRODUCT	1
56070	56070-2020	LABEL-WARNING	1
56080	56080-2166	LABEL-BRAND	1

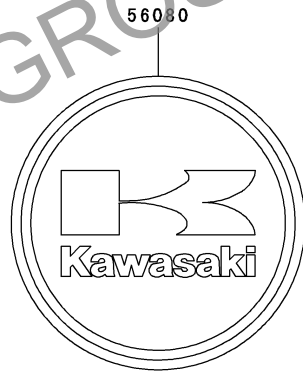
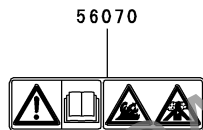
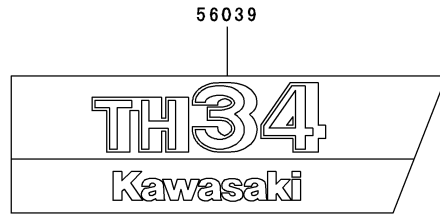

This catalog covers:

TH034D- □ F30

12

This fig. covers:

TOOL

F0300-A001A

Ref. No.	Part No.	Description	Quantity
56007	56007-2051	TOOLKIT	1
92107	92107-2057	TOOL-DRIVER	1
92110	92110-2051	TOOL-WRENCH, 19X21	1

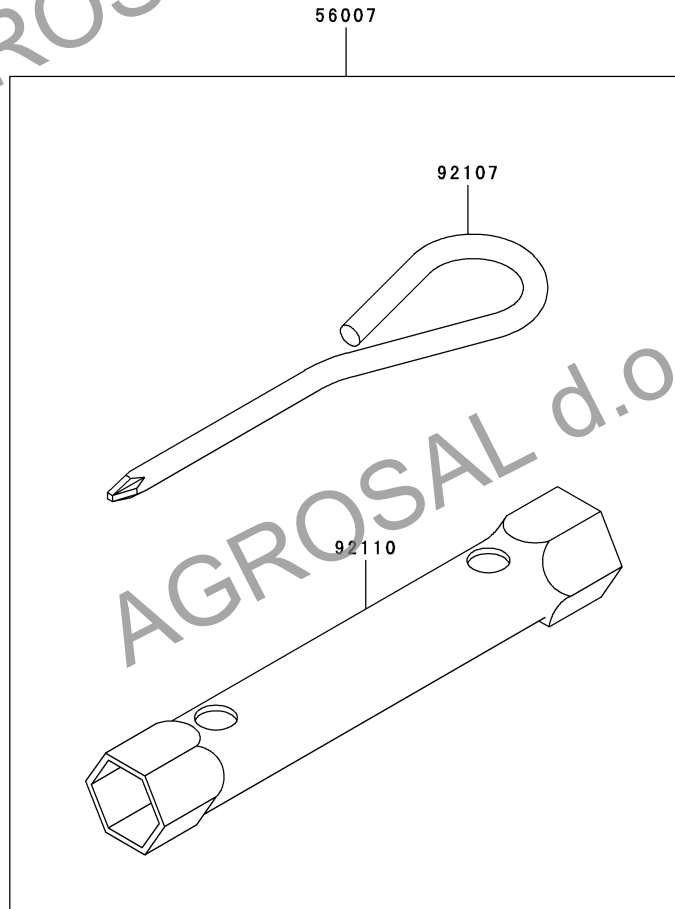

This catalog covers:

TH034D- □ F30

This fig. covers:

PART NAME INDEX

AIR-FILTER/MUFFLER.....	07
CARBURETOR.....	06
CONTROL-EQUIPMENT.....	05
COOLING-EQUIPMENT.....	03
CYLINDER/CRANKCASE.....	01
ELECTRIC-EQUIPMENT.....	04
FUEL-TANK/FUEL-VALVE.....	08
LABEL.....	11
P.T.O-EQUIPMENT.....	10
PISTON/CRANKSHAFT.....	02
STARTER.....	09
TOOL.....	12

This catalog covers:

TH034D- F30

This fig. covers:

NUMERICAL PARTS INDEX

Part No.	Fig No.	Part No.	Fig No.	Part No.	Fig No.	Part No.	Fig No.	Part No.	Fig No.
11005-2140	01	49049-2075	10	92143-2161	08				
11009-2757	06	49070-2693	07	92144-2054	09				
11010-2526	07	49080-2134	09	92144-2157	09				
11013-2184	07	49088-2500	09	92144-2308	06				
11038-2069	07	49089-2479	03	92144-2390	10				
11049-2006	06	49089-2535	03	92151-2108	07				
11060-2111	06	49089-2598	03	92170-2041	04				
11060-2404	06	49116-2064	08	92170-2080	08				
11060-2435	01	49119-2190	02	92172-0007	07				
11060-2436	07	51001-2299	08	92172-2063	09				
11060-2437	06	51001-2314	08	92190-2174	08				
11065-2072	07	51048-2078	08	92191-2102	08				
13001-2147	02	510A3100	04	92200-2063	03				
13002-2059	02	54012-2525	05	92200-2064	10				
13008-6045	02	54012-2580	05	92200-2074	06				
13033-2052	02	55020-2125	03	92200-2156	03				
13081-2220	10	551A0410	03						
13165-2084	09	56007-2051	12						
13169-2386	09	56039-2890	11						
14002-2331	01	56070-2020	11						
14002-2332	01	56080-2166	11						
14002-2335	01	59066-2724-9B	03						
14002-2347	01	59101-2085	09						
14043-2051	06	59106-2151	09						
14090-2017	06	92002-2163	01						
14091-2053	07	92002-2197	04						
15003-2688	06	92009-1002	07						
16030-2078	06	92009-2115	01						
16055-2051	06	92009-2249	06						
16073-2197	03	92009-2277	06						
16073-2198	04	92009-2336	06						
16073-2202	06	92009-2337	06						
16160-2089	06	92009-2354	06						
16160-2103	06	92009-2358	09						
16185-2024	06	92009-2383	08						
18020-2082	07	92009-2393	07						
21050-2282	04	92009-2394	03						
21050-2301	04	92009-2410	07						
21083-2073	06	92009-2412	09						
21130-2056	04	92009-2420	06						
21169-2051	04	92015-2145	06						
21171-2234	04	92025-2104	02						
233B0516	03	92025-2105	02						
26011-2341	04	92025-2106	02						
26011-2361	04	92026-2125	10						
26011-2376	04	92033-2010	09						
315B0800	04	92033-2061	02						
315B0800	09	92033-2078	06						
32099-2326	05	92043-1302	01						
32099-2358	09	92043-2094	06						
34001-2086	01	92043-2210	10						
410B0800	04	92045-2058	01						
410B0800	09	92049-2108	01						
43028-2054	06	92055-2147	06						
43028-2067	06	92063-2356	06						
43049-2060	06	92070-2103	04						
46075-2128	09	92071-2142	08						
461F0800	04	92071-2157	03						
49019-2111	08	92107-2057	12						
49043-2067	06	92110-2051	12						